

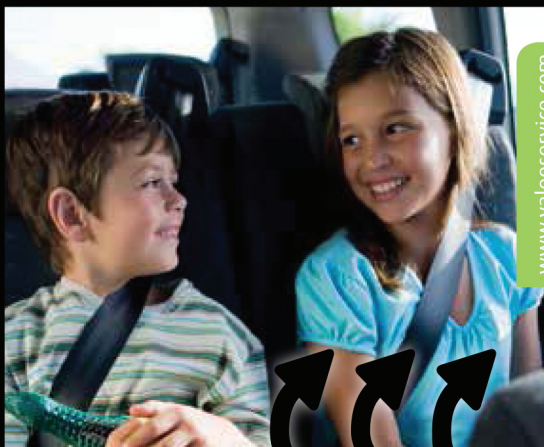

2014

CABIN AIR FILTER
FILTER HABITACLE
FILTRO HABITACULO
FILTRO DE ABITACOLO
INTERIEUR LUCHTFILTER
INNENRAUMLUFTFILTER
FILTR KABINOWY
KABINOVÉ FILTRY
POLLEN SZÜRŐ
FILTERI KABINE
САЛОННЫЙ ФИЛЬТР
KABIN FILTRESI
φίλτρο καμ ινας



www.valeoservice.com



WANT TO
KNOW MORE?*



*en savoir plus

valeo added

*La technologie automobile, naturellement

Automotive technology, naturally

Valeo

314

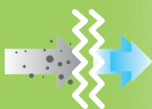

Particle Filter
Particules/pollen

Filtre à Particule
Particules/pollen

Filtro de Partículas
Partículas/polen

Filtro Particellare
Particelle/polline

Filtro de Partículas
Partículas/polen

Partikelfilter
Partikel/Pollen

Deeltjesfilter
Deeltje/pollen

Filtr zwykły
Cząstki/pyłki

Parçacık Filtresi
Parçacık/polen

Угольный фильтр
Частицы/пыльца

168

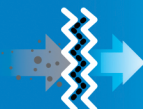

Combined filter with active carbon

Particules/pollen + Harmful gases + Unpleasant odours

Filtre combiné avec charbon actif

Particules/pollen + Gaz nocifs + Odeurs désagréables

Combinado con carbón activo

Partículas/polen + Gases nocivos + Olores desagradables

Combinato con carboni attivi

Particelle/polline + Gas nocivi + Odori sgradevoli

Combinado com carvão ativo

Partículas/polen + Gases nocivos + Odores desagradáveis

Kombifilter mit Aktivkohle

Partikel/Pollen + schädliche Gase + unangenehme Gerüche

Gecombineerd filter met actieve koolstof

Deeltje/pollen + Schadelijke gassen + Onaangename geuren

Filtr przeciwpyłkowy z aktywnym węglem

Cząstki/pyłki + Szkodliwe gazy + Nieprzyjemne zapachy

Aktif karbonlu birleşik filtre

Parçacık/polen + Zararlı gazlar + Kötü kokular

**Комбинированный фильтр
с активированным углем**

Частицы/пыльца + Вредные газы + Неприятные запахи

510

20
NewPart numbers / Références / Referencias / Riferimenti /
Referências / Artikelnummern / Produktnummer /
Referençij / Parça numarasi / Номер артикула

28

**Polyphenol with active carbon**

Particules/pollen + Harmful gases + Unpleasant odours + Allergen neutralization

Polyphénol avec charbon actif

Particules/pollen + Gaz nocifs + Odeurs désagréables + Neutralisation des allergènes

Polifenol con carbón activo

Partículas/polen + Gases nocivos + Olores desagradables + Neutralización de alérgenos

Polifenoli con carboni attivi

Particelle/polline + Gas nocivi + Odori sgradevoli + Neutralizzazione degli allergeni

Polifenol com carvão ativo

Partículas/polen + Gases nocivos + Odores desagradáveis + Neutralização de alergias

Polyphenol mit Aktivkohle

Partikel/Pollen + schädliche Gase + unangenehme Gerüche + Neutralisierung der Allergene

Polyfenolfilter met actieve koolstof

Deeltje/pollen + Schadelijke gassen + Onaangename geuren + Neutraliseert Allergieën

Polifenol z aktywnym węglem

Cząstki/pyłki + Szkodliwe gazy + Nieprzyjemne zapachy + Neutralizacja alergenów

Aktif karbonlu Polifenol

Parçacık/polen + Zararlı gazlar + Kötü kokular + Alerji yapan maddelerin nötrleştirilmesi

Полифенол с активированным углем

Частицы/пыльца + Вредные газы + Неприятные запахи + Нейтрализация действия аллергенов

Multi-protection Air Quality

A unique concept to improve air quality in the cabin.

One of the most complete Cabin Air Filter ranges on the market combined with 2 purifying solutions.



COMFORT

Protects against:



Particles & pollution



Harmful gases



Unpleasant odours



Allergen neutralization

FR Programme multi-protection sur la qualité de l'air.

Un concept unique pour améliorer, la qualité de l'air dans l'habitacle: l'une des gammes les plus complètes de filtres habitacle disponible sur le marché combinant 2 solutions purifiantes.

Protection contre:

- Particules & pollution.
- Gaz nocifs.
- Les odeurs désagréables.
- Neutralisation des allergènes.

DE Multi-protection Air Quality Programm.

Ein einzigartiges Konzept, um die Luftqualität zu verbessern: eines der komplettesten Sortiment im Bereich Innenraumluftfilter auf dem Markt.

Schützt vor:

- Partikel & Abgase.
- Schädliche Gase.
- Unangenehmen Gerüchen.
- Neutralisierung der Allergene.

ES Programa de multiprotección para la Calidad de aire.

Un único concepto para mejorar la calidad del aire en el habitáculo: una de las gamas de filtros de habitáculo más competas del mercado combinada con 2 soluciones de purificación.

Protección contra:

- Partículas & contaminación.
- Gases nocivos.
- Olores desagradable.
- Neutralización de alérgenos.

PT Programa multi-proteção para a qualidade do ar.

Um único conceito para melhorar a qualidade do ar no habitáculo: uma das gamas mais completas de filtros de habitáculo do mercado combinada com 2 soluções de purificação.

Proteção contra:

- Partículas & contaminação.
- Gases nocivos.

IT Programma di multi-protezione della qualità dell'aria.

Un concetto unico per migliorare la qualità dell'aria nell'abitacolo: una delle più complete gamme di Filtri per abitacolo sul mercato che combina due soluzioni di purificazione dell'aria.

Protegge da:

- Particelle & inquinamento.
- Gas nocivi.
- Odori sgradevoli.
- Neutralizzazione allergeni.

NL Programma luchtzuiveringsproducten met meervoudige bescherming.

Een uniek concept dat de luchtkwaliteit in het interieur verbetert: een van de meest complete interieur-filterprogramma's op de markt, gecombineerd met 2 luchtzuiveringstechnologieën.

programme



PROTECT



SUPREME

Beschermt tegen:

- Roetdeeltjes & Uitlaatgassen.
- Schadelijke gassen.
- Onaangename geuren.
- Hyposensibilisati.

дополненный двумя
позициями очищающих
жидкостей.

Защищает от:

- Микрочастицы & Загрязнения.
- Вредоносные газы.
- Неприятных запахов.
- Нейтрализация аллергенов.

kabin hava filtre serisi ve
üstün özellikli iki arındırıcı
sunumu.

Geniş koruma:

- Parçacıklar & Kirlilik.
- Zararlı gazlar.
- Kötü kokular.
- Alerji yapan maddelerin nötrleştirilmesi.

PL Program Valeo - Jakość Powietrza.

Unikalna koncepcja poprawy jakości powietrza w kabinie: jedna z najbardziej kompletnych gam filtrów kabinowych na rynku w połączeniu z 2 środkami czyszczącymi.

Chroni przed:

- Cząsteczki & Zanieczyszczenia.
- Szkodliwe gazy.
- Nieprzyjemnymi zapachami.
- Neutralizacja alergenów.

CS Ochrana kvality vzduchu v kabině.

Unikátní koncept ke zlepšení kvality ovzduší v kabině: nejkompexnější nabídka pylových filtrů na trhu a dvě formy čistění.

Pro:

- Částice & Spaliny.
- Škodlivé plyny.
- Nepříjemnými zápachy.
- Neutralizace alergenů.

EL Πρόγραμμα πολύ-προστασίας Ποιότητας Αέρα.

Ενα μοναδικό σχέδιο βελτίωσης της ποιότητας αέρα εντός της καμπίνας: μία από τις πιο ολοκληρωμένες σειρές Φίλτρων Καμπίνας στην αγορά, που συνδυάζει 2 λύσεις καθαρισμού.

προστατεύει ενάντια:

- Σωματίδια & Ρύπανση.
- Επιβλαβή αέρια.
- Δυσάρεστες οσμές.
- Εξουδετέρωση των αλλεργιογόνων.

RU Программа Мульти-защиты Качества воздуха.

Уникальная концепция для улучшения качества воздуха в салоне: широкий ассортимент Фильтров воздуха салона,

TR Çoklu koruma içeren Hava Kalitesi programı.

Araç içi hava kalitesini mükemmelleştirmek için eşsiz çözümler: Eksiksiz

Multi-protection Air Quality

Allergen neutralization.

To protect against entrance of the inhalation allergen into the cabin.



DE Multi-protection Air Quality Programm.

Neutralisierung der Allergene. Schützt vor Gelangen des Allergens in den Fahrzeuginnenraum.

ClimFilter™ Supreme

- Eine einzigartige patentierte Lösung von Valeo, welche die Vorteile von Aktivkohle und Polyphenol-Beschichtung (**dient der Neutralisation von Allergene**) verbindet.
- 9 neue Top-Renner für 2014.
- Die gesamte ClimFilter™ Supreme Produktpalette deckt: 90 Millionen Fahrzeuge in Europa ab.

ES Programa de multiprotección para la Calidad de aire.

Neutralización de alérgenos. Para proteger contra entrada del alérgeno al interior del habitáculo.

ClimFilter™ Supreme

- Una solución única patentada por Valeo que combina los beneficios del carbón activo y una capa de polifenol (**neutralización de alérgenos**).
- 9 referencias de alta rotación para 2014.
- Cobertura de la gama ClimFilter™ Supreme: 90 millones de vehículos en Europa.

PT Programa multi-proteção para a qualidade do ar.

Neutralização de alergias. Para proteger contra entrada de alérgeno no interior do habitáculo.

ClimFilter™ Supreme

- Uma solução única patenteada por Valeo que combina os benefícios do carvão activo e uma capa de polifenol (**neutralização de alérgenos**).
- 9 referências de alta rotação para 2014.
- Cobertura da gama ClimFilter™ Supreme: 90 milhões de veículos na Europa.

FR Programme multi-protection sur la qualité de l'air.

Neutralisation des allergènes. Pour protéger contre l'entrée des pneumallergènes dans l'habitacle.

ClimFilter™ Supreme

- Une solution unique brevetée combinant les avantages du charbon actif et du polyphenol (**neutralisation des allergènes**).
- 9 nouvelles références à forte rotation pour 2014.
- Couverture de la gamme ClimFilter™ Supreme: 90 millions de véhicules en Europe.

programme

ClimFilter™ Supreme

A unique Valeo patented solution which combines the advantages of active carbon and polyphenol coating (**allergen neutralization**).

9 new fast movers for 2014

Total ClimFilter™ Supreme range covering:
90 million vehicles in Europe.



IT Programma di multi-protezione della qualità dell'aria.

Neutralizzazione degli allergeni. Protegge da ingresso dell'allergene da inalazione nell'abitacolo.

ClimFilter™ Supreme

- Una soluzione unica e brevettata Valeo che combina i vantaggi del carbone attivo e i polifenoli (**neutralizzazione degli allergeni**).
- 9 nuovi riferimenti per il 2014.
- Gamma completa ClimFilter™ che copre: 90 milioni di veicoli in Europa.

NL Programma luchtzuiverings-producten met meervoudige bescherming.

Neutraliseert Allergieën. Beschermt tegen buitenlucht met allergenen stroomt het interieur binnenw.

ClimFilter™ Supreme

- Een unieke, door Valeo gepatenteerde oplossing die de voordelen van actieve koolstof en een polyphenol coating (**neutralisatie van allergenen**) combineert.
- 9 nieuwe snellopers voor 2014.
- Het volledige ClimFilter™ Supreme programma dekt 90 miljoen voertuigen in Europa.

PL Program Valeo - Jakość Powietrza.

Neutralizacja alergenów. Chroni przed wnikanie wziewnych alergenów do kabiny pojazdu.

ClimFilter™ Supreme

- Unikalne opatentowane rozwiązanie Valeo, które łączy zalety stosowania aktywnego węgla i polifenolu (**neutralizacja alergenów**).
- 9 nowych szybko rotujących refs. w 2014r.
- Całkowite pokrycie rynku przez ClimFilter™ Supreme: 90 milionów pojazdów w Europie.

RU Программа Мульти-защиты Качества воздуха. Нейтрализация действия аллергенов. Защищает от Попадание аллергенов в салон.

ClimFilter™ Supreme

- Уникальное запатентованное решение Valeo сочетает преимущества активированного угля и полифенольного покрытия (**нейтрализация аллергенов**).
- 9 востребованных новинок в 2014 году.
- Весь ассортимент ClimFilter™ Supreme покрывает 90 миллионов транспортных средств в Европе.

CS Ochrana kvality vzduchu v kabině.

Neutralizace alergenů
Ochranu proti vniknutí alergenů do kabiny.

ClimFilter™ Supreme

- Unikátní Valeo patentované řešení, které kombinuje výhody aktivního uhlí s polyfenolovou vrstvou (**neutralizace alergenů**).

TR Çoklu koruma içeren Hava Kalitesi programı.

Alerji yapan maddelerin nütürleştirilmesi. Geniş koruma Solunabilen alerjenlerin kabine girişi.

ClimFilter™ Supreme

- Valeo patentli alerji yapan maddelerin nütürleştirilmesini sağlayan aktif karbon ve polifenol korumalı eşsiz çözüm.
- 2014'te 9 yeni hızlı referans.
- ClimFilter™ Supreme ürün serisi Avrupa'da 90 milyon aracı kapsamaktadır.

EL Πρόγραμμα πολύ-προστασίας Ποιότητας Αέρα.

Εξουδετέρωση αλλεργιογόνων.

Προστατεύει ενάντια είσοδος του αλλεργιογόνου από την καμπίνα.

ClimFilter™ Supreme

- Μια μοναδική πατενταρισμένη λύση της Valeo που συνδυάζει τα πλεονεκτήματα του ενεργού άνθρακα και του στρώματος πολυφαινόλης (**εξουδετέρωση αλλεργιογόνων**).
- 9 νέοι κινησιμικοί κωδικοί για το 2014.
- Η πλήρης σειρά ClimFilter™ Supreme καλύπτει: 90 εκατομμύρια οχήματα στην Ευρώπη.

Multi-protection Air Quality

2 purifying solutions.

To protect against bacteria & unpleasant odours.



To clean the A/C circuit



To purify the cabin



FR Programme multi-protection sur la qualité de l'air.

2 solutions purifiantes.

Pour protéger contre les bactéries et les odeurs désagréables:

- Pour nettoyer le circuit de climatisation.
- Pour purifier l'habitacle.

ES Programa de multiprotección para la Calidad de aire.

2 soluciones de purificación.

Para proteger contra bacterias y malos olores:

- Para limpiar el circuito de climatización.
- Para purificar el habitáculo.

IT Programma di multi-protezione della qualità dell'aria.

Due soluzioni di purificazione dell'aria.

- Sgradevoli e sgradevoli odori:
- Per pulire il circuito A/C.
 - Per purificare l'abitacolo.

DE Multi-protection Air Quality Programm.

2 Reinigungslösungen.

Schützt vor Bakterien & unangenehmen Gerüchen:

- Zur Reinigung des Klimakreislaufs.
- Zur Reinigung des Innenraums.

PT Programa multi-proteção para a qualidade do ar.

2 soluções de purificação.

Para proteger contra bactérias e maus odores:

- Para limpar o circuito de climatização.
- Para purificar o habitáculo.

NL Programma luchtzuiveringsproducten met meervoudige bescherming.

2 luchtzuiveringstechnologieën.

- Beschermt tegen bacteriën en onaangename geuren:
- Reinigt het aircocircuit.
 - Zuivert de interieurlucht.

programme



Valeo
ref. 698984



Valeo
ref. 698899

PL Program Valeo - Jakość Powietrza.

2 środkami czyszczącymi.
W celu ochrony przed bakteriami i nieprzyjemnymi zapachami:

- Do czyszczenia układu klimatyzacji.
- Do czyszczenia zanieczyszczeń wewnątrz kabiny.

RU Программа Мульти-защиты Качества воздуха.

И двумя позициями очищающих жидкостей.
Бактерий и неприятного запаха:

- Очищает контур системы кондиционера.
- Очищает воздух в салоне.

CS Ochrana kvality vzduchu v kabině.

Dvě formy čištění.
Ochranu proti bakteriím & nepřijemnému zápachu:

- Čištění obvodu klimatizace.
- Čištění kabiny vozidla.

TR Çözümlü koruma içeren Hava Kalitesi programı.

İki arındırıcı sunumu.
Bakteri ve kötü kokulara karşı güçlü etki:

- Klima çevriminde üstün temizlik.
- Arındırılmış kabin içi atmosfer.

EL Πρόγραμμα πολύ-προστασίας Ποιότητας Αέρα.

2 λύσεις καθαρισμού.
Προστατεύει ενάντια στα βακτήρια & στις δυσάρεστες οσμές:

- Καθαρίζει το κύκλωμα κλιματισμού.
- Καθαρίζει την καμπίνα.

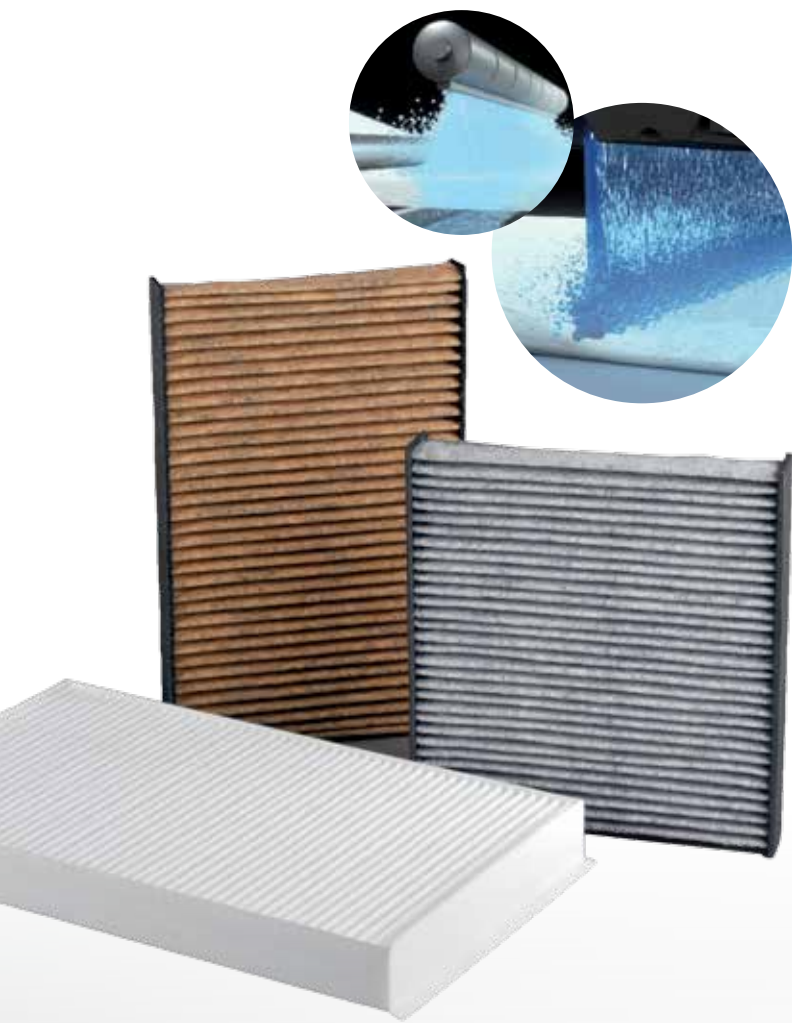

Valeo know-how

- manufacturing high quality media
- the exclusive environmental friendly production process - water jet bonding (patented Valeo) - the media layers are joint with high pressure water
- high filtration precision without reducing the air flow
- recognized by car manufacturers (OE supplier)

FR Le savoir-faire de Valeo

- Un média de haute qualité fabriqué dans notre usine
- Un procédé Valeo exclusif et breveté, respectueux de l'environnement : «le collage par jet d'eau» (les couches de média sont collées grâce à de l'eau sous haute pression)
- Filtration haute précision sans réduction du flux d'air
- Qualité Premium reconnue par les constructeurs

DE Valeo Know-how

- hochqualitatives Filtermaterial aus eigener Herstellung
- exklusiver, von Valeo patentierter und umweltfreundlicher Herstellungsprozess: «Wasserstrahlverbindung» (die Filterschichten werden mit einem Hochdruck-Wasserstrahl miteinander verbunden)
- hohe Filterpräzision ohne Verringerung der Luftdurchlässigkeit
- Von Fahrzeugherstellern anerkannte Premium Qualität

SP El saber hacer de Valeo

- Medio filtrante de alta calidad y de producción propia
- Exclusivo proceso de producción respetuoso con el medio ambiente: «entrelazado por chorro de agua» (las capas de medio filtrante son unidas mediante agua a alta presión)
- Alta precisión de filtrado sin reducir el flujo de aire
- Calidad Premium reconocida por los fabricantes de automóviles

PT O know-how da Valeo

- Meio filtrante de alta qualidade e de produção própria
- Processo exclusivo de produção respeitando o meio ambiente: «ligação jato de água» (as capas de meio filtrante são unidas por meio de água a alta pressão)
- Alta precisão de filtrado sem reduzir o fluxo de ar
- Prémio de Qualidade reconhecido por fabricantes de Automóveis

IT Esperienza Valeo

- Produzione interna di alta qualità della media
- Processo esclusivo brevettato ed ecosostenibile Valeo: «getto d'acqua di legame» (gli strati media sono uniti grazie a getti d'acqua ad alta pressione)
- Elevata precisione di filtrazione senza ridurre il flusso dell'aria
- Qualità superiore riconosciuta dai produttori di autoveicoli

NL Valeo knowhow

- hoogwaardig filtermateriaal uit eigen productie
- exclusief milieuvriendelijk productieproces (Valeo-patent); hecht de materiaallagen aaneen met een hogedrukwaterstraal
- hoge filterprecisie; hindert de luchtstroom niet
- Hoogwaardige kwaliteit, erkend door autofabrikanten

PL Specjalizacja Valeo

- Wysokiej jakości media filtracyjne własnej produkcji
- Ekskluzywny opatentowany przez Valeo proces przyjazny dla środowiska: «klejenie strumieniem wody» (warstwy medium filtracyjnego są łączone wodą pod wysokim ciśnieniem)
- Wysoka dokładność filtracji bez zmniejszenia przepływu powietrza
- Premium Jakość doceniana przez producentów samochodów

RU Ной-хау Валео

- Высококачественное производство
- Эксклюзивный запатентованный технологический процесс с заботой об окружающей среде: «действие напора воды» (слои фильтра сливаются под действием сильного напора воды)
- Высокий уровень фильтрации без сокращения воздушного потока
- Премиум качество оценено автопроизводителями

CZ Valeo know - how

- Vlastní výroba vysoce kvalitní filtrační látky
- Spojování vodním paprskem «water jet bonding»: ekologický proces patentovaný společností Valeo. Vysokotlaký vodní proud spojí pevně k sobě jednotlivá vlákna
- Vysoká přesnost filtrace bez snížení průtoku vzduchu
- Prémiová kvalita uznávaná výrobci automobilů

RO Experiența Valeo

- Mediu de filtrare de înaltă calitate produsă în uzina noastră.
- Un procedeu exclusiv Valeo, brevetat și ecologic: «colaj cu jet de apă» (straturile de media sunt lipite cu ajutorul unui jet de apă sub presiune mare)
- Precizie înaltă de filtrare fără reducerea fluxului de aer
- Calitate Premium recunoscută de producătorii de mașini

TU Valeo bilgi birikimi

- Yüksek kalite filtre elemanı
- Özel Valeo patentli çevre dostu üretim süreci: «su jeti teknolojisi» (iltre eleman katmanlarının yüksek basınçlı su ile birleştirilmesi)
- Hava akış hızını düşürmeden yüksek filtreleme
- Araç üreticileri tarafından tanınan yüksek kalite

GR Τεχνογνωσία Valeo

- Κατασκευή μέσων υψηλής ποιότητας
- αποκλειστική πατενταρισμένη διαδικασία, φιλική προς το περιβάλλον: «συναρμολόγηση με νερό» (τα στρώματα των φιλτραντικών μέσων συνδέονται με νερό υψηλής πίεσης)
- υψηλή ακρίβεια φιλτραρίσματος χωρίς μείωση της ροής του αέρα
- Ανώτερη Ποιότητα αναγνωρισμένη από τους κατασκευαστές αυτοκινήτων





GENERAL SYMBOLS & ABBREVIATIONS

Vehicle
Véhicule
Fahrzeug
Vehículo
Viatura
Veicolo
Voertuig
Pojazd
Автомобиль
Vozidlo
Vozilo
Gépjármű
Vehicul
Προvezονο σροδστυο
Αραç
Οχημα



Date of vehicle
Période de fabrication
Baujahr
Periodo de fabricaciòn
Periodo de fabricaçao
Periodo di fabbricazione
Bouwjaar



Data produkci
Год производства
Datum výroby
Datum proizvodnje
Gyártási év
Perioadă de fabricare
Дата на производство
Αραç üretim tarihi
Ημερομηνία κατασκευής

Until chasis N°
Jusqu'au Châssis N°
Bis Fahrgestellnummer
-> Hasta N° de chasis
Até n° de chasis
Fino al telaio N°
Tot chassisnummer



► N°

Do numeru nadwozia
До шасси №
Do čísla karoserie
Do broja karoserije
Alvázsámig
Până la Șasiul Nr.
До номер на рама
... șasi numarasina kadar
μέχρι σασί ΝΓ

From the Chasis N°
A partir du Châssis N°
Ab Fahrgestellnummer
A partir del N° de chasis ->
A partir de n° de chasis
A partire dal telaio N°
Vanaf chassisnummer



N° ►

Od numeru nadwozia
От шасси №
Od čísla karoserie
Od broja karoserije
Alvázsámtól
Începând cu Șasiul Nr.
От номер на рама
... șasi numarasindan sonra
Αότι σασί ΝΓ

Images
Images
Abbildungen
Foto/esquemas
Foto/Esquema
Immagini



Afb.
Ilustracja
Рисунки
Zobrazení
Slike
Képek
Imagini
Снимки
Resim
ικόνες

New
Nouveau
Neu
Nuevo
Novo
Nuovo
Nieuw
Nowy
Новый
Nové
Nou
Nouă
Нов
Yeni
Néo

Soon available part numbers
Références disponibles prochainement
Artikel in Kürze lieferbar
Referencias disponibles próximamente
Referências disponiveis próximamente
Riferimenti disponibili nei prossimi mesi
Binnenkort leverbaar
Produkt wkrótce dostępny
Позиции скоро будут доступны
Produkt brzy dostupny
Uskoro u prodaji
Referințele disponibile în curând
Очаквайте скоро
Yakinda sunulacak
Κωδικούς σύντομα διαθέσιμα

AC

Without
Sans
Ohne
Sin
Sim
Senza
Zonder
Bez
без
Bez
Nincs
Fără
Без
Ayrı olarak
χωρίς

With
Avec
Mit
Con
Com
Con
Met
Z
c
S
sa
Van
Cu
C
Birlikte
με

Manual air conditioning
Climatisation manuelle
Manuelle Klimaanlage
Climatización manual
Climatizaçao manual
AC manuale
Manuele Klimaatregeling
Klimatyzacja manualna
Кондиционер ручного управления
Mechanická klimatizace
Ručni klima uređaj
Manuális klíma
Climatizare manuală
Климатик
Manuel klima
Χειροκίνητος κλιματισμός

M+

A+

Auto air conditioning
Climatisation automatique
Klimaautomatik
Climatización automática
Climatização automática
AC automatica
Elektronische Klimaatregeling
Klimatyzacja automatyczna
Климат контроль
Automatická klimatizace
Automatski klima uređaj
Automata klíma
Climatizare automată
Климатроник
Otomatik klima
Αυτόματος κλιματισμός

DRIVE SIDE

Right Hand Drive
Conduite à droite
Rechtslenker
Conducción a Derechas
Condução a direita
Guida a destra
Rechts gestuurd
Kierownica z prawej strony
Автомобили с рулем справа
Volant v pravo
volan desno
Jobbkormányos jármű
Conducere pe dreapta
С дясна кормилна уредба
Sağdan direksiyon
Δεξιότιμονο



Left Hand Drive
Conduite à gauche
Linkslenker
Circulación a Izquierdas
Circulação a esquerda
Guida a sinistra
Links gestuurd
Kierownica z lewej strony
Автомобили с рулем слева
Volant v levo
volan lijevo
Balkormányos jármű
Conducere pe stânga
С лява кормилна уредба
Soldan direksiyon
αριστεροτιμονο

**TECHNOLOGY**

Particle Filter
Filtre à particules
Partikelfilter
Filtro de partículas
Filtro de partículas
filtro particellare
Deeltjesfilter
Filtr przeciwpyłkowy
Угольный фильтр
Ćásticový filtr
Filter čestica
Részecske szűrő
Filtro de particule
Поленов филтър
Paçsacık filtresi
φίλτρα σωματιδίων

Combined with active carbon
Filtre combiné
Kombifilter mit Aktivkohle
Combinado con carbón activo
Combinado com carvão activo
Combinato con carboni attivi
Gecombineerd filter met actieve koolstof
Filtr przeciwpyłkowy z aktywnym węglem
Комбинированный фильтр с активированным углем
Kombinovaný filtr s aktivním uhlím
Kombinirani filter s aktivnim ugljenom
Aktiv szénnel kombinált
Filtro combinat cu carbon activ
Филтър с активен въглен



PA



CA



PCA

100%

ACT.CARBON

Ultrafine

(-)

Prefilter

Aktif karbonlu birleşik filtre
φίλτρα ενεργού άνθρακα
Polyphenol with active carbon
Polyphénol avec charbon actif
Polyphenol mit Aktivkohle
Polifenol con carbón activo
Polifenol com carvão activo
Polifenoli con carboni attivi
Polyfenolfilter met actieve koolstof
Polifenol z aktywnym węglem
Полифенол с активированным углем
Polyfenol s aktivním uhlím
Polifenol s aktivnim ugljenom
Polyphenol aktiv szénnel
Polifenol cu carbon activ
Aktif karbonlu Polifenol
Πολυφενόλη με ενεργό άνθρακα

APPLICATION DETAILS

100% Activated Carbon Filter
100% Filtre à Charbon Actif
100% Aktivkohlefilter
100% Filtro de Carbón Activo
100% filtro de carvão activo
100% Filtro a carbone attivo
100% Aktieve koolstoffilter
Filtr z aktywnym węglem
Филтър со 100% активированным углем
Filtr se 100% aktivním uhlíkem
Filter sa 100% aktivnim ugljikom
100% aktiv szenes szűrő
100% Filtru cu carbune activ
Филтър 100% активен въглен
100% Aktif karbon Filtre
Φίλτρο 100% ενεργού άνθρακα

Ultrafine
ultrafin
Ultrafein
ultrafina
ultrafina
ultrafine
ultrafijn
ultrafine
задержки сверхмелких частиц
Ultrajemná
Ultra fino
ultrafinom
ultrafin
Yüksek Filtreleme
υπερβολικά λεπτό

Except
Sauf
Ohne
Sin
Sim
Ad eccezione d
Zonder
Z wyjątkiem
Кроме
S výjimkou
Osím
Kivéve
Fără
С изключение
Haris
Εκτός από

Prefilter
Pré-filtre
Vorfilter
Pre-filtro
Pré-Filtro
Pre-filtro
Voorfilter
Filtr wstępny
предфилтър
S předfiltrováním
Előszűrővel
Prefiltro
Предфилтър
Ön filtre
Προφίλτρο

Without
plastic
frame

Without plastic frame
Sans cadre plastique
Ohne Kunststoffrahmen
Sin marco de plástico
Sem marca de plástico
Senza cornice in plastica
Zonder plastic frame
Bez obudowy plastikowej
без пластикового элемента
Bez plastového rámce
Műanyag keret nélkü
Fara cadru de plastic
без пластмасова рамка
Plastik çerçevesiz
Χωρίς πλαίσιο

KIT

Kit
kit
Kit
Kit
Kit
kit
Set
Komplet
комплект
Sada
kit
Készlet
Kit
Комплект
Kit
Σετ

FITTING TIME

Quick



Quick ≤ 15 min.
Rapide ≤ 15 min.
schnell ≤ 15 Min.
Rápido ≤ 15 min.
Rápido ≤ 15 min.
Veloce ≤ 15 min.
Snel ≤ 15 min.
Krótki ≤ 15 min.
Быстрое ≤ 15 мин.
Rychlá ≤ 15 min.
brzo ≤ 15 min.
Gyors ≤ 15 perc.
Rapid ≤ 15 min.
15 dakikadan çabuk
Μικρός ≤ 15 λεπτά

Medium



Medium 16-25 min.
Moyen 16-25 min.
mittel 16-25 Min.
Medio 16-25 min.
Medio 16-25 min.
Medio 16-25 min.
Gemiddeld 16-25 min.
Sredni 16-25 min.
Среднее 16-25 мин.
Střední 16 – 25 min.
srednje 16-25 min.
Közepes 16-25 perc.
Mediu 16-25 min.
16-25 dakika arası
Μεσαίος 16-25 λεπτά

Long



Long ≥ 26 min.
Long ≥ 26 min.
lange ≥ 26 Min.
Largo ≥ 26 min.
Longo ≥ 26 min.
Lungo ≥ 26 min.
Langzaam ≥ 26 min.
Długi ≥ 26 min.
Долгое ≥ 26 мин.
Diouhá ≥ 26 min.
dugo ≥ 26 min.
Hosszú ≥ 26 perc
Lung ≥ 26 min.
26 dakikadan fazla
Μεγάλος ≥ 26 λεπτά

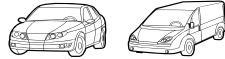
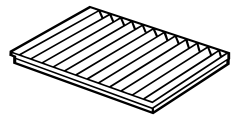

NEW

New Nouveau **Neu** Nuevo **Novo** Nuovo **Nieuw**
Nowy **Новый** Nové **Nou** Nouă **Нов** Yeni **Νέο** 12



➔ **Valeo**

13



47



➔ **Valeo**

51

Valeo

➔ **OE**

129



➔ **Valeo**

155



➔ **Valeo**

163



NEW

New Nouveau **Neu** Nuevo **Novo** Nuovo **Nieuw**
Nowy **Новый** Nové **Nou** Nouă **Нов** Yeni **Νέο** 196



➔ **Valeo**

197

clim PUR™



clim SPRAY™



ROLL MEDIA



203



➔ **Valeo**

207



VT01

VT02

VT03

VT04

VT05

VT06

219

Valeo

➔ **OE**

227



➔ **Valeo**

234



➔ **Valeo**

236

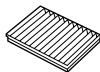

EN

Function

The cabin air filter prevents harmful pollutants from the surrounding air entering the cockpit via the air-conditioning and ventilation shafts.

There are 3 different technologies of cabin air filters:

- particle filters for solid pollutants: dust, tar, pollen...
- combined filters for solid pollutants + other pollution: exhaust fumes, bad odours...
- polyphenol filters for allergen (pollen) neutralization, solid pollutants, harmful gases, bad odours

Replacement

Essential for safety and comfort as well as the efficiency of the air-conditioning system, cabin air filters must be replaced regularly - every year or every 15.000 km (10000 miles).

The Cabin air filter can be located near the air entry or the evaporator.

Typical problems with cabin air filters

- Lack of air blown into the cabin (less air-conditioning, slower defogging...)
- Allergic reactions (sneezing, irritations...)
- Poor air quality in the cabin (bad odours, pollution...)

New packaging - CARTON

Valeo introduces the new carton packaging for its Cabin Air Filter range:

- ClimFilter™ "Comfort" for particle filters.
- ClimFilter™ "Protect" for combined filters.
- Current plastic bag packaging (delivered until the stock lasts) is replaced by new carton packaging.
- Codification of cabin air filter part numbers remains unchanged (698xxx, 715xxx), only packaging type changes.

Repair recommendations

- Choose the right cabin air filter according to the vehicle.
- For the highest driver & passengers protection the polyphenol filter is recommended.
- Specific fitting instructions are included with all Valeo cabin air filters to promote efficient replacement.
- Valeo's recommendation for healthier air in the vehicle is to use an A/C cleaning and purifying treatment with every cabin air filter change (Climpur Valeo).

FR

Fonction

Le filtre d'habitacle empêche les polluants nocifs de l'air extérieur d'entrer dans l'habitacle du véhicule par les conduits de ventilation et de climatisation.

Il existe 3 technologies de filtres d'habitacle:

- les filtres à particule contre les polluants de type solide (poussières, suies, pollens...)
- les filtres combinés qui cumulent la fonction anti-particule à une fonction anti-pollution en protégeant des gaz d'échappement nocifs et des odeurs ambiantes désagréables...
- les filtres polyphénol pour neutralisation des allergènes, polluants solides, gaz nocifs, mauvaises odeurs

Remplacement

Indispensable pour la sécurité et le confort ainsi que pour le bon fonctionnement de la climatisation, le filtre d'habitacle doit être remplacé tous les ans ou tous les 15.000 km minimum.

Il est situé soit près de la grille d'aération, soit près de l'évaporateur.

Problèmes les plus fréquents liés au filtre d'habitacle:

- Manque d'air pulsé dans l'habitacle (moins de froid, mauvais désembuage...)
- Réactions allergiques dans l'habitacle (éternuements, irritations...)
- Mauvaise qualité de l'air dans l'habitacle (odeurs, pollution...)

Nouveau packaging CARTON

Valeo présente le nouveau packaging de la gamme filtre d'habitacle :

- ClimFilter™ "Comfort" pour filtres à particules.
- ClimFilter™ "Protect" pour filtres combinés.
- Les packaging actuels en plastique (livré comme ceci jusqu'à épuisement des stocks) sont remplacés par de nouveaux packaging en carton.
- La codification des références de filtre d'habitacle reste inchangée (698xxx; 715xxx), seul le packaging évolue.

Recommandations Valeo pour la Réparation

- Choisissez le filtre habitacle pour votre véhicule.
- Le filtre polyphénol est recommandé pour une protection maximale des conducteurs et passagers.
- Optimisez votre prestation en vous référant aux notices de montage livrées avec les filtres d'habitacle Valeo.
- Pour une qualité de l'air optimale, pensez à utiliser un nettoyant purifiant du circuit de climatisation à chaque remplacement du filtre d'habitacle (Climpur Valeo).

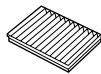
DE
Funktion

Der Innenraumluftfilter verhindert das Eindringen von Schadstoffen aus der Umgebungsluft in den Fahrzeuginnenraum durch die Lüftungs- und Klimatisierungsleitungen.

Drei verschiedene Innenraumluftfilter-Technologien stehen zur Verfügung:

- Partikelfilter für Schadstoffe in fester Form: Staub, Ruß, Pollen
- Kombifilter für feste und sonstige Schadstoffe (Abgase, unangenehme Gerüche usw.)
- Filter mit Polyphenol zur Neutralisierung von Allergenen, festen Schadstoffen, schädlichen Gasen, schlechten Gerüchen

Austausch

Innenraumluftfilter leisten einen unverzichtbaren Beitrag zur Sicherheit, zum Komfort und zur Leistungsfähigkeit des Klimasystems und müssen folglich regelmäßig ausgewechselt werden (einmal im Jahr oder alle 15.000 km).

Der Innenraumfilter befindet sich in der Nähe des Lufteintritts oder des Verdampfers

Häufige Probleme mit Innenraumluftfiltern:

- Es wird zu wenig Luft in den Innenraum geblasen (unzureichende Leistung der Klimaanlage, die Scheiben bleiben beschlagen usw.)
- Allergiereaktionen der Fahrzeuginsassen (Niesen, Reizungen usw.)
- Schlechte Luftqualität im Innenraum (unangenehme Gerüche, Schadstoffe usw.)

Neue Verpackung - KARTON

Valeo stellt die neue Kartonverpackung für sein Sortiment an Innenraumluftfiltern vor:

- ClimFilter™ "Comfort" für Pollenfilter.
- ClimFilter™ "Protect" für Kombifilter.
- Die derzeitige verwendete Verpackung im Plastikbeutel (verwendet solange der Vorrat reicht) wird durch die neue Kartonverpackung ersetzt.
- Die Ver Nummerung der Artikel bleibt unverändert (698xxx, 715xxx), nur die Verpackungsart ändert sich.

Reparaturempfehlungen

Wählen Sie den passenden Innenraumluftfilter für Ihr Fahrzeug aus.

Für den höchsten Schutz für Fahrer und Insassen wird der Polyphenolfilter empfohlen.

Alle Innenraumluftfilter von Valeo werden mit präzisen Montageanweisungen geliefert, die den fachgerechten Einbau garantieren. Valeo empfiehlt bei jedem Wechsel des Innenraumluftfilters eine Desinfektion des Lüftungskreislaufs mit Climpur.

ES
Función

El filtro de habitáculo impide que los contaminantes nocivos del exterior entren en el habitáculo del vehículo por los conductos de ventilación y climatización.

Existen 3 tecnologías de filtros de habitáculo:

- los filtros de partículas para los contaminantes sólidos (polvo, alquitrán, polen, etc.)
- los filtros combinados para las partículas sólidas y otros contaminantes (gases de escape, olores desagradables, etc.)
- filtros de polifenol para la neutralización de alérgenos, contaminantes sólidos, gases nocivos, malos olores

Sustitución

Indispensable para la seguridad y el confort, así como para el buen funcionamiento de la climatización, el filtro de habitáculo debe sustituirse regularmente, cada año o cada 15.000 km.

Este filtro puede colocarse junto a la entrada de aire o al evaporador.

Problemas más frecuentes relativos al filtro de habitáculo:

- Falta de aire impulsado en el habitáculo (menos frío, antivaho más lento, etc.)
- Reacciones alérgicas (estornudos, irritaciones, etc.)
- Mala calidad del aire en el habitáculo (malos olores, contaminación, etc.)

Nuevo embalaje - CARTÓN

Valeo presenta el nuevo embalaje de cartón para su gama de Filtros de Habitáculo:

- ClimFilter™ "Comfort" para filtros de partículas.
- ClimFilter™ "Protect" para filtros combinados.
- El actual embalaje en bolsa de plástico es sustituido por el nuevo embalaje cartón.
- La codificación de referencias de los filtros de habitáculo se mantiene inalterada (698xxx, 715xxx). Los cambios afectarán únicamente al tipo de embalaje.

Recomendaciones para la reparación

- Elija el filtro de habitáculo adecuado para su vehículo
- El filtro de polifenol es aconsejable para una máxima protección de conductor y ocupantes
- Los filtros de habitáculo Valeo se entregan con instrucciones de instalación para facilitar una sustitución eficaz.
- Para una calidad óptima del aire, Valeo recomienda aplicar un tratamiento de limpieza y/o purificación del circuito de climatización cada vez que se reemplace el filtro de habitáculo (Climpur Valeo).

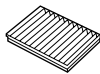

PT

Função

O filtro de habitáculo previne que os poluentes nocivos do ar entrem no habitáculo através do ar-condicionado e condutas de ventilação.

Há 3 tecnologias diferentes de filtros de habitáculo:

- filtros de partículas para poluentes sólidos: pó, polen, ...
- filtros combinados para poluentes sólidos + outra poluição: gases de escape, maus cheiros...
- filtros de polifenol para a neutralização de alergias, contaminantes sólidos, gases nocivos, maus odores

Substituição

Essencial pela segurança e conforto bem como para a eficiência do ar-condicionado, os filtros de habitáculo devem ser substituídos regularmente - todos os anos ou a cada 15.000 km.

O filtro de habitáculo encontra-se perto da entrada do ar ou do evaporador.

Problemas comuns com os filtros de habitáculo:

- Falta de fluxo de ar para o habitáculo (menos ar condicionado, desembaciamento mais lento...)
- Reações alérgicas (espirros, irritações...)
- Fraca qualidade do ar no habitáculo (maus cheiros, poluição...)

Nova embalagem - CARTÃO

Valeo apresenta a nova embalagem de cartão para a sua gama de Filtros de Habitáculo:

- ClimFilter™ "Comfort" para filtros de partículas.
- ClimFilter™ "Protect" para filtros combinados.
- A actual embalagem em bolsa de plástico é substituída por uma nova embalagem de cartão.
- A codificação de referências dos filtros de habitáculo mantém-se inalterada (698xxx, 715xxx). As alterações afectam unicamente o tipo de embalagem.

Recomendações de reparação

- Escolha o filtro de habitáculo adequado para o seu veículo
- O filtro de polifenol é aconselhável para uma máxima protecção do condutor e ocupantes
- Instruções de montagem específicas estão incluídas em todos os filtros de habitáculo Valeo promovendo uma substituição eficiente.
- A recomendação da Valeo para um ar mais saudável dentro do habitáculo, é a utilização de produtos de purificação e limpeza Valeo quando substitui um filtro de habitáculo (Climpur da Valeo).

IT

Funzione

Il filtro abitacolo previene che gli inquinanti nocivi dell'aria esterna entrino nell'abitacolo del veicolo attraverso i condotti del sistema di aerazione e di climatizzazione. Esistono 3 diverse tecnologie di filtri abitacolo:

- i filtri particellari, contro gli inquinanti di tipo solido: polveri, catrame, polline...
- i filtri a carboni attivi, che uniscono la funzione antiparticellare ad una funzione antinquinante per trattenere i gas di scarico, gli odori sgradevoli...
- i filtri ai polifenoli per la neutralizzazione degli allergeni (polline), inquinanti solidi, gas nocivi, cattivi odori

Sostituzione

Indispensabile per la sicurezza e il comfort, oltre che per il corretto funzionamento dell'impianto di aria condizionata, il filtro abitacolo deve essere sostituito una volta l'anno oppure almeno ogni 15.000 km.

Il filtro abitacolo è situato vicino alla presa aria o all'evaporatore.

Problemi più frequenti relativi al filtro abitacolo:

- Aria insufficiente all'interno dell'abitacolo (scarso raffreddamento, disappannamento lento...)
- Reazioni allergiche, riniti, irritazioni...
- Cattiva qualità dell'aria nell'abitacolo (odori sgradevoli, inquinamento...)

Nuovo packaging - CARTONE

Valeo presenta il nuovo packaging in cartone per la gamma dei Filtri Abitacolo:

- ClimFilter™ "Comfort" per filtri particellari.
- ClimFilter™ "Protezione" per filtri combinati.
- L'attuale packaging in plastica (consegnato fino ad esaurimento) è sostituito dal nuovo packaging in cartone.
- La codifica dei filtri abitacolo rimane invariata (698xxx, 715xxx) e cambia solo il tipo di packaging.(698xxx, 715xxx). Los cambios afectaran únicamente al tipo de embalaje.

Raccomandazioni Valeo per la riparazione

Scegli il corretto filtro abitacolo per la tua auto.

Il filtro ai polifenoli è consigliato per la massima protezione dei passeggeri.

Tutti i filtri abitacolo Valeo vengono forniti insieme alle relative istruzioni di montaggio per garantire una sostituzione ottimale.

Per un'aria più sana all'interno del veicolo, Valeo raccomanda di procedere alla pulizia e alla purificazione del circuito di aria condizionata ad ogni sostituzione del filtro abitacolo con Climpur® Valeo.

NL
Functie

De interieurfilter voorkomt dat schadelijke verontreinigende stoffen via de leidingen van de airconditioning en de ventilatie het interieur van het voertuig binnendringen.

Er zijn 3 verschillende technologieën interieurfilters:

- deeltjesfilters voor vaste verontreinigende stoffen: stof, teer, pollen.
- combinatiefilters voor vaste + niet-vaste verontreinigende stoffen: uitlaatgassen, onaangename geuren enz.
- polyfenolfilters voor allergieneutralisatie (pollen), vaste verontreinigende stoffen, schadelijke gassen, onaangename geuren.

Vervanging

Interieurfilters zijn belangrijk voor de veiligheid en het comfort, evenals voor de efficiënte werking van het airconditioningsysteem en moeten regelmatig worden vervangen - ieder jaar of na elke 15.000 km.

De interieurfilter bevindt zich vlakbij de luchtinlaat van de verdamper.

Problemen die het meest voorkomen bij interieur luchtfilters :

- Er wordt te weinig lucht het interieur in geblazen (slechte werking van de airconditioning, wasem verdwijnt langzamer...)
- Allergische reacties (niezen, irritatie van de luchtwegen...)
- Slechte luchtkwaliteit in het interieur (onaangename geuren, verontreiniging enz.)

Nieuwe Verpakking - KARTON

Valeo introduceert een nieuwe kartone verpakking voor het Interieur Filter assortiment:

- ClimFilter™ "Comfort" voor particle filters.
- ClimFilter™ "Protect" voor combined filters.
- De huidige plastic verpakkingen (zo lang de voorraad strekt) is vervangen door een nieuwe kartone verpakking.
- De referentienummers van de Interieur Filters blijven ongewijzigd (698xxx, 715xxx), alleen de verpakking verandert.

Aanbevelingen bij de reparatie

Kies het juiste interieurfilter, behorend bij het voertuig.

Voor de hoogste bescherming van bestuurder en passagier wordt het polyfenolfilter geadviseerd.

Bij alle Valeo interieurfilters zijn specifieke montage-instructies bijgesloten, zodat de filter zo efficiënt mogelijk vervangen kan worden.

Voor optimale luchtkwaliteit in het voertuig adviseert Valeo om na iedere vervanging van de interieurfilter het airconditioningsysteem een reinigings- en zuiveringsbehandeling te geven (Climpur Valeo).

PL
Funkcja

Filtr kabinowy zabezpiecza przed wnikaniem do wnętrza kabiny zewnętrznych szkodliwych zanieczyszczeń przez wloty systemu wentylacji i klimatyzacji.

Istnieją 3 różne technologie filtrów kabinowych.

- Filtry cząstek stałych chroni przed stałymi zanieczyszczeniami: kurzem i pyłkami.
- Filtr kombinowany chroni przed stałymi zanieczyszczeniami + zatrzymuje szkodliwe gazy i nieprzyjemne zapachy.
- Filtry z polifenolem neutralizujące alergeny (pyłki), wychwyłujące zanieczyszczenia stałe, szkodliwe gazy, nieprzyjemne zapachy.

Wymiana filtra

Dla zapewnienia bezpieczeństwa i komfortu jazdy jak również wydajności układu klimatyzacji niezwykle istotna jest regularna wymiana filtra kabinowego - co rok lub co 15.000 km (10.000 mil).

Filtr kabinowy znajduje się przy nawiewie powietrza lub przy parowniku.

Typowe problemy z filtrami kabinowymi.

- Niedostateczny nawiew powietrza do kabiny (osłabiona klimatyzacja, wolniejsze odparowywanie szyb)
- Reakcje alergiczne (kichanie, podrażnienia...)
- Niska jakość powietrza w kabinie (nieprzyjemne zapachy, zanieczyszczenia...)

Nowe opakowanie - KARTON

Valeo przedstawia nowe kartonowe opakowanie dla gamy filtrów kabinowych:

- ClimFilter™ "Comfort" dla filtrów cząstek stałych.
- ClimFilter™ "Protect" dla filtrów z aktywnym węglem.
- Obecne opakowanie plastikowe (filtry dostarczane w tym opakowaniu do wyczerpania zapasów) jest zastąpione przez nowe opakowanie kartonowe.
- Kodowanie numerów referencji filtrów kabinowych pozostaje bez zmian (698xxx, 715xxx), zmianie ulega jedynie rodzaj opakowania.

Zalecenia serwisowe

- Wybierz odpowiedni filtr kabinowy dopasowany do parametrów pojazdu.
- Dla najwyższej ochrony kierowcy i pasażerów zalecany jest filtr z polifenolem.
- Do zastosowań miejskich rekomenduj kombinowany filtr węglowy dla zwiększenia komfortu kierowcy i pasażerów.
- Korzystaj z instrukcji montażu filtra Valeo dołączonej do każdego opakowania by efektywnie wymienić filtr kabinowy.
- Zgodnie z rekomendacją Valeo, by promować zdrowsze powietrze w kabinie pojazdu, stosuj środek czyszczący i odkażający system A/C (ClimPur™) przy każdej wymianie filtra a także środek czyszczący wnętrze kabiny (ClimSpray™).

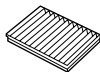

RU

Функция

Салонные фильтры препятствуют проникновению в салон вредных частиц вместе с потоком воздуха из системы кондиционирования и вентиляционных патрубков.

Существует 3 технологии салонных фильтров:

- частичный фильтр, защищающий от твердых частиц: грязь, смолы, пыльца...
- угольный фильтр, защищающий от твердых частиц + других видов загрязнения: выхлопные газы, неприятные запахи...
- полифеноловые фильтры для нейтрализации действия аллергенов (полена), плотных загрязняющих частиц, вредных газов, неприятных запахов

Замена

Для безопасности и комфорта водителя, а также для эффективной работы системы кондиционирования, рекомендуется регулярно менять салонный фильтр (ежегодно, или каждые 15000 км)

Салонный фильтр может находиться рядом с воздухопроводом или испарителем

Типичные проблемы с салонными фильтрами

- Снижение потока воздуха в салон (ниже уровень кондиционирования, запотевание стекол)
- Аллергические реакции (чихание, слезоточивость...)
- Плохой воздух в салоне (неприятный запах, частицы пыли...)

Новая картонная упаковка

Valeo представляет новую картонную упаковку для салонных фильтров.

- ClimFilter™ "Comfort" для фильтров без активированного угля.
- ClimFilter™ "Protect" для фильтров с активированным углем.
- Пластиковая упаковка фильтров (поставляется до окончания стока) заменяется новой картонной упаковкой.
- Артикулы остаются без изменений (698xxx, 715xxx), меняется только вид упаковки.

Рекомендации по замене

- Выберите наиболее подходящий фильтр в соответствии с параметрами Вашего автомобиля
- Для самой высокой степени защиты водителя и пассажиров рекомендуется использовать полифеноловый фильтр
- Специальные инструкции по установке прилагаются
- Valeo рекомендует использовать очиститель системы кондиционирования (ClimPur™) при каждой замене фильтра вместе с очистителем воздуха в салоне (ClimSpray™).

CZ

Funkce

Kabinový filtr zabráňuje pronikání škodlivin z ovzduší přes klimatizaci a ventilační otvory do kabiny vozu.

Existují 3 různé technologie kabinových filtrů:

- filtry pevných částic - pro pevné znečišťující látky: prach, dehet, pyl.
- kombinované filtry (s aktivním uhlíkem) - pro pevné znečišťující látky + další znečištění: výfukové plyny, pachy...
- polyfenolové filtry pro neutralizaci alergenů (pyly), zachycení pevných částic, škodlivých plynů, zápachu

Výměna

Základním pravidlem pro bezpečnost a komfort, stejně tak jako pro správné fungování klimatizace, je nutnost pravidelné výměny kabinového filtru, a to každý rok nebo každých 15.000 km.

Kabinový filtr může být umístěn blízko vstupu vzduchu do kabiny vozu nebo blízko výparníku.

Typické příznaky starého kabinového filtru:

- nedostatečný tok ventilovaného vzduchu do kabiny (nižší účinnost klimatizace, pomalejší odmlžení skla...)
- alergická reakce (kýchání, podráždění očí...)
- špatná kvalita vzduchu v kabině (zápach, znečištění ...)

Nové kartonové balení

Valeo zavádí nové kartonové balení pro svoji řadu kabinových filtrů:

- ClimFilter™ "Comfort" pro částicové filtry.
- ClimFilter™ "Protect" pro kombinované filtry s aktivním uhlíkem.
- Aktuálně používané plastové balení (dodávané do vyčerpání skladových zásob) bude nahrazeno novým kartonovým balením.
- Kódování objednávacích čísel kabinových filtrů zůstává nezměněno (698xxx, 715xxx), mění se pouze typ balení.

Doporučení pro údržbu

- Zvolte si správný kabinový filtr podle vozidla.
- Pro nejlepší ochranu řidiče i cestujících se doporučuje používat polyfenolové filtry.
- montážní postupy pro snadnou výměnu kabinových filtrů jsou obsaženy v každém balení.
- Valeo doporučuje provést vyčištění systému klimatizace přípravkem ClimPur při každé výměně kabinového filtru.

HR
Funkcija

Filter kabine sprečava ulazanje štetnih tvari iz zraka preko klima uređaja i ventilacijskih otvora u kabinu vozila.

Postoje 3 različite tehnologije filtera kabine:

- filteri krutih čestica - za krute onečišćujuće tvari: prašina, čađa, pelud
- kombinirani filteri (s aktivnim ugljikom) - za krute onečišćujuće tvari + drugo onečišćavanje: ispušni plinovi, loši mirisi...
- Filter s polifenolom za neutralizaciju alergeni tvari, krutih štetnih tvari, štetnih plinova, loših mirisa

Zamjena

Glavno pravilo za sigurnost i komfor, jednako kao i za ispravno funkcioniranje klima - uređaja je redovita izmjena filtera kabine, i to svake godine ili svakih 15.000 km.

Filter kabine može biti postavljen u blizini ulaza zraka u kabinu vozila ili u blizinu isparavanja.

Tipični simptomi starog filtera kabine

- nedovoljan protok ventilacijskog zraka u kabini (manji učinak klima - uređaja sporije čišćenje od zamagljenosti...)
- alergične reakcije (kihanje, nadraženost očiju...).
- loša kvaliteta zraka u kabini (loši mirisi, prjavišina...)

Nova kartonska ambalaža

Valeo uvodi novu kartonsku ambalažu za svoju seriju kabinskih filtera:

- ClimFilter™ "Comfort" za filtere za filtriranje sitnih čestica.
- ClimFilter™ "Protect" za kombinirane filtere s aktivnim ugljikom.
- Aktualno korištena ambalaža od plastike (koja se koristi do iscrpljenja postojeće zalihe) bit će zamijenjena novom kartonskom ambalažom.
- Kodiranje brojeva za narudžbu kabinskih filtera ostaje bez promjena (698xxx, 715xxx), mijenja se samo vrsta ambalaže.

Preporuke za održavanje

- Odaberite odgovarajući filter kabine za svoje vozilo.
- Za najveću zaštitu vozača i putnika preporuča se polifenolni filter.
- Postupci montaže za lakšu izmjenu filtera kabine nalaze se u svakom pakiranju.
- Valeo preporuča čišćenje sustava klima - uređaja dodatkom "ClimPur" prilikom svake izmjene filtera kabine.

HU
Funkcija

A pollenzűrő megakadályozza, hogy a légszennyezés a jármű szellőző- és klímaberendezésén keresztül az utastérbe jusson. 3 különböző típusú pollenzűrő létezik:

- szilárd részecske szűrő (por, korom, pollen,...)
- kombinált szűrők (aktív szén szűrő), amelyek kiszűrik a szilárd részecskéket és egyben bizonyos gázokat is (kipufogógáz, kellemetlen szagok,...)
- polyphenol szűrők az allergének (pollenek) semlegesítéséért, szilárd szennyeződések, káros gázok és rossz szagok kiszűréséért

Cseréje

A pollenzűrő kulcsfontosságú biztonsági és kényelmi felszerelés, amely biztosítja a klímaberendezés hatékony működését. Ezért évente vagy 15.000 km-enként cserélni kell.

A pollenzűrő általában a levegőbeszívó nyílás vagy a párologtató közelében található.

A pollenzűrővel kapcsolatos leggyakoribb problémák:

- A szellőző kevés levegőt juttat az utastérbe (kisebb hűtés, rossz páramentesítés...)
- Allergiás reakciók (tüsszentés, légúti irritáció...)
- Az utastér levegője rossz minőségű (szagok, légszennyezés...)

Új kartondobozos csomagolás

A Valeo pollenzűrői mostantól új, kartondobozos csomagolásban:

- ClimFilter™ "Comfort" - részecske szűrő.
- ClimFilter™ "Protect" - aktív szén szűrő.
- A jelenlegi bliszteres csomagolás csak a készlet erejéig kapható.
- A cikkszámok nem változnak (698xxx, 715xxx), csak a csomagolás újul meg.

A Valeo tanácsa

- Válassza a megfelelő pollenzűrőt járműtípusához.
- A legmagasabb szintű vezető & utas védelemért a polyphenolos pollenzűrő használata javasolt.
- Hatékonyabb teheti a munkafolyamatot, ha követi a szűrő csomagolásában található, a Valeo által mellékelte szerelési útmutatót.
- Az utastér levegője akkor lesz igazán tiszta és egészséges, ha a pollenzűrő cseréjével egyidejűleg speciális tisztítószerezellel tisztítja a szellőző- és klímaberendezést.

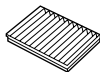

RO

Funcțione:

Filtrul de habitacul împiedică poluanții nocivi din aerul exterior să intre în habitacul vehiculului prin conductele de ventilație și de climatizare.

Există 3 tehnologii de filtre de habitacul:

- filtrele cu particulă împotriva poluanților de tip solid (prafuri, funingini, polenuri...)
- filtrele combinate care cumulează funcția anti-particulă cu funcția anti-poluare protejând de gazele nocive de eșapament și de mirosurile ambiante dezagreabile.
- Filtre cu polifenol pentru alergeni (polen), neutralizare, poluanți solizi, gaze nocive, mirosuri neplăcute

Înlocuire:

Indispensabil pentru siguranță și confort ca și pentru buna funcționare a climatizării, filtru de habitacul trebuie să fie înlocuit în fiecare an sau cel puțin la fiecare 15000 km.

Este situat sau aproape de intrarea de aer sau aproape de ventilator

Problemele cele mai frecvente legate de filtru de habitacul:

- Lipsa de aer pulsant în habitacul
- Reacții alergice în habitacul (strănături, iritații...)
- O calitate slabă a aerului în habitacul (mirosuri, poluare...)

Nou Ambalaj - Carton

Valeo prezintă noile ambalaje pentru filtre de habitacul:

- ClimFilter™ "Comfort" pentru filtre de particule.
- ClimFilter™ "Protect" pentru filtre combinate.
- Ambalajele actuale din pungi de plastic (furnizate până la epuizarea stocului) sunt înlocuite cu ambalaje noi de carton
- Codurile pentru filtre de habitacul rămân neschimbate (698xxx, 715xxx), doar tipul de ambalaj se schimbă.

Recomandările Valeo pentru reparație:

- Alegeți filtrul potrivit pentru habitacul în funcție de autovehicul.
- Filtrul cu polifenol este recomandat pentru o protecție maximă a conducătorului și a pasagerilor.
- Optimizați prestația d'voastră referindu-vă la notițele de montare livrate cu filtrele de habitacul Valeo.
- Pentru o calitate deosebită a aerului, utilizați un produs care purifică circuitul de climatizare la fiecare înlocuitor de filtru de habitacul (Climpur Valeo)

BG

Функции

Филтърът купе предпазва от проникване на вредните замърсители от околната среда в купето на автомобила чрез климатичната и вентилационна система.

Разработени са 2 технологии за филтър купе:

- Филтър за твърди частици (поленов) - за предпазване от навлизане на: прах, сажди, полени ...
- Комбиниран (карбонов) филтър за твърди частици + други замърсители: изгорели газове, лоши миризми ...

Подмяна

Необходимо е, както за сигурността и комфорта, така и за ефективната работа на климатичната система филтърта купе да се подменя редовно - всяка година или на 15 000 км.

Филтърът купе се намира близо до входа на вентилационните отвори или изпарителя

Типични проблеми при филтрите купе:

- Загуба на количеството навлизащ въздух в купето (влошена работа на климатика, замъгленост ...)
- Алергични реакции (кихане, дразнения ...)
- Занижено качество на въздуха в купето (лоши миризми, замърсеност)

Нова картонена опаковка

Valeo представя нови картонени опаковки за гамата на филтри купе

- ClimFilter™ "Comfort" филтър за твърди частици (поленов)
- ClimFilter™ "Protect" за комбиниран (карбонов) филтър
- Сегашната пластмасова опаковка (доставя се до изчерпване на наличностите) се заменя с нова картонена опаковка
- Номерацията на филтрите купе остава непроменена (698xxx, 715xxx), променя се само типа на опаковката

Препоръки при подмяна

- Изберете точния филтър купе според спецификациите на автомобилпроизводителя
- За градски условия филтърът купе е препоръчително да бъде с активен въглен (карбонов), за да осигури комфорт на шофьора и неговите спътници
- За по - бърз и лесен монтаж във всяка опаковка ще намерите инструкции за подмяна.
- Препоръката на Valeo за по - здравословен въздух в автомобила е при всяка подмяна на филтърта купе да се третира климатичната система със спрейовете за освежаване и пречистване.

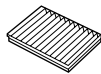

TU

İşlev

Kabin hava filtreleri dış ortamdan klima ve havalandırma kanalları yoluyla kabine girebilecek her türlü zararlı maddeyi engellemek üzere tasarlanmışlardır.

- Parçacık filtreleri katı maddeleri engellerler (toz, katran, polen...)
- Kombine filtreler katı maddelerle birlikte diğer kirleticileri de engeller (egzost dumanı, kötü kokular...)
- Polifenol filtreler alerji yapan maddeleri (polen) nötrleştirir; parçacıkları, zararlı gazları ve kötü kokuları filtreler.

Değişim

Güvenli ve konforlu bir ortamın sağlanması yanında klima sisteminin etkinliği için kabin hava filtrelerinin düzenli olarak her yıl ya da her 15000 kilometrede bir değiştirilmesi gerekir.

Kabin hava filtreleri hava kanalı girişi ya da evaporatör yanında konumlandırılmış olabilir.

Kabin hava filtreleriyle ilgili olası sorunlar:

- Kabine üflenen havada yetersizlik (daha az iklimlendirme, cam buğusunun geç açılması...)
- Sürücü ve yolculara alerjik tepkiler (hapçırma, göz sulanması...)
- Kabin içindeki kötü hava kalitesi (kötü kokular, kirlilik...)

Yeni karton ambalaj

Valeo kabin filtresi grubunda yeni karton ambalajlı sunum:

- ClimFilter™ "Comfort" Parçacık filtreleri.
- ClimFilter™ "Protect" Karbonlu kombine filtreler.
- Plastik ambalajların yerini yeni karton ambalajlar alacaktır (stok bitiminde)
- Kabin filtre referanslarında (698xxx, 715xxx) ambalaj değişimi sırasında herhangi bir farklılık olmayacaktır

Onarım tavsiyeleri

- Aracınız için doğru kabin filtresini seçin!.
- Sürücü ve yolcuların üst seviyede korunması için polifenol filtre önerilir
- Doğru uygulama yapılabilmesi için tüm Valeo kabin hava filtrelerinde montaj talimatnamesi mevcuttur.
- Araç içinde sürekli olarak sağlıklı ortam oluşturulabilmesi için her filtre değişiminde Valeo bir klima sistemi temizleyicisi ve arındırıcısı kullanılmasını önerir (Valeo Climpur).

GR

Λειτουργία :

Το φίλτρο καμπίνας εμποδίζει τις επιβλαβείς ρυπογόνες ουσίες του εξωτερικού αέρα να εισέλθουν στο εσωτερικό του οχήματος, μέσω των αεραγωγών του συστήματος κλιματισμού και εξαερισμού. Υπάρχουν 3 διαφορετικές τεχνολογίες φίλτρων καμπίνας:

- φίλτρα σωματιδίων για στερεούς ρύπους: σκόνη, πίσσα, γύρη..
- συνδυασμένα φίλτρα για στερεούς ρύπους + αέριους ρύπους: αέρια εξάτμισης, δυσάρεστες οσμές...
- φίλτρα Ιολυφενόλης για εξουδετέρωση αλλεργιογόνων (γύρη) & ρυολόγων ουσιών, ειβλαβή αέρια και δυσοσμίες. Ειλιέξτε το σωστό φίλτρο καμπίνας ανάλογα με το όχημα

Αντικατάσταση :

Είναι ουσιαστική για την άνεση και την ασφάλεια των επιβατών, όσο και για την καλή λειτουργία του συστήματος εξαερισμού. Το φίλτρο καμπίνας θα πρέπει να αντικαθίσταται μια φορά το χρόνο ή κάθε 15.000 χλμ. Το φίλτρο καμπίνας βρίσκεται συνήθως τοποθετημένο στην εισαγωγή αέρα του συστήματος εξαερισμού ή κοντά στον εξατμιστή. Συνήθη προβλήματα από την κακή κατάσταση του φίλτρου:

- Ελλιπής εξαερισμός, ψύξη ή θέρμανση του εσωτερικού του οχήματος.
- Πρόκληση αλλεργικών αντιδράσεων (φτερνίσματα, καταρροή ...).
- Δύσσομος και ακάθαρτος αέρας από το σύστημα εξαερισμού.

Νέα χάρτινη συσκευασία :

Η Valeo παρουσιάζει τη νέα χάρτινη συσκευασία για τη σειρά Φίλτρων Καμπίνας:

- ClimFilter™ "Comfort" για φίλτρα σωματιδίων.
- ClimFilter™ "Protect" για φίλτρα ενεργού άνθρακα.

Η τωρινή πλαστική συσκευασία (διαθέσιμη μέχρι εξαντήσεως των αποθεμάτων) αντικαθίσταται από τη νέα χάρτινη συσκευασία

- Η κωδικοποίηση των φίλτρων καμπίνας παραμένει απaráλλαχτη (698xxx, 715xxx), μόνο η συσκευασία αλλάζει.

Προτάσεις από την Valeo για την επισκευή :

Ειλιέξτε το σωστό φίλτρο καμπίνας ανάλογα με το όχημα.

Για τη μεγαλύτερη ασφάλεια των οδηγών και των επιβατών, συνιστάται το φίλτρο Ιολυφενόλης. Ειδικές οδηγίες συναρμολόγησης εσωκλείονται σε όλα τα φίλτρα καμπίνας της Valeo για γρήγορη και αποτελεσματική αντικατάσταση.

Για την βελτίωση της ποιότητας της ατμόσφαιρας εντός του εσωτερικού του οχήματος, η Valeo προτείνει να πραγματοποιείται μια αντιβακτηριακή επεξεργασία του συστήματος κλιματισμού κάθε φορά που αλλάξετε το φίλτρο καμπίνας (Climpur Valeo).



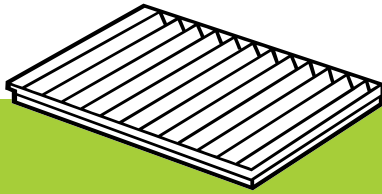

New Nouveau **Neu** Nuevo **Novo** Nuovo **Nieuw**
Nowy **Новый** Nové **Nou** Nouă **Нов** Yeni **Νέο**

12

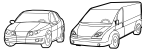

Valeo

13



47



Valeo

51

Valeo



129



Valeo

155



Valeo







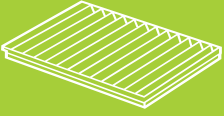





163

**Valeo****17**



| | | |
|--------|----------------------------|---|
| 701024 | NISSAN | Micra IV |
| 701025 | NISSAN RENAULT | Juke Fluence |
| 701026 | RENAULT | Clio IV |
| 701027 | FORD | Ford Focus C-Max, Galaxy (2006>), Kuga |
| 701028 | NISSAN | Qashqai |
| 715746 | DACIA RENAULT | Logan II, Sandero Capture, Clio IV |
| 715747 | FORD | Transit 2007 |
| 715748 | HYUNDAI | i20 |
| 715749 | LANCIA | Thema II |
| 715750 | MAZDA | Demio |
| 715751 | MERCEDES | GL (X166), M-Klasse (W166) |
| 715752 | OPEL | Meriva B |
| 715753 | PORSCHE | 911 (991), Boxster/Boxster S |
| 715754 | PORSCHE | 911 Carrera (991), Boxster |
| 715755 | CHRYSLER FIAT LANCIA | Ypsilon 500, Panda III Ypsilon II |
| 715756 | NISSAN | Micra |
| 715757 | FORD VOLVO | Kuga II V40 II |



|  | AC |  |  |  | PA   | CA   | PCA  | | |
|---|-----|---|---|---|---|---|--|---------------|---------------|
| ABARTH  | | | | | | | | | |
| Nuova 500 | A+ |  | ■■■ | 08/08 ▶ | 46723321 | 698866 | 77365763 | 715723 | |
| Nuova 500 | M+ |  | ■■■ | 08/08 ▶ | 46723321 | 698866 | 77365763 | 715723 | |
| Grande Punto | A+ |  | ■■■ | 09/07 ▶ | 55702456 | 715552 | 55702468 | 715553 | 701003 |
| Grande Punto | M+ |  | ■■■ | 09/07 ▶ | 55702456 | 715552 | 55702468 | 715553 | 701003 |
| Punto Evo | +/- | | ■■■ | 05/10 ▶ | 55702456 | 715552 | 55702468 | 715553 | 701003 |
| ALFA ROMEO  | | | | | | | | | |
| 145 | + | | ■■■ | 09/94 ▶ 06/01 | 46721923 | 698174 | | | |
| 146 | + | | ■■■ | 12/94 ▶ 06/01 | 46721923 | 698174 | | | |
| 147 (2000>) | +/- | x2 | ■■■ | 10/00 ▶ | | | 46799653 | 698747 | 701017 |
| 155 | + | | ■■■ | 01/93 ▶ 08/97 | 46721923 | 698174 | | | |
| 156 (97>2003) | |  | ■■■ | 09/97 ▶ 03/03 | 60653641 | 698197 | 60815647 | 698687 | |
| 156 (97>2003) | +/- |  | ■■■ | 09/97 ▶ 03/03 | 60653642 | 698689 | | | |
| 156 (2003>) | +/- | x2 | ■■■ | 04/03 ▶ 06/05 | | | 46799653 | 698747 | 701017 |
| 159 | + | | ■■■ | 09/05 ▶ | 71754158 | 715532 | 77363370 | 715533 | |
| 164 (87>98) | + | | ■■■ | 07/87 ▶ 09/98 | 7797229 | 698199 | | | |
| 166 (98>) | + | | ■■■ | 10/98 ▶ | | | 60814643 | 698688 | |
| Brera | + | | ■■■ | 01/06 ▶ | 77363481 | 715532 | 77363370 | 715533 | |
| Giulietta (2010>) | + | | ■■■ | 06/10 ▶ | 77365352 | 715705 | | | |
| GTV (95>2006) | +/- | | ■■■ | 12/94 ▶ 01/06 | 46721923 | 698174 | | | |
| GT | +/- | x2 | ■■■ | 09/03 ▶ | | | 46799653 | 698747 | 701017 |
| MiTo | +/- | | ■■■ | 08/08 ▶ | 55702456 | 715552 | 55702468 | 715553 | 701003 |
| Spider (95>2003) | +/- | | ■■■ | 04/95 ▶ 02/03 | 46721923 | 698174 | | | |
| Spider (2003>) | + | | ■■■ | 03/03 ▶ 03/06 | 46721923 | 698174 | | | |
| Spider (2006>) | +/- | | ■■■ | 08/06 ▶ | 77363481 | 715532 | 77363370 | 715533 | |
| AUDI  | | | | | | | | | |
| 80 (91>95) | + | | ■■■ | 05/93 ▶ 07/95 | 8A0819439 | 698164 | 8D0091800 | 715578 | |
| 90 (91>95) | +/- | | ■■■ | 07/93 ▶ 11/94 | 8A0819439 | 698164 | 8D0091800 | 715578 | |
| 100 (90>94) | +/- | | ■■■ | 12/90 ▶ 07/94 | | | 4A0091800 | 698684 | |
| A1 | +/- | | ■■■ | 07/10 ▶ | 6R0820367 | 715737 | 6R0819653 | 715727 | |
| A1 | +/- | | ■■■ | 06/00 ▶ | 600820367 | 698685 | 600819653 | 698739 | 701009 |
| A2 | - | | ■■■ | 06/00 ▶ | 600820367 | 698685 | 600819653 | 698739 | 701009 |
| A3 (96>2003) | +/- | | ■■■ | 09/96 ▶ 06/03 | 1H0819644B | 698159 | 1H0091800 | 698686 | |
| A3 (96>2003) | +/- | w/o Plastic Frame | ■■■ | 09/96 ▶ 06/03 | 1H0819644B | 698885 | | | |
| A3 (2003>) | +/- |  | ■■■ | 05/03 ▶ | 1K0819644A | 698800 | 1K1819653A | 698801 | 701001 |
| A3 (2003>) | +/- |  | ■■■ | 05/03 ▶ | | | 1K2819653 | 715665 | |
| A3 (2012>) | +/- | ultrafine | ■■■ | 03/12 ▶ | | | 500818653 | 715720 | 701020 |
| A4 (94>2000) | +/- | | ■■■ | 11/94 ▶ 11/00 | 8A0819439A | 698164 | 8D0091800 | 715578 | |
| A4 Avant (95>2001) | +/- | | ■■■ | 07/95 ▶ 09/01 | 8A0819439A | 698164 | 8D0091800 | 715578 | |
| A4 (2000>2007) | +/- | | ■■■ | 12/00 ▶ 10/07 | 8E0819439 | 698606 | 4B0819439C | 698683 | 701023 |
| A4 (2007>) | +/- | | ■■■ | 11/07 ▶ | 8K0819439 | 715579 | 8K0819439A | 715580 | |
| A4 Cabriolet (2002>) | +/- | | ■■■ | 04/02 ▶ 12/05 | 8E0819439 | 698606 | 4B0819439C | 698683 | 701023 |

















|  | AC |  |  |  | PA  OE Valeo | CA  OE Valeo | PCA  Valeo | |
|---|-----|---|---|---|---|---|---|--------|
| AUDI  (.../...) | | | | | | | | |
| A4 Cabriolet II (2006>) | +/- | | ■ ■ ■ | 01/06 ▶ | 8E0819439 | 698606 | 4B0819439C 698683 | 701023 |
| A5 (2007>) | + | | ■ ■ ■ | 06/07 ▶ | 8K0819439 | 715579 | 8K0819439A 715580 | |
| A5 Cabriolet (2009>) | +/- |  | ■ ■ ■ | 03/09 ▶ | 8K0819439 | 715579 | 8K0819439A 715580 | |
| A6 (94>97) | +/- | | ■ ■ ■ | 07/94 ▶ 09/97 | 4A0819439A | 715683 | 4A0091800 698684 | |
| A6 (97>2001) | +/- | | ■ ■ ■ | 04/97 ▶ 11/98 | 4A0819439A | 715683 | 4B0819439A 698682 | |
| A6 (97>2001) | +/- | | ■ ■ ■ | 11/98 ▶ 04/99 | | | 4B0819439C 698683 | 701023 |
| A6 (97>2001) | - | | ■ ■ ■ | 11/98 ▶ 05/01 | 8E0819439 | 698606 | 4B0819439C 698683 | 701023 |
| A6 (2001>2004) | + | | ■ ■ ■ | 06/01 ▶ 04/05 | | | 4B0819439C 698683 | 701023 |
| A6 (2004>) | + | x2 | ■ ■ ■ | 04/04 ▶ | 4F0819439 | 715500 | 4F0898438A 715501 | |
| A6 Allroad (2000>2006) | A+ | | ■ ■ ■ | 05/00 ▶ 04/06 | | | 4B0819439C 698683 | 701023 |
| A6 Allroad (2006>) | + | x2 | ■ ■ ■ | 05/06 ▶ 10/10 | 4F0819439 | 715500 | 4F0819439A 715501 | |
| A6 (2010>) | + | | ■ ■ ■ | 11/10 ▶ | | | 4H0819439 715733 | |
| A6 Allroad (2012>) | +/- | | ■ ■ ■ | 01/12 ▶ | | | 4H0819439 715733 | |
| A7 (2010>) | +/- | | ■ ■ ■ | 07/10 ▶ | | | 4H0819439 715733 | |
| A8 (94>2002) | +/- | x2 | ■ ■ ■ | 06/94 ▶ 09/02 | 4D0819439 | 698790 | 4D0819439A 698791 | |
| A8 (2002>2009) | +/- | | ■ ■ ■ | 10/02 ▶ 10/09 | | | 4E0819439A 698792 | |
| A8 (2009>) | + | | ■ ■ ■ | 11/09 ▶ | | | 4H0819439 715733 | |
| Cabriolet | +/- | | ■ ■ ■ | 06/93 ▶ 08/00 | 8A0819439 | 698164 | 8D0091800 715578 | |
| Coupé (88>96) | +/- | | ■ ■ ■ | 07/94 ▶ 01/96 | 8A0819439 | 698164 | 8D0091800 715578 | |
| Q3 | +/- |  | ■ ■ ■ | 06/11 ▶ | 1K0819644B | 698800 | 1K1819653B 698801 | 701001 |
| Q3 | +/- |  | ■ ■ ■ | 06/11 ▶ | | | 1K2819653B 715665 | |
| Q5 | +/- | | ■ ■ ■ | 11/08 ▶ | 8K0819439 | 715579 | 8K0819439A 715580 | |
| Q7 | A+ | | ■ ■ ■ | 03/06 ▶ | 7H0819631 | 715581 | 7H0819631A 698768 | |
| RS2 (94>95) | + | | ■ ■ ■ | 03/94 ▶ 06/95 | 8A0819439 | 698164 | 8A0819439B 715578 | |
| RS4 Quattro | + | | ■ ■ ■ | 06/00 ▶ 09/01 | 8A0819439A | 698164 | 8D0091800 715578 | |
| RS4 Quattro V8 FSi (2005>) | + | | ■ ■ ■ | 11/05 ▶ | | | 4B0819439C 698683 | 701023 |
| RS5 Coupé Quattro (2010>) | + | | ■ ■ ■ | 03/10 ▶ | 8K0819439 | 715579 | 8K0819439A 715580 | |
| RS6 Quattro | + | | ■ ■ ■ | 07/02 ▶ 09/04 | | | 4B0819439C 698683 | 701023 |
| RS6 (4F) (2008>) | + | | ■ ■ ■ | 04/08 ▶ | | | 4F0898438A 715501 | |
| R8 | A+ | | ■ ■ ■ | 04/07 ▶ | | | 4F0898438A 715501 | |
| S3 (98>2003) | A+ | | ■ ■ ■ | 11/98 ▶ 06/03 | | | 1J0819644A 698716 | 701016 |
| S3 (2006>) | +/- |  | ■ ■ ■ | 10/06 ▶ | 1K0819644B | 698800 | 1K1819653B 698801 | 701001 |
| S3 (2006>) | +/- |  | ■ ■ ■ | 10/06 ▶ | | | 1K2819653B 715665 | |
| S4 (97>99) | +/- | | ■ ■ ■ | 10/97 ▶ 01/99 | 8A0819439A | 698164 | 8D0091800 715578 | |
| S4 (99>2001) | +/- | | ■ ■ ■ | 02/99 ▶ 09/01 | | | 4A0091800 698684 | |
| S4 V8 (2003>) | + | | ■ ■ ■ | 03/03 ▶ 10/08 | 8E0819439 | 698606 | 4B0819439C 698683 | 701023 |
| S4 Cabriolet II (2004>) | + | | ■ ■ ■ | 02/04 ▶ | 8E0819439 | 698606 | 4B0819439C 698683 | 701023 |
| S4 (2008>) | + | | ■ ■ ■ | 11/08 ▶ | 8K0819439 | 715579 | 8K0819439A 715580 | |
| S5 | A+ | | ■ ■ ■ | 06/07 ▶ | 8K0819439 | 715579 | 8K0819439A 715580 | |
| S6 (94>97) | +/- | | ■ ■ ■ | 07/94 ▶ 10/97 | | | 4A0819439A 698684 | |
| S6 (99>2001) | + | | ■ ■ ■ | 09/99 ▶ 05/01 | | | 4B0819439C 698683 | 701023 |

|  | AC |  |  |  | PA  OE Valeo | CA  OE Valeo | PCA  Valeo | |
|---|-----|---|---|---|---|---|---|--------|
| AUDI  (.../...) | | | | | | | | |
| S6 (2001>2005) | + | | ■ ■ ■ | 06/01 ▶ 01/05 | | 4B0819439C | 698683 | 701023 |
| S6 (2006>2011) | + | | ■ ■ ■ | 06/06 ▶ 03/12 | 4F0819439 | 715500 | 4F0898438A | 715501 |
| S7 | + | | ■ ■ ■ | 04/12 ▶ | | | 4H0819439 | 715733 |
| S8 (96>2002) | +/- | x2 | ■ ■ ■ | 09/96 ▶ 09/02 | | | 4D0819439A | 698791 |
| S8 (2006>2011) | + | | ■ ■ ■ | 06/06 ▶ 03/12 | | | 4E0819439A | 698792 |
| S8 (2012>) | + | | ■ ■ ■ | 04/12 ▶ | | | 4H0819439 | 715733 |
| TT (98>2006) | +/- | w/o Plastic Frame | ■ ■ ■ | 10/98 ▶ 07/06 | 1H0819644B | 698885 | | |
| TT (98>2006) | +/- | | ■ ■ ■ | 10/98 ▶ 07/06 | 1H0819644B | 698159 | 1J0819644A | 698716 |
| TT II (2006>) | +/- |  | ■ ■ ■ | 08/06 ▶ | 1K0819644A | 698800 | 1K1819653A | 698801 |
| TT coupe | + |  | ■ ■ ■ | 05/06 ▶ | | | 1K2819653 | 715665 |
| TT Roadster | +/- |  | ■ ■ ■ | 01/07 ▶ | | | 1K2819653 | 715665 |
| BENTLEY  | | | | | | | | |
| Continental Flying Spur | +/- | x2 | ■ ■ ■ | 03/05 ▶ | | | 3D0898644, 3D0819619A | 698793 |
| Continental GT | + | x2 | ■ ■ ■ | 06/03 ▶ | | | 3D0898644, 3D0819619A | 698793 |
| Continental GTC | + | x2 | ■ ■ ■ | 12/06 ▶ | | | 3D0898644, 3D0819619A | 698793 |
| Mulsanne | + | | ■ ■ ■ | 10/09 ▶ | | | 4H0819439 | 715733 |
| BMW  | | | | | | | | |
| 1 series E87 | + | | ■ ■ ■ | 09/04 ▶ | 64316946629 | 715502 | 64319142115 | 715503 |
| 1 series E87 | +/- | | ■ ■ ■ | 09/04 ▶ | | | 64319142115 | 715503 |
| 1 Serie (2012>) | A+ | | ■ ■ ■ | 04/12 ▶ | | | 64119283497 | 715719 |
| 3 series E36 | +/- | | ■ ■ ■ | 12/90 ▶ 02/00 | 64119069895 | 698171 | | |
| 3 series E36 Compact | + | x2 | ■ ■ ■ | 02/94 ▶ 04/01 | 64319071933 | 698469 | | |
| 3 series E46 | + | | ■ ■ ■ | 03/98 ▶ | 64311000004 | 698489 | 64319071935 | 698750 |
| 3 series E90/E91/E92 | +/- | | ■ ■ ■ | 03/05 ▶ | 64316946629 | 715502 | 64319142115 | 715503 |
| 3 series E90/E91/E92 | +/- | | ■ ■ ■ | 03/05 ▶ | | | 64319142115 | 715503 |
| 3 Serie (2012) | A+ | | ■ ■ ■ | 04/12 ▶ | | | 64119283497 | 715719 |
| 5 series E34 | +/- |  | ■ ■ ■ | 11/87 ▶ 09/96 | 64311390836 | 698170 | | |
| 5 series E39 | + | x2 | ■ ■ ■ | 09/95 ▶ 04/04 | 64319069927 | 715685 | 64110008138 | 698246 |
| 5 series E60/E61 | +/- | x2 | ■ ■ ■ | 05/03 ▶ | 64316935822 | 698863 | 64316935823 | 698864 |
| 5 series (F10, F11, F18) | + | x2 | ■ ■ ■ | 10/09 ▶ | 64119163328 | 715715 | 64119163329 | 715690 |
| 6 series (F12, F13) | +/- | x2 | ■ ■ ■ | 03/10 ▶ | 64119163328 | 715715 | 64119163329 | 715690 |
| 6 series (E63/E64) | +/- | x2 | ■ ■ ■ | 09/03 ▶ | 64316935822 | 698863 | 64316935823 | 698864 |
| 7 series E32 | + |  | ■ ■ ■ | 09/86 ▶ 05/94 | 64311390836 | 698170 | | |
| 7 series E38 | + | x2 | ■ ■ ■ | 06/94 ▶ 08/01 | 64319069926 | 698838 | 64319070072 | 698470 |
| 7 series (E65/E66) | + | x2 | ■ ■ ■ | 09/01 ▶ | 64116921018 | 698856 | 64116921019 | 698857 |
| 7 series (E65/E66) | A+ | Rear AC | ■ ■ ■ | 11/01 ▶ | | | 64106907746 | 715582 |
| 7 series (F01, F02) | +/- | x2 | ■ ■ ■ | 10/08 ▶ | 64119163328 | 715715 | 64119163329 | 715690 |
| M3 E36 | +/- | | ■ ■ ■ | 06/92 ▶ 06/00 | 64119069895 | 698171 | | |
| M3 E46 | + | | ■ ■ ■ | 07/00 ▶ 06/06 | 64311000004 | 698489 | 64319071935 | 698750 |

|  | AC |  |  |  | PA  OE Valeo | CA  OE Valeo | PCA  Valeo |
|--|-----|---|---|---|---|---|---|
| BMW  (.../...) | | | | | | | |
| M3 (E90-92) | + | | ■ ■ ■ | 09/07 ▶ | | 64319159606 | 715712 |
| M3 E90M LCI | +/- | | ■ ■ ■ | 09/08 ▶ | | 64319159606 | 715712 |
| M5 E34 | +/- | | ■ ■ ■ | 07/88 ▶ | 64311390836 | 698170 | |
| M5 E39 | + | x2 | ■ ■ ■ | 07/99 ▶ | 64319069927 | 715685 | 64110008138 698246 |
| M5 E60 | + | x2 | ■ ■ ■ | 08/05 ▶ | 64316935822 | 698863 | 64316935823 698864 |
| M5 F10M | + | x2 | ■ ■ ■ | 09/11 ▶ | 64119163328 | 715715 | |
| M6 (E63/E64) | + | x2 | ■ ■ ■ | 03/05 ▶ | 64316935822 | 698863 | 64316935823 698864 |
| M6 (F12/F13) | + | x2 | ■ ■ ■ | 03/12 ▶ | | 64119272642 | 715690 |
| X1 E84 | +/- | | ■ ■ ■ | 10/09 ▶ | 64316946629 | 715502 | 64319142115 715503 |
| X1 E84 | A+ | | ■ ■ ■ | 09/11 ▶ | 64319142114 | 715502 | |
| X3 E83 | - | | ■ ■ ■ | 10/03 ▶ 09/10 | 64311000004 | 698489 | 64319071935 698750 |
| X3 F25 | + | | ■ ■ ■ | 09/10 ▶ | 64319237158 | 715714 | 64319237157 715713 |
| X5 E53 | +/- | | ■ ■ ■ | 01/00 ▶ 11/06 | 64318409043 | 698775 | 64318409044 698776 |
| X5 E70 | + | x2 | ■ ■ ■ | 03/07 ▶ | 64316945585 | 715583 | 64316945586 715584 |
| X6 E71 | A+ | x2 | ■ ■ ■ | 05/08 ▶ | 64316945585 | 715583 | 64316945586 715584 |
| X6 E71M | A+ | | ■ ■ ■ | 04/12 ▶ | 64316945585 | 715583 | |
| Z4 (E85/E86) | - | | ■ ■ ■ | 09/02 ▶ | | 64316915764 | 698862 |
| Z4 (E85/E86) | A+ | | ■ ■ ■ | 09/02 ▶ | 64316915763 | 698861 | 64316915764 698862 |
| Z4 (E89) | M+ | | ■ ■ ■ | 09/11 ▶ | 64319195193 | 698861 | |
| CADILLAC  | | | | | | | |
| BLS | - | | ■ ■ ■ | 04/06 ▶ | 6808601 | 698711 | 1808624 698710 701010 |
| CTS | + | | | 03/05 ▶ | | | 88957450 715671 |
| SRX | + | | | 01/04 ▶ | | | 88957450 715671 |
| STS | + | | | 05/05 ▶ | | | 88957450 715671 |
| CHEVROLET  | | | | | | | |
| Aveo | + | | ■ ■ ■ | 02/06 ▶ | 96539649 | 715535 | |
| Captiva (2006>2011) | + | | ■ ■ ■ | 06/06 ▶ 02/11 | 96800069 | 715654 | |
| Captiva (2011>) | + | | ■ ■ ■ | 02/11 ▶ | | | 22753219 715731 |
| Cruze | +/- | | ■ ■ ■ | 03/09 ▶ | 13271190 | 715658 | 13271191 715659 |
| Epica | +/- | | ■ ■ ■ | 05/06 ▶ | 96327366 | 715587 | |
| Evanda | +/- | | ■ ■ ■ | 08/02 ▶ 06/06 | 96327366 | 715587 | |
| Kalos | + | | ■ ■ ■ | 04/05 ▶ | 96539649 | 715535 | |
| Lacetti | + | | ■ ■ ■ | 01/05 ▶ | 96554421 | 715526 | |
| Magnus | + | | ■ ■ ■ | 03/05 ▶ | 96296618 | 715587 | |
| Malibu | + | | ■ ■ ■ | 01/12 ▶ | 13271191 | 715658 | 13271191 715659 |
| Matiz | +/- | | ■ ■ ■ | 01/05 ▶ | 96425700 | 715588 | |
| Nubira | + | | ■ ■ ■ | 01/05 ▶ | 96190645 | 698860 | |
| Orlando | + | | ■ ■ ■ | 03/11 ▶ | 13271190 | 715658 | 13271191 715659 |
| Rezzo | +/- | x2 | | 03/05 ▶ | 93740495 | 715536 | |
| Spark (2005>2009) | + | | ■ ■ ■ | 05/05 ▶ 12/09 | 96425700 | 715588 | |
| Spark (2010>) | + | | ■ ■ ■ | 01/10 ▶ | 95947238 | 715707 | 95215156 715710 |

|  | AC |  |  |  | PA  OE Valeo | CA  OE Valeo | PCA  Valeo | |
|--|-----|---|---|---|---|---|---|------------------------------------|
| CHEVROLET  (.../...) | | | | | | | | |
| Tacuma | +/- | x2 | | 03/05 ▶ | 93740495 | 715536 | | |
| Volt | + | | ■ ■ ■ ■ | 11/11 ▶ | | | 13271191 | 715659 |
| CHRYSLER  | | | | | | | | |
| 300C | +/- | | | ■ ■ ■ ■ | 09/04 ▶ | | 04596501AB | 715648 |
| Crossfire | +/- | | | ■ ■ ■ ■ | 07/03 ▶ | 5101438AA | 698169 | 5101439AA 698697 |
| Crossfire Roadster | +/- | | | ■ ■ ■ ■ | 07/03 ▶ | 5101438AA | 698169 | 5101439AA 698697 |
| Delta (2011>) | +/- | | | ■ ■ ■ ■ | 09/11 ▶ | 71736776 | 715686 | |
| Grand Voyager (2004>) | +/- |  | | ■ ■ ■ ■ | 07/04 ▶ 01/08 | | | 82205905 698865 |
| Grand Voyager (2004>) | +/- |  | | | 07/04 ▶ | | | 5072176AA 715611 |
| Grand Voyager (2008>) | +/- | | | ■ ■ ■ ■ | 02/08 ▶ | 68042866AA | 715711 | |
| PT Cruiser | +/- | | | ■ ■ ■ ■ | 06/00 ▶ | 50580040AA | 715534 | |
| Sebring (2006>) | +/- | | | ■ ■ ■ ■ | 03/07 ▶ 03/11 | 5058693AA | 715735 | |
| Voyager (2001>2008) | +/- |  | | ■ ■ ■ ■ | 03/01 ▶ 02/08 | | | 82205905 698865 |
| Voyager (2001>2008) | +/- |  | | | 03/01 ▶ 02/08 | | | 5072176AA 715611 |
| Ypsilon (2011>) | +/- | | | ■ ■ ■ ■ | 09/11 ▶ | 51854923 | 715755• | |
| CITROËN  | | | | | | | | |
| C Crossover | +/- | | | ■ ■ ■ ■ | 07/07 ▶ | 6447ZY | 715631 | 6447ZY 715623 |
| C1 | + | | | ■ ■ ■ ■ | 06/05 ▶ | 6447TV | 715515 | |
| C2 | + | | | ■ ■ ■ ■ | 09/03 ▶ | 6447NT | 698664 | |
| C2 | - | | | ■ ■ ■ ■ | 09/03 ▶ | | | 6447NV 698714 701014 |
| C2 | A+ | | | ■ ■ ■ ■ | 09/03 ▶ | 6447NT | 698664 | |
| C3 | M+ | | | ■ ■ ■ ■ | 04/02 ▶ 09/09 | 6447NT | 698664 | |
| C3 | - | | | ■ ■ ■ ■ | 04/02 ▶ 09/09 | | | 6447NV 698714 701014 |
| C3 | A+ | | | ■ ■ ■ ■ | 04/02 ▶ 09/09 | 6447NT | 698664 | |
| C3 (2009>) | M+ | x2 | | ■ ■ ■ ■ | 10/09 ▶ | 6447VY | 715556 | 6447VX 715557 701007 |
| C3 Picasso (2009>) | A+ | | | ■ ■ ■ ■ | 02/09 ▶ | 6447NT | 698664 | |
| C3 Picasso (2009>) | M+ | | | ■ ■ ■ ■ | 02/09 ▶ | 6447NT | 698664 | 6447NV 698714 701014 |
| C3 Pluriel | A+ | | | ■ ■ ■ ■ | 05/03 ▶ | 6447NT | 698664 | |
| C3 Pluriel | - | | | ■ ■ ■ ■ | 05/03 ▶ | | | 6447NV 698714 701014 |
| C3 Pluriel | A+ | | | ■ ■ ■ ■ | 05/03 ▶ | 6447NT | 698664 | |
| C4 | M+ | | | ■ ■ ■ ■ | 11/04 ▶ 10/09 | | | 6447NV 698714 701014 |
| C4 | A+ | | | ■ ■ ■ ■ | 11/04 ▶ 10/09 | 6479C2 | 698664 | |
| C4 II | M+ | | | ■ ■ ■ ■ | 11/09 ▶ | | | 6447NV 698714 701014 |
| C4 II | A+ | | | ■ ■ ■ ■ | 11/09 ▶ | 6479C2 | 698664 | |
| C4 Aircross | M+ | | | ■ ■ ■ ■ | 03/12 ▶ | 6479E9 | 715631 | |
| C4 Picasso | +/- | x2 | | ■ ■ ■ ■ | 09/06 ▶ | 6447XF | 715554 | 6447XG 715555 |
| C4 Grand Picasso | +/- | x2 | | ■ ■ ■ ■ | 10/06 ▶ | 6447XF | 715554 | 6447XG 715555 |
| C5 (2001>2004) | +/- | | | ■ ■ ■ ■ | 02/01 ▶ 08/04 | 6447HT | 698540 | 6447HV 698541 |
| C5 (2001>2004) | +/- | | | ■ ■ ■ ■ | 02/01 ▶ 08/04 | | | 6447HV 698541 |
| C5 (2004>2008) | A+ | | | ■ ■ ■ ■ | 09/04 ▶ 04/08 | 647904 | 715570 | 6447TC 698884 701002 |
| C5 (2008>) | + | | | ■ ■ ■ ■ | 05/08 ▶ | | | 647945 715635 |









|  | AC |  |  |  | PA  Valeo | CA  Valeo | PCA  Valeo | | |
|--|-----|---|---|---|--|--|---|---------------|---------------|
| CITROËN  (.../...) | | | | | | | | | |
| C6 (2005>2008) | + | | ■ ■ ■ | 10/05 ▶ 03/08 | 647904 | 715570 | 6447TC | 698884 | 701002 |
| C6 (2008>) | A+ | | ■ ■ ■ | 04/08 ▶ | | | 647945 | 715635 | |
| C8 | + | | ■ ■ ■ | 06/02 ▶ | 6447LZ | 698738 | 6447SP | 715558 | 701013 |
| DS3 | + | x2 | ■ ■ ■ | 03/10 ▶ | 6447WY | 715556 | 6447VX | 715557 | 701007 |
| DS4 | A+ | | ■ ■ ■ | 04/11 ▶ | 6479C2 | 698664 | 647975 | 698714 | 701014 |
| DS5 | - | x2 | ■ ■ ■ | 10/11 ▶ | 6447XF | 715554 | 6447XG | 715555 | |
| Evasion (94>2002) | +/- | x3 | ■ ■ ■ | 07/94 ▶ 05/02 | 6447HO | 715530 | | | |
| Evasion (94>2002) | +/- | x3 | ■ ■ ■ | 07/94 ▶ 05/02 | 6447H1 | 715530 | | | |
| Saxo (96>99) | +/- | | ■ ■ ■ | 03/96 ▶ | 6441G9 | 715589 | | | |
| Synergie (95>2002) | +/- | x3 | ■ ■ ■ | 10/95 ▶ 05/02 | 6447HO, 6447H1 | 715530 | | | |
| Xantia | +/- | | ■ ■ ■ | 03/93 ▶ 05/02 | 6447Z4 | 698146 | | | |
| Xsara (N1) (97>2000) | + |  | ■ ■ ■ | 07/97 ▶ 08/00 | 6447Z4 | 698146 | 6447SR | 715677 | |
| Xsara (N1) (97>2000) | - |  | ■ ■ ■ | 07/97 ▶ 08/00 | 6447Z4 | 698146 | | | |
| Xsara Break (N2) | + |  | ■ ■ ■ | 07/97 ▶ | 6447HP | 698657 | 6447SQ | 715629 | |
| Xsara Coupe (N0) | + |  | ■ ■ ■ | 02/99 ▶ | 6447HP | 698657 | 6447SQ | 715629 | |
| Xsara (2000>2005) | + |  | ■ ■ ■ | 09/00 ▶ 08/05 | 6447FG | 698731 | | | |
| Xsara (2000>2005) | M+ |  | ■ ■ ■ | 09/00 ▶ 08/05 | 6447HP | 698657 | 6447SQ | 715629 | |
| Xsara Picasso | A+ | | ■ ■ ■ | 12/99 ▶ | 6447FF | 698680 | 6447LN | 715612 | |
| CITROËN  | | | | | | | | | |
| Berlingo (96>2002) | +/- | | ■ ■ ■ | 07/96 ▶ 12/00 | 6447Z4 | 698146 | 6447SR | 715677 | |
| Berlingo (96>2002) | + |  | ■ ■ ■ | 12/00 ▶ 12/02 | 6447Z4 | 698146 | 6447SR | 715677 | |
| Berlingo (96>2002) | + |  | ■ ■ ■ | 12/00 ▶ 12/02 | 6447HP | 698657 | | | |
| Berlingo (2002>) | + |  | ■ ■ ■ | 12/02 ▶ | 6447Z4 | 698146 | | | |
| Berlingo (2002>) | + |  | ■ ■ ■ | 12/02 ▶ | 6447HP | 698657 | 6447SQ | 715629 | |
| Berlingo (2008>) | + | x2 | ■ ■ ■ | 04/08 ▶ | 6447XF | 715554 | 6447XG | 715555 | |
| Dispatch (2004>2006) | +/- | | ■ ■ ■ | 01/04 ▶ 12/06 | 6447KR | 698657 | | | |
| Dispatch (2007>) | + | | ■ ■ ■ | 01/07 ▶ | 6447YK | 715614 | 6447YN | 715613 | |
| Jumper (94>2001) | +/- |  | ■ ■ ■ | 02/94 ▶ 12/01 | 6447SY | 698858 | | | |
| Jumper (2002>2006) | + |  | ■ ■ ■ | 01/02 ▶ 06/06 | 6447SY | 698858 | | | |
| Jumper (2006>) | + | | ■ ■ ■ | 07/06 ▶ 09/11 | 6447YC | 715636 | | | |
| Jumper (2011>) | +/- | | ■ ■ ■ | 10/11 ▶ | 6479C9 | 715636 | | | |
| Jumpy I | +/- | x3 | ■ ■ ■ | 09/95 ▶ 12/03 | 6447HO, 6447H1 | 715530 | | | |
| Jumpy I (Facelift) | + | | ■ ■ ■ | 01/04 ▶ 12/06 | 6447LZ | 698738 | 6447SP | 715558 | 701013 |
| Jumpy II | + | | ■ ■ ■ | 01/07 ▶ | 6447YN | 715614 | 6447YK | 715613 | |
| Nemo | +/- |  | ■ ■ ■ | 02/08 ▶ | 647962 | 715616 | | | |
| Nemo | +/- |  | ■ ■ ■ | 07/05 ▶ | 647984 | 715552 | | | |
| Relay (94>2001) | +/- |  | ■ ■ ■ | 02/94 ▶ 12/01 | 6447YL | 698858 | | | |
| Relay (2002>2006) | + | | ■ ■ ■ | 01/02 ▶ 06/06 | 6447TY | 698858 | | | |
| Relay (2006>) | + | | ■ ■ ■ | 07/06 ▶ | 6479C9 | 715636 | | | |

|  | AC |  |  |  | PA   | CA   | PCA  | | |
|---|-----|---|---|---|---|---|--|---------------|----------------|
| DACIA  | | | | | | | | | |
| Duster | +/- | | ■■■ | 03/10 ▶ | 272775374R | 698753 | | | |
| Logan (2004>) | +/- | | ■■■ | 09/04 ▶ | 7701062227 | 698753 | | | |
| Logan (2013>) | +/- | | ■■■ | 01/13 ▶ | 272773016R | 715746• | 272770567R | 715725 | 701026• |
| Sandero | | | ■■■ | 06/08 ▶ | 7701062227 | 698753 | | | |
| Sandero 2 | +/- | | ■■■ | 10/12 ▶ | 272773016R | 715746• | 272770567R | 715725 | 701026• |
| DACIA  | | | | | | | | | |
| Lodgy | | | ■■■ | 03/12 ▶ | 272772835R | 698753 | | | |
| DAEWOO  | | | | | | | | | |
| Kalos | +/- | | ■■■ | 09/02 ▶ 03/05 | 96539649 | 715535 | | | |
| Lacetti | + | | ■■■ | 10/03 ▶ 12/04 | 96554421 | 715526 | | | |
| Leganza | + | | ■■■ | 09/97 ▶ 12/04 | 96207422 | 698859 | | | |
| Nubira | + | | ■■■ | 11/96 ▶ 07/03 | 96190645 | 698860 | | | |
| Nubira | + | | ■■■ | 07/03 ▶ | 96554421 | 715526 | | | |
| Matiz | + | | ■■■ | 03/05 ▶ | 96425700 | 715588 | | | |
| Rezzo | + | x2 | | 09/00 ▶ 03/05 | 93740495 | 715536 | | | |
| Tacuma | + | x2 | | 09/00 ▶ 03/05 | 93740495 | 715536 | | | |
| DAIHATSU  | | | | | | | | | |
| Charade | + | | ■■■ | 05/11 ▶ | 871390D010 | 715620 | 8713950060 | 715730 | 701021 |
| Cuore VII | +/- | | ■■■ | 05/03 ▶ 08/07 | 99906850M2-036 | 715590 | | | |
| Cuore VIII | + | | ■■■ | 09/07 ▶ | | | 08975K2000-100 | 715695 | |
| Sirion II | + | | ■■■ | 01/05 ▶ | 99906850M2-038 | 715637 | | | |
| Terios | + | | ■■■ | 05/06 ▶ | | | 08975K2000-100 | 715695 | |
| DODGE  | | | | | | | | | |
| Avenger | + | | ■■■ | 07/07 ▶ 11/10 | 5058693AA | 715735 | | | |
| Caliber | +/- | | ■■■ | 07/06 ▶ 05/11 | 5058693AA | 715735 | 5058381AA | 715537 | |
| Journey | + | | ■■■ | 06/08 ▶ 05/11 | 5058693AA | 715735 | 5058381AA | 715537 | |
| Magnum | + | | ■■■ | 09/04 ▶ | | | 04596501AB | 715648 | |
| Nitro | + | | ■■■ | 06/07 ▶ | 68033193AA | 715696 | | | |
| DODGE  | | | | | | | | | |
| Sprinter | +/- | | ■■■ | 02/95 ▶ 05/06 | 05103600AA | 698840 | | | |
| FIAT  | | | | | | | | | |
| 500 | +/- | | ■■■ | 07/07 ▶ 06/12 | 46723321 | 698866 | 77365763 | 715723 | |
| 500 | +/- | | ■■■ | 07/12 ▶ | 51854923 | 715755• | | | |
| 500C | +/- | | ■■■ | 09/09 ▶ | 46723321 | 698866 | 77365763 | 715723 | |
| Albea | +/- | | ■■■ | 01/02 ▶ | 7082301 | 715615 | | | |
| Barchetta | +/- | | ■■■ | 01/95 ▶ | 46721374 | 698198 | | | |
| Brava | + |  | ■■■ | 06/95 ▶ | 46412715 | 698689 | | | |

|  | AC |  |  |  | PA   | CA   | PCA  | | |
|---|-----|---|---|---|---|---|--|---------------|---------------|
| FIAT  (.../...) | | | | | | | | | |
| Brava | +/- |  | ■■■ | 06/95 ▶ | 46442422 | 698197 | 46768502 | 698687 | |
| Bravo I | +/- |  | ■■■ | 06/95 ▶ 03/07 | 46412715 | 698689 | | | |
| Bravo I | +/- |  | ■■■ | 06/95 ▶ 03/07 | 46442422 | 698197 | 60815647 | 698687 | |
| Bravo II | +/- | | ■■■ | 04/07 ▶ | 46723435 | 715686 | 46723435 | 698692 | |
| Coupe | +/- | | ■■■ | 07/96 ▶ | 71712596 | 698174 | | | |
| Croma (91>96) | + | | ■■■ | 01/91 ▶ 12/96 | 60811242 | 698199 | | | |
| Croma II (2005>) | + |  | ■■■ | 06/05 ▶ | | | 46844822 | 698710 | 701010 |
| Freemont | + | | ■■■ | 08/11 ▶ | 05058696AA | 715735 | K05058693AA | 715537 | |
| Idea | + |  w/o Plastic Frame | ■■■ | 10/03 ▶ | 46723331 | 698867 | | | |
| Linea | +/- | | ■■■ | 07/07 ▶ | 77364561 | 715616 | | | |
| Marea | +/- |  | ■■■ | 07/96 ▶ | 46412715 | 698689 | | | |
| Marea | +/- |  | ■■■ | 07/96 ▶ | 46442422 | 698197 | 46768502 | 698687 | |
| Marengo (185) (95>) | +/- |  | ■■■ | 01/95 ▶ | 46412715 | 698689 | | | |
| Marengo (185) (95>) | +/- |  | ■■■ | 01/95 ▶ | 46442422 | 698197 | | | |
| Multipla | +/- | | ■■■ | 11/98 ▶ | 46794399 | 698454 | | | |
| Palio | + | | ■■■ | 07/96 ▶ | 7078711 | 698691 | | | |
| Palio | + | | ■■■ | 06/99 ▶ | 7079682 | 698690 | | | |
| Palio | + | | ■■■ | 09/99 ▶ | 7082301 | 715615 | | | |
| Panda (2003>) | +/- | | ■■■ | 09/03 ▶ | 46723321 | 698866 | 77365763 | 715723 | |
| Panda 312 (Nuova) | +/- | | ■■■ | 01/12 ▶ | 51854923 | 715755* | | | |
| Punto (93>99) | | | ■■■ | 07/93 ▶ 09/99 | 46721374 | 698198 | | | |
| Punto II (99>2003) | +/- | w/o Plastic Frame | ■■■ | 03/01 ▶ 06/03 | 46723331 | 698867 | | | |
| Punto II (99>2003) | + | | ■■■ | 07/99 ▶ 06/03 | 46770834 | 698535 | 46723245 | 698839 | |
| Punto II (2003>2005) | + | w/o Plastic Frame | ■■■ | 07/03 ▶ | 46723331 | 698867 | | | |
| Punto II (2003>2005) | + | | ■■■ | 07/03 ▶ | 46770834 | 698535 | 46723245 | 698839 | |
| Punto Evo (2009>) | +/- | | ■■■ | 10/09 ▶ | 55702456 | 715552 | 55702456 | 715553 | 701003 |
| Grande Punto | +/- | | ■■■ | 10/05 ▶ | 55702456 | 715552 | 55702456 | 715553 | 701003 |
| Qubo | +/- |  | ■■■ | 10/09 ▶ | 77364561 | 715616 | | | |
| Qubo | + |  | ■■■ | 07/10 ▶ | 55702456 | 715552 | 77365764 | 715553 | 701003 |
| Sedici | + | | ■■■ | 04/06 ▶ | 71743821 | 698886 | | | |
| Siena (97>2001) | +/- | | ■■■ | 11/97 ▶ 02/98 | 7078711 | 698691 | | | |
| Siena (97>2001) | + | | ■■■ | 02/98 ▶ 12/01 | 7079682 | 698690 | | | |
| Siena (2002>) | + | | ■■■ | 01/02 ▶ | 7082301 | 715615 | | | |
| Stilo (2001>2007) | +/- | | ■■■ | 09/01 ▶ 03/07 | 46723435 | 715686 | 46723435 | 698692 | |
| Strada Pick Up | +/- | | ■■■ | 03/99 ▶ 03/03 | 7079682 | 698690 | | | |
| Strada Pick Up | + | | ■■■ | 04/03 ▶ | 7082301 | 715615 | | | |
| Tempra | +/- | | ■■■ | 11/89 ▶ 01/96 | 71712596 | 698174 | | | |
| Tipo | + | | ■■■ | 01/88 ▶ 10/95 | 71712595 | 698174 | | | |
| Ulysse (94>2002) | + | x3 | ■■■ | 06/94 ▶ 08/02 | 1475478080, 1475479080 | 715530 | | | |











|  | AC |  |  |  | PA   | CA   | PCA  | | |
|---|-----|---|---|---|---|---|--|----------------|----------------|
| FIAT  (.../...) | | | | | | | | | |
| Ulysse (2002>) | +/- | | ■ ■ ■ ■ | 09/02 ▶ | 1484383080 | 698738 | 9655190480 | 715558 | 701013 |
| FIAT  | | | | | | | | | |
| Doblo (2000>2004) | + | w/o Plastic Frame | ■ ■ ■ ■ | 02/01 ▶ 12/03 | 46723331 | 698867 | | | |
| Doblo (2000>2005) | + | | ■ ■ ■ ■ | 10/00 ▶ 12/05 | 46722862 | 698535 | 46723245 | 698839 | |
| Doblo (2004>2005) | + | w/o Plastic Frame | ■ ■ ■ ■ | 01/04 ▶ 12/05 | 46723331 | 698867 | | | |
| Doblo (2006>) | + | w/o Plastic Frame | ■ ■ ■ ■ | 01/06 ▶ | 46723331 | 698867 | 46723245 | 698839 | |
| Doblo (2010>) | + | | ■ ■ ■ ■ | 01/10 ▶ | 77364561 | 715616 | | | |
| Ducato (94>2001) | +/- | | ■ ■ ■ ■ | 02/94 ▶ 12/01 | 1312766080 | 698858 | | | |
| Ducato (2002>) | +/- | | ■ ■ ■ ■ | 01/02 ▶ 06/06 | 1312766080 | 698858 | | | |
| Ducato (2006>) | + | | ■ ■ ■ ■ | 07/06 ▶ | 77364063 | 715636 | | | |
| Fiorino | +/- |  | ■ ■ ■ ■ | 12/07 ▶ | 77364561 | 715616 | | | |
| Fiorino | + |  | ■ ■ ■ ■ | 12/07 ▶ | 55702456 | 715552 | 77365764 | 715553 | 701003 |
| Scudo (95>2003) | + | x3 | ■ ■ ■ ■ | 07/95 ▶ 12/03 | 1475478080, 1475479080 | 715530 | | | |
| Scudo (2004>2006) | + | | ■ ■ ■ ■ | 01/04 ▶ 12/06 | 1484383080 | 698738 | 1483883080 | 715558 | 701013 |
| Scudo II | + | | ■ ■ ■ ■ | 01/07 ▶ | 1497498080 | 715614 | 1497497080 | 715613 | |
| FORD  | | | | | | | | | |
| B-Max | +/- | | ■ ■ ■ ■ | 03/12 ▶ | 1541456 | 715660 | 1566997 | 715661 | |
| C-Max (CB3) | +/- | | ■ ■ ■ ■ | 03/07 ▶ 08/10 | 1315686 | 698882 | 1315687 | 698883 | 701027• |
| C-Max (B7) | +/- | | ■ ■ ■ ■ | 08/10 ▶ | | | 1776360 | 715757• | |
| Cougar | A+ | | ■ ■ ■ ■ | 01/99 ▶ 04/02 | 1097670 | 698168 | 1488903 | 715674 | |
| Fiesta (95>2002) | + | | ■ ■ ■ ■ | 08/95 ▶ 03/02 | 1004051 | 698201 | 1120475 | 715617 | |
| Fiesta (2002>2008) | +/- | | ■ ■ ■ ■ | 03/02 ▶ 09/08 | 1204459 | 698694 | 1353269 | 698693 | 701004 |
| Fiesta (2008>) | +/- | | ■ ■ ■ ■ | 11/08 ▶ | 1541456 | 715660 | 1566997 | 715661 | |
| Focus (98>2004) | + | | ■ ■ ■ ■ | 10/98 ▶ 09/04 | 1062253 | 698487 | 1139654 | 698695 | 701005 |
| Focus II (2004>2011) | +/- | | ■ ■ ■ ■ | 09/04 ▶ 02/11 | 1354952 | 715510 | 1395953 | 715511 | 701011 |
| Focus III | +/- | | ■ ■ ■ ■ | 03/11 ▶ | | | 1709013 | 698883 | 701027• |
| Focus III | +/- | | ■ ■ ■ ■ | 03/11 ▶ | | | 1776360 | 715757• | |
| Focus C-MAX | +/- | | ■ ■ ■ ■ | 06/03 ▶ | 1315686 | 698882 | 1315687 | 698883 | 701027• |
| Fusion | +/- | | ■ ■ ■ ■ | 06/02 ▶ | 1204459 | 698694 | 1353269 | 698693 | 701004 |
| Galaxy (95>2000) | +/- | | ■ ■ ■ ■ | 05/95 ▶ 03/00 | 7420372 | 698247 | 1113627 | 698696 | |
| Galaxy (2000>2006) | +/- | | ■ ■ ■ ■ | 04/00 ▶ 03/06 | 7420372 | 698247 | 1148366 | 698696 | |
| Galaxy (2006>) | + | | ■ ■ ■ ■ | 04/06 ▶ | 1315686 | 698882 | 1315687 | 698883 | 701027• |
| Galopper | + | | ■ ■ ■ ■ | 11/12 ▶ | | | 1709013 | 715757• | |
| Ka | +/- | | ■ ■ ■ ■ | 09/96 ▶ 11/08 | 1004051 | 698201 | 1120475 | 715617 | |
| Ka | +/- | | ■ ■ ■ ■ | 12/08 ▶ | 1557375 | 698866 | 1673744 | 715723 | |
| Kuga | +/- | | ■ ■ ■ ■ | 04/08 ▶ | 1315686 | 698882 | 1415687 | 698883 | 701027• |
| Maverick (93>98) | + | | ■ ■ ■ ■ | 02/93 ▶ 03/98 | 5029916 | 698707 | | | |
| Maverick (2000>) | + | | ■ ■ ■ ■ | 12/00 ▶ | 4416570 | 698893 | | | |
| Mondeo (93>96) | + | | ■ ■ ■ ■ | 01/93 ▶ 08/96 | 7180932 | 698168 | | | |
| Mondeo (93>2000) | +/- |  | ■ ■ ■ ■ | 01/93 ▶ 09/00 | | | 1488903 | 715674 | |





|  | AC |  |  |  | PA   | CA   | PCA  | |
|---|-----|---|---|---|---|---|--|-----------------------|
| FORD  (.../...) | | | | | | | | |
| Mondeo (96>2000) | + | | ■■■ | 08/96 ▶ 10/00 | 1097670 | 698168 | | |
| Mondeo (2000>2003) | +/- | | ■■■ | 10/00 ▶ 05/03 | 1119613 | 698779 | | |
| Mondeo (2000>2003) | - | | ■■■ | 10/00 ▶ 05/03 | | | 1119616 | 698745 |
| Mondeo (2000>2003) | A+ | | ■■■ | 10/00 ▶ 05/03 | 1119613 | 698779 | 1119616 | 698745 |
| Mondeo (2003>2005) | M+ | | ■■■ | 06/03 ▶ 04/05 | 1119613 | 698779 | 1119616 | 698745 |
| Mondeo (2005>2007) | +/- | | ■■■ | 05/05 ▶ 05/07 | | | 1119616 | 698745 |
| Mondeo (2005>2007) | A+ | | ■■■ | 05/05 ▶ 05/07 | 1119613 | 698779 | | |
| Mondeo (2007>) | M+ | | ■■■ | 06/07 ▶ | 1315686 | 698882 | 1315687 | 698883 701027• |
| Puma | +/- | | ■■■ | 03/97 ▶ | 1004051 | 698201 | 1120475 | 715617 |
| Ranger | +/- | | ■■■ | 11/11 ▶ | 1718237 | 715745 | | |
| S-Max | +/- | | ■■■ | 04/06 ▶ | 1315686 | 698882 | 1315687 | 698883 701027• |
| StreetKa | + | | ■■■ | 11/02 ▶ | 1004051 | 698201 | 1120475 | 715617 |
| Transit 2006 | + | | ■■■ | 06/06 ▶ | | | 1748479 | 715747• |
| Turnier | | | ■■■ | 01/05 ▶ 04/11 | 1354952 | 715510 | 1395953 | 715511 701011 |
| Turnier | +/- | | ■■■ | 05/11 ▶ | 1315686 | 698882 | | |
| FORD  | | | | | | | | |
| Courier (96>) | +/- | | ■■■ | 10/96 ▶ | 1004051 | 698201 | 1120475 | 715617 |
| Tourneo Connect | + | | ■■■ | 05/02 ▶ | 1062253 | 698487 | 1139654 | 698695 701005 |
| Transit (2000>) | + | | ■■■ | 01/00 ▶ | 4042703 | 698762 | | |
| Transit (2006>) | +/- | | ■■■ | 08/06 ▶ | 1748480 | 715742 | | |
| Transit Connect | - | | ■■■ | 05/02 ▶ | 1062253 | 698487 | 1139654 | 698695 701005 |
| HONDA  | | | | | | | | |
| Accord VII Coupe (97>) | + | x2 | ■■■ | 10/97 ▶ 06/02 | 80291S84A01 | 715593 | | |
| Accord VII (98>2003) | + | | ■■■ | 10/98 ▶ 01/03 | 79370S1AG01 | 715573 | | |
| Accord VIII (2003>) | + | | ■■■ | 02/03 ▶ | 80292SDCA01 | 698868 | 80292SFY003 | 715678 |
| Acura CL | +/- | x2 | ■■■ | 02/01 ▶ 12/04 | 80291S84A01 | 715593 | | |
| City | + | | ■■■ | 12/08 ▶ | 80291TF0E01 | 715692 | | |
| Civic V (MA/MB) (95>2001) | +/- | | ■■■ | 01/95 ▶ 03/01 | 79831ST3E01 | 698819 | | |
| Civic V (MA/MB) (95>2001) | - | | ■■■ | 01/95 ▶ 03/01 | 80290ST3E01 | 698869 | | |
| Civic V (EJ/EK) (95>2001) | + | | ■■■ | 10/95 ▶ 03/01 | 79831ST3E01 | 698819 | | |
| Civic V (EJ/EK) (95>2001) | - | | ■■■ | 10/95 ▶ 03/01 | 80290ST3E01 | 698869 | | |
| Civic V (EJ*) (96>2000) | + | | ■■■ | 03/96 ▶ 03/00 | 79831ST3E01 | 698819 | | |
| Civic V (EJ*) (96>2000) | - | | ■■■ | 03/96 ▶ 03/00 | 80290ST3E01 | 698869 | | |
| Civic Aerodeck (97>) | + | | ■■■ | 09/97 ▶ 03/01 | 80291ST3505 | 698869 | | |
| Civic (EP) (2001>) | + | x2 | ■■■ | 04/01 ▶ 12/05 | 80292S5A003 | 698735 | | |
| Civic (2006>) | + | | ■■■ | 01/06 ▶ | 80292SMGE01 | 715540 | 80292SFY003 | 715678 |
| Civic (2006>) (Hybrid) | +/- | | ■■■ | 05/06 ▶ | 80292SDCA01 | 698868 | | |
| CR-V (97>2002) | + | | ■■■ | 01/97 ▶ 02/02 | 80291ST3E01 | 698869 | | |
| CR-V (97>2002) | + | | ■■■ | 01/97 ▶ 02/02 | 79831ST3E01 | 698819 | | |
| CR-V (2002>2006) | - | x2 | ■■■ | 03/02 ▶ 12/06 | 80292S5A003 | 698735 | | |
| CR-V (2007>) | + | | ■■■ | 01/07 ▶ | 80292SNW01 | 698868 | 80292SFY003 | 715678 |











|  | AC |  |  |  | PA  OE Valeo | CA  OE Valeo | PCA  Valeo |
|--|-----|---|---|---|---|---|---|
| HONDA  (.../...) | | | | | | | |
| FR-V (2004>) | +/- | x2 | ■■■ | 10/04 ▶ | 80292SCAE11 | 698735 | |
| HR-V | + | x2 | ■■■ | 10/98 ▶ | 80291SZHE01 | 715594 | |
| CR-Z (2010>) | + | | ■■■ | 06/10 ▶ | 80291TF0E01 | 715692 | |
| Insight (2000>) | +/- | | ■■■ | 03/00 ▶ | 80291ST3E01 | 698869 | |
| Insight (2000>) | + | | ■■■ | 03/00 ▶ | 79831ST3E01 | 698819 | |
| Insight (2009>) | - | | ■■■ | 02/09 ▶ | 80291TF0E01 | 715692 | |
| Jazz (2002>2008) | +/- | | ■■■ | 01/02 ▶ 09/08 | 80291SAAE01 | 698886 | |
| Jazz (2008>) | + | | ■■■ | 10/08 ▶ | 80292TF0G01 | 715692 | |
| Legend | +/- | | ■■■ | 09/06 ▶ | 80292SHJA41 | 698868 | 80292SFY003 715678 |
| Logo | +/- | | ■■■ | 12/98 ▶ 04/01 | 08R79SS0600 | 715594 | |
| Ridgeline | + | | ■■■ | 2005 ▶ | 80292SHJA41 | 698868 | |
| Stream | +/- | x2 | ■■■ | 03/01 ▶ | 80292S5A003 | 698735 | |
| HYUNDAI  | | | | | | | |
| Accent (99>2003) | + | | ■■■ | 10/99 ▶ 01/03 | 9761725000 | 715516 | |
| Accent (2003>206) | + | | ■■■ | 01/03 ▶ 06/06 | 9761725000 | 715516 | |
| Accent (2006>) | + | | ■■■ | 07/06 ▶ | 971331E000 | 715592 | |
| Carens IV | + | | ■■■ | 03/13 ▶ | 971332H001 | 715592 | |
| Ceed II | +/- | | ■■■ | 05/12 ▶ | 971332H001 | 715592 | |
| Coupé (2002>) | +/- | | ■■■ | 01/02 ▶ | 971332D000 | 715517 | |
| Elantra (2000>2003) | + | | ■■■ | 06/00 ▶ 06/03 | 971332D000 | 715517 | |
| Elantra (2003>) | + | | ■■■ | 07/03 ▶ | 971332D200 | 715591 | |
| Elantra (2006>) | + | | ■■■ | 11/06 ▶ | 971332H001 | 715592 | |
| Genesis | +/- | | ■■■ | 11/10 ▶ | 087902E200 | 715521 | |
| Getz | +/- | | ■■■ | 09/02 ▶ | 9999207019 | 715656 | |
| Getz | - | x2 | ■■■ | 09/02 ▶ | 976171C000 | 715525 | |
| Grandeur | + | | ■■■ | 11/05 ▶ | 9761037000 | 715516 | |
| Grandeur Azera | + | | ■■■ | 04/05 ▶ | 971332B010 | 715541 | |
| i 10 | + | | ■■■ | 02/08 ▶ | 9713307010 | 715524 | |
| i 20 | + | | ■■■ | 12/08 ▶ | 971331J000 | 715662 | |
| i 20 | +/- | | ■■■ | 04/10 ▶ 04/12 | 971334P000 | 715748* | |
| ix20 | +/- | | ■■■ | 10/10 ▶ | 971331P000 | 715741 | |
| i 30 | +/- | | ■■■ | 08/07 ▶ | 97133-2L000 | 715638 | |
| i30 cw | + | | ■■■ | 03/12 ▶ | 971332H001 | 715592 | |
| ix35 | +/- | | ■■■ | 01/10 ▶ | 97133-2E250 | 715740 | |
| i 40 | + | | ■■■ | 08/11 ▶ | 971332E210 | 715521 | |
| ix55 (2008>) | +/- | | ■■■ | 09/08 ▶ | 971333J100 | 715697 | |
| Matrix | +/- | | ■■■ | 05/01 ▶ | 971332D000 | 715517 | |
| Santa Fe | + | | ■■■ | 02/01 ▶ 11/04 | 9761938100 | 698888 | |
| Santa Fe | + | x2 | ■■■ | 11/04 ▶ 03/06 | 976193D100, 976193D200 | 715529 | |
| Santa Fe II | + | | ■■■ | 03/06 ▶ 01/11 | 971333K000 | 715541 | |
| Santa Fé CM10 | + | | ■■■ | 02/10 ▶ | 971332B005 | 715716 | |





















|  | AC |  |  |  | PA  OE Valeo | CA  OE Valeo | PCA  Valeo |
|--|-----|--|---|---|---|---|---|
| HYUNDAI  (.../...) | | | | | | | |
| Sonata (98>2001) | +/- | | ■■■ | 08/98 ▶ 06/01 | 9761938100 | 698888 | |
| Sonata (2001>2005) | + | x2 | ■■■ | 06/01 ▶ 02/05 | 976193D100, 976193D200 | 715529 | |
| Sonata (2005>) | +/- | | ■■■ | 03/05 ▶ | 971333K000 | 715541 | |
| Terracan (HP) (2001>) | + | | ■■■ | 01/01 ▶ | 97030H1726 | 715527 | |
| Trajeta (2000>) | + | | ■■■ | 01/00 ▶ 04/03 | 9761938100 | 698888 | |
| Trajeta (2000>) | + | x2 | ■■■ | 04/03 ▶ | 976193D100, 976193D200 | 715529 | |
| Tucson | +/- | | ■■■ | 07/04 ▶ | 971332E200 | 715521 | |
| Tucson | + |  x2 | ■■■ | 08/04 ▶ | 971332E900 | 715639 | |
| Tucson | + | | ■■■ | 07/04 ▶ | 971332E250 | 715740 | |
| Veloster | + | | ■■■ | 07/11 ▶ | 976174H900 | 715521 | |
| XG (99>2002) | +/- | | ■■■ | 01/99 ▶ 08/02 | 9761938100 | 698888 | |
| XG (2002>) | + | | ■■■ | 09/02 ▶ 03/03 | 9761938100 | 698888 | |
| XG (2002>) | + | x2 | ■■■ | 03/03 ▶ | 976193D100, 976193D200 | 715529 | |
| 140 | + | | ■■■ | 03/12 ▶ | 971334P000 | 715748* | |
| HYUNDAI  | | | | | | | |
| H1 Starex | | x2 | ■■■ | 02/08 ▶ | 976174H000 | 715669 | |
| H1 (2000>2006) | + | | ■■■ | 02/00 ▶ 10/06 | 974064A900 | 715738 | |
| H1 Mini Bus (2001>2006) | +/- | | ■■■ | 10/01 ▶ 09/06 | 974064A900 | 715738 | |
| Highway Van | +/- | | ■■■ | 03/00 ▶ 04/03 | 9761938100 | 698888 | |
| Highway Van | + | | ■■■ | 04/03 ▶ 02/04 | 976193D000 | 715529 | |
| iLoad | + | | | 10/97 ▶ 01/08 | 974064A900 | 715738 | |
| iLoad | +/- | x2 | ■■■ | 02/08 ▶ | 976174H000 | 715669 | |
| i800 | +/- | | | 10/97 ▶ 01/08 | 974064A900 | 715738 | |
| i800 | +/- | x2 | ■■■ | 02/08 ▶ | 976174H000 | 715669 | |
| INFINITI  | | | | | | | |
| FX 35 /45 | +/- | | ■■■ | 01/03 ▶ | B727A79925 | 715631 | 27277Z5000 715560 |
| G20 | + | x2 | ■■■ | 01/97 ▶ | 272747J125 | 715561 | |
| G35 | + | | ■■■ | 05/02 ▶ | B727A79925 | 715631 | 27277Z5000 715560 |
| I30 | + | x2 | | 03/00 ▶ 09/04 | | | B72003Y000 698873 |
| I35 | + | x2 | | 03/00 ▶ 09/04 | | | B72003Y000 698873 |
| QX4 | + | x2 | ■■■ | 01/97 ▶ | 272747J125 | 715561 | |
| ISUZU  | | | | | | | |
| D-Max | + | | ■■■ | 01/03 ▶ 12/06 | 8980084420 | 715718 | |
| Trooper (2000>) | +/- | x2 | ■■■ | 04/00 ▶ | 8971708040 | 715569 | |
| ISUZU  | | | | | | | |
| Rodeo | + | | ■■■ | 01/04 ▶ 12/04 | 8980084420 | 715718 | |
| IVECO  | | | | | | | |
| Campagnola | +/- | | | 12/08 ▶ | | | 2994769 716063 |

|  | AC |  |  |  | PA   | CA   | PCA  | |
|--|-----|---|---|---|---|---|--|---------------|
| IVECO  (.../...) | | | | | | | | |
| Daily (99>2006) | +/- | | ■■■■ | 05/99 ▶ 03/06 | 500314688 | 698197 | 93162491 | 698687 |
| Daily (2006>) | + | | | 04/06 ▶ | 3802821 | 715595 | 2994769 | 716063 |
| Massif | +/- | | | 03/08 ▶ | 3802821 | 715595 | 2994769 | 716063 |
| Rapido | +/- | | | 02/07 ▶ | | | 2994769 | 716063 |
| JAGUAR  | | | | | | | | |
| Sovereign | +/- | | ■■■■ | 10/02 ▶ | | | C2C6884 | 715504 |
| S-Type (98>2003) | - | | ■■■■ | 10/98 ▶ 12/03 | | | XR830254 | 715505 |
| S-Type (2004>) | + | | ■■■■ | 01/04 ▶ | | | XR830254 | 715505 |
| XF | + | | ■■■■ | 03/08 ▶ | | | C2Z6525 | 715681 |
| XJ (2002>2009) | + | | ■■■■ | 10/02 ▶ 12/09 | | | C2C6884 | 715504 |
| XJ (2010>) | + | | ■■■■ | 01/10 ▶ | | | C2Z6525 | 715681 |
| XJR (2002>2009) | +/- | | ■■■■ | 10/02 ▶ 12/09 | | | C2C6884 | 715504 |
| XJR (2010>) | + | | ■■■■ | 01/10 ▶ | | | MF145570-0380 | 715681 |
| Xk | +/- | x2 | ■■■■ | 03/06 ▶ | | | C2P2410 | 715640 |
| X-Type | + | | ■■■■ | 02/01 ▶ | C2S8619 | 698779 | | |
| X-Type | M+ | | ■■■■ | 02/01 ▶ | | | C2S8622 | 698745 |
| JEEP  | | | | | | | | |
| Cherokee II | A+ | | ■■■■ | 09/01 ▶ 07/05 | 05013595AB | 715670 | | |
| Cherokee III | + | | ■■■■ | 08/05 ▶ 02/08 | 05013595AA | 715670 | | |
| Cherokee IV | + | | ■■■■ | 03/08 ▶ | 68033193AA | 715696 | | |
| Compass | +/- | | ■■■■ | 09/06 ▶ | 5058693AA | 715735 | 5058381AA | 715537 |
| Grand Cherokee II | + | | ■■■■ | 04/99 ▶ 05/05 | 82204691 | 715670 | | |
| Grand Cherokee III | + | | ■■■■ | 06/05 ▶ | 82208300 | 715670 | | |
| Grand Cherokee (2010>) | + | | ■■■■ | 09/10 ▶ | 68079487AA | 715717 | | |
| Liberty | +/- | | ■■■■ | 03/08 ▶ | 68033193AA | 715696 | | |
| Patriot | +/- | | ■■■■ | 09/06 ▶ | 5058693AA | 715735 | 5058381AA | 715537 |
| KIA  | | | | | | | | |
| Amanti (USA) | + | | | 09/03 ▶ | 971143B100 | 698889 | | |
| Carens II (2002>2006) | + | x2 | ■■■■ | 07/02 ▶ 09/06 | 0K2FA6152X | 715522 | | |
| Carens III (2006>) | + | | ■■■■ | 09/06 ▶ | 971332E200 | 715521 | | |
| Carnival (2006>) | + | | ■■■■ | 06/06 ▶ | 971332F000 | 698895 | | |
| Cee'd | + | | ■■■■ | 01/07 ▶ | 971331H000 | 715638 | | |
| Cerato | + | | ■■■■ | 01/04 ▶ | 971332F000 | 698895 | | |
| Clarus | + | x2 | ■■■■ | 05/95 ▶ 07/01 | 0K9A46152XA | 715523 | | |
| Elan | + | x2 | ■■■■ | 01/99 ▶ | 0K2FA6152X | 715522 | | |
| Magentis | + | | ■■■■ | 02/01 ▶ 12/05 | 9761938100 | 698888 | | |
| Magentis II | + | | ■■■■ | 01/06 ▶ | 971333K000 | 715541 | | |
| Opirus | + | | | 04/03 ▶ 10/06 | 971143B100 | 698889 | | |
| Optima (2001>) | + | | ■■■■ | 02/01 ▶ 11/05 | 9761938100 | 698888 | | |
| Optima (2005>) | + | | ■■■■ | 11/05 ▶ | 971333K000 | 715541 | | |













|  | AC |  |  |  | PA  OE Valeo | CA  OE Valeo | PCA  Valeo |
|--|-----|---|---|---|---|---|---|
| KIA  (.../...) | | | | | | | |
| Picanto | + | | ■ ■ ■ ■ | 01/04 ▶ | 9713307000 | 715524 | |
| Rio (2001>2005) | + | x2 | ■ ■ ■ ■ | 07/00 ▶ 05/05 | 97619FD200 | 715523 | |
| Rio (2005>) | + | | ■ ■ ■ ■ | 06/05 ▶ | 971332E200 | 715521 | |
| Sedona (2006>) | + | | ■ ■ ■ ■ | 06/06 ▶ | 971332F000 | 698895 | |
| Sephia II | + | x2 | ■ ■ ■ ■ | 10/97 ▶ 05/01 | OK2N16152X | 715618 | |
| Shuma I | +/- | x2 | ■ ■ ■ ■ | 10/97 ▶ 05/01 | OK2N16152X | 715618 | |
| Shuma II | +/- | x2 | ■ ■ ■ ■ | 05/01 ▶ 05/04 | OK2N16152X | 715618 | |
| Sorento | +/- | | ■ ■ ■ ■ | 04/02 ▶ 04/06 | 9761938100 | 698888 | |
| Sorento (JC) | + | x2 | ■ ■ ■ ■ | 04/06 ▶ | 971332E910 | 715639 | |
| Sorento (2009>) | + | | ■ ■ ■ ■ | 05/09 ▶ | 971332F010 | 698895 | |
| Soul | + | | ■ ■ ■ ■ | 10/08 ▶ | 971332K000 | 715691 | |
| Spectra (USA) | + | x2 | ■ ■ ■ ■ | 05/01 ▶ 05/04 | OK9A56152XA | 715618 | |
| Spectra New (USA) | +/- | | ■ ■ ■ ■ | 05/04 ▶ | 971332F000 | 698895 | |
| Sportage I | + | x2 | ■ ■ ■ ■ | 04/94 ▶ 09/04 | OK9A56152XA | 715618 | |
| Sportage II | + | | ■ ■ ■ ■ | 10/04 ▶ 07/10 | 971332E200 | 715521 | |
| Sportage III | + | | ■ ■ ■ ■ | 08/10 ▶ | 971330Z000 | 715740 | |
| Venga (2010>) | + | | ■ ■ ■ ■ | 02/10 ▶ | 971331P000 | 715741 | |
| LADA  | | | | | | | |
| 110 | +/- | | ■ ■ ■ ■ | 01/95 ▶ | | | 211812202010 715682 |
| 111 | - | | ■ ■ ■ ■ | 01/95 ▶ | | | 211812202010 715682 |
| 112 | - | | ■ ■ ■ ■ | 01/95 ▶ | | | 211812202010 715682 |
| Kalina 1118 | - | | ■ ■ ■ ■ | 03/05 ▶ | 111808122010 | 715739 | |
| Kalina 1119 | +/- | | ■ ■ ■ ■ | 03/05 ▶ | 111808122010 | 715739 | |
| LAMBORGHINI  | | | | | | | |
| Gallardo | +/- | x2 | ■ ■ ■ ■ | 08/03 ▶ | 4F0819439 | 715500 | 4F0819439A 715501 |
| LANCIA  | | | | | | | |
| Dedra | + | | ■ ■ ■ ■ | 03/89 ▶ 02/98 | 71712596 | 698174 | |
| Dedra | + | | ■ ■ ■ ■ | 02/98 ▶ 09/99 | 46442422 | 698197 | 60815647 698687 |
| Delta | + | | ■ ■ ■ ■ | 03/93 ▶ 08/99 | 71712596 | 698174 | |
| Delta | + | | ■ ■ ■ ■ | 06/08 ▶ | 71736776 | 715686 | |
| Flavia | +/- | | ■ ■ ■ ■ | 06/12 ▶ | K05058693AA | 715735 | K05058381AA 715537 |
| Kappa | +/- | | ■ ■ ■ ■ | 07/96 ▶ 10/00 | | | 60814643 698688 |
| Lybra | + | | ■ ■ ■ ■ | 09/99 ▶ | 60653641 | 698197 | 60815647 698687 |
| Musa | + | w/o Plastic Frame | ■ ■ ■ ■ | 07/04 ▶ 03/11 | 46723331 | 698867 | |
| Musa | +/- | w/o Plastic Frame | ■ ■ ■ ■ | 04/11 ▶ | 46723331 | 698867 | |
| Phedra | +/- | | ■ ■ ■ ■ | 09/02 ▶ | 1484383080 | 698738 | 9655190480 715558 701013 |
| Thema | + | | ■ ■ ■ ■ | 10/88 ▶ 11/94 | 82398550 | 698199 | |
| Thema II | + | | ■ ■ ■ ■ | 10/11 ▶ | K68071668AA | 715749 | |
| Thesis | | | ■ ■ ■ ■ | 09/02 ▶ | | | 46723024 698751 |
| Y (95>2000) | + | | ■ ■ ■ ■ | 11/95 ▶ 08/00 | 46721374 | 698198 | |
| Y (2000>2003) | + | w/o Plastic Frame | ■ ■ ■ ■ | 09/00 ▶ 09/03 | 46723331 | 698867 | |

|  | AC |  |  |  | PA   | CA   | PCA  | |
|---|-----|---|---|---|---|---|--|---------------|
| LANCIA  (.../...) | | | | | | | | |
| Ypsilon (2003>2011) | + | w/o Plastic Frame | ■■■ | 10/03 ▶ 04/11 | 46723331 | 698667 | | |
| Ypsilon 2011 | + | | ■■■ | 05/11 ▶ | 51854923 | 715755 • | | |
| Zeta | | x3 | ■■■ | 10/94 ▶ 08/02 | 1475478080, 1475479080 | 715530 | | |
| LAND ROVER  | | | | | | | | |
| Discovery | + | | ■■■ | 11/04 ▶ | JKR500010 | 715518 | | |
| Discovery | M+ | | ■■■ | 11/04 ▶ | | JKR500020 | 715519 | |
| Freelander | A+ | | ■■■ | 10/97 ▶ 12/00 | JKR100200 | 698799 | | |
| Freelander | + | | ■■■ | 01/01 ▶ | JKR100280 | 698817 | | |
| Freelander | +/- | | ■■■ | 10/06 ▶ | LR000899 | 715597 | LR000901 | 715702 |
| Range Rover (94>2002) | A+ | x2 | ■■■ | 09/94 ▶ 02/02 | BTR8037 | 715598 | | |
| Range Rover (2002>2010) | +/- | | ■■■ | 03/02 ▶ 05/10 | | 698775 | JM0000010 | 698776 |
| Range Rover (2010->) | + | | ■■■ | 06/10 ▶ | | | JM0000010 | 698776 |
| Range Rover Evoque | + | | ■■■ | 03/11 ▶ | LR019192 | 715597 | LR019589 | 715702 |
| Range Rover Sport | + | | ■■■ | 05/05 ▶ | JKR500010 | 715518 | JKR500020 | 715519 |
| LDV  | | | | | | | | |
| Maxus | + | | ■■■ | 07/05 ▶ | 589150001 | 715655 | 573228900 | 698688 |
| LEXUS  | | | | | | | | |
| CT 200h (2010->) | + | | ■■■ | 12/10 ▶ | 87139YZ08 | 715620 | 8713950060 | 715730 |
| GS (97>2000) | + | | ■■■ | 08/97 ▶ 07/00 | 8713930010 | 715542 | 8850530100 | 715729 |
| GS (2000>2005) | + | | ■■■ | 07/00 ▶ 01/05 | | | 8713950030 | 715641 |
| GS (2005->) | + | | ■■■ | 04/05 ▶ | 8713930040 | 715620 | 8713950060 | 715730 |
| GX 460 | + | | ■■■ | 11/09 ▶ | 87139YZ08 | 715620 | 8713950060 | 715730 |
| IS (99>2005) | + | | ■■■ | 04/99 ▶ 11/05 | 8713948020 | 715542 | 8850530100 | 715729 |
| IS (2005->) | + | | ■■■ | 12/05 ▶ | 8713930040 | 715620 | 8713950060 | 715730 |
| LFA | + | | ■■■ | 12/10 ▶ | 87139YZ08 | 715620 | 8713950060 | 715730 |
| LS (94>2000) | + | | ■■■ | 10/94 ▶ 10/00 | 8713930010 | 715542 | 8850530100 | 715729 |
| LS (2000>2006) | + | | ■■■ | 10/00 ▶ 09/06 | | | 8713950030 | 715641 |
| LS 460 (2006->) | + | | ■■■ | 08/06 ▶ | 87139YZ08 | 715620 | 8713950060 | 715730 |
| LX 570 | +/- | | ■■■ | 11/07 ▶ | 87139YZ08 | 715620 | 8713950060 | 715730 |
| RX (97>2003) | + | | ■■■ | 08/97 ▶ 05/03 | 8713948020 | 715542 | 8850530100 | 715729 |
| RX 300 | + | | ■■■ | 06/03 ▶ | | | 8713933010 | 715619 |
| RX 350 | + | | ■■■ | 06/03 ▶ | | | 8713933010 | 715619 |
| RX 400 | + | | ■■■ | 06/03 ▶ | | | 8713933010 | 715619 |
| RX350/450H | + | | ■■■ | 03/09 ▶ | 87139YZ08 | 715620 | 8713950060 | 715730 |
| SC 430 | + | | ■■■ | 08/01 ▶ | | | 8713950030 | 715641 |
| MASERATI  | | | | | | | | |
| 3200GT | + | | ■■■ | 10/98 ▶ 03/02 | | | 573228900 | 698688 |
| Coupe/ Spider 4200 | + | | ■■■ | 10/01 ▶ | | | 2108301118 | 698772 |
| MAYBACH  | | | | | | | | |
| 57/62 (240) | + | 100% Act. carbon x2 | ■■■ | 09/02 ▶ | | | 2108301118 | 698772 |

|  | | AC |  |  |  | PA  OE Valeo | CA  OE Valeo | PCA  Valeo |
|--|-----|---|---|---|---|---|---|---|
| MAYBACH  (.../...) | | | | | | | | |
| 57/62 (240) | A+ | x2 | ■■■ | 09/02 ▶ | 2108300018 | 715531 | | |
| MAZDA  | | | | | | | | |
| 2 (2003>2007) | A+ | | ■■■ | 03/03 ▶ 09/07 | GJ6A61P11A | 698870 | GJ6B61P11 | 715679 |
| 2 (2007>2010) | +/- | x2 | ■■■ | 10/07 ▶ 07/10 | D65161J6X | 715642 | | |
| 2 (2010>) | +/- | x2 | ■■■ | 08/10 ▶ | D65161J6X | 715642 | | |
| 3 (2003>2008) | +/- | x2 | ■■■ | 06/03 ▶ 11/08 | BP4K61J6X | 698892 | | |
| 3 (2008>) | + | x2 | ■■■ | 12/08 ▶ | BBP261J6X | 715726 | | |
| 5 (2005>2010) | +/- | x2 | ■■■ | 04/05 ▶ 05/10 | CC2961J6X | 698892 | | |
| 5 (2010>) | + | x2 | ■■■ | 06/10 ▶ | CC6461J6X | 698892 | | |
| 6 (2002>2010) | + | | ■■■ | 06/02 ▶ 04/10 | GJ6A61P11A | 698870 | GJ6B61P11 | 715679 |
| 6 (2010>) | +/- | | ■■■ | 05/10 ▶ | GS1D61P11 | 698870 | | |
| 121 (JA/JB) (96>) | +/- | | ■■■ | 03/96 ▶ | 1E061J6X | 698201 | 410077732 | 715617 |
| 323 (BA) | +/- | x3 | ■■■ | 08/94 ▶ 09/98 | BC5D61J6X | 715664 | | |
| 323 (BJ) (98>2000) | + | | ■■■ | 08/98 ▶ 09/00 | GE7B61J6XA | 715599 | | |
| 323 (BJ) (98>2000) | - | x2 | ■■■ | 08/98 ▶ 09/00 | GE6T61J6X | 698891 | CB1261J6X | 698890 |
| 323 (BJ) (2000>2003) | + | | ■■■ | 10/00 ▶ 10/03 | GE7B61J6XA | 715599 | | |
| 323 (BJ) (2000>2003) | - | x2 | ■■■ | 10/00 ▶ 10/03 | GE6T61J6X | 698891 | CB1261J6X | 698890 |
| 626 (GF) (99>2002) | + | x2 | ■■■ | 10/99 ▶ 05/02 | GE6T61J6X | 698891 | CB1261J6X | 698890 |
| 626 (GF) (99>2002) | + | | ■■■ | 10/99 ▶ 05/02 | GE7B61J6XA | 715599 | | |
| 626 (GW) (97>99) | - | x2 | ■■■ | 11/97 ▶ 09/99 | GE6T61J6X | 698891 | | |
| 626 (GW) (99>2002) | + | | ■■■ | 10/99 ▶ 05/02 | GE7B61J6XA | 715599 | | |
| BT-50 II | - | | ■■■ | 11/11 ▶ | UCY061P11 | 715745 | | |
| CX7 | +/- | | ■■■ | 01/07 ▶ | GJ6A61P11A | 698870 | GJ6B61P11 | 715679 |
| Demio | +/- | x2 | ■■■ | 05/98 ▶ 03/03 | DC2161J6X | 715576 | | |
| Demio | - | | ■■■ | 05/98 ▶ 03/03 | | | DC4561J6X | 715750* |
| MPV | + | x2 | ■■■ | 09/99 ▶ | LDY461J6X | 715574 | LDY361J6X | 715728 |
| Premacy (99>2001) | +/- | x2 | ■■■ | 06/99 ▶ 06/01 | GE6T61J6X | 698891 | CB1261J6X | 698890 |
| Premacy (99>2001) | + | | ■■■ | 07/99 ▶ | GE7B61J6XA | 715599 | | |
| Premacy (2001>) | - | x2 | ■■■ | 07/01 ▶ | GE6T61J6X | 698891 | CB1261J6X | 698890 |
| RX-8 | + | x2 | ■■■ | 02/03 ▶ | LDY461J6X | 715574 | LDY361J6X | 715728 |
| Tribute (2000>) | + | | ■■■ | 01/00 ▶ | EC1361J6XA | 698893 | | |
| Xedos 6 (CA) | + | x2 | | 08/93 ▶ 01/00 | TA0561J6X | 715657 | | |
| Xedos 9 (TA) | + | x2 | | 08/93 ▶ 01/00 | TA0561J6X | 715657 | | |
| MERCEDES  | | | | | | | | |
| A Class (168) (97>) | + | | ■■■ | 05/97 ▶ 06/04 | 1688300018 | 698475 | 1688300818 | 698744 |
| A Class (169) (2004>) | +/- | | ■■■ | 07/04 ▶ | 1698300118 | 715506 | 1698300218 | 715507 |
| A Class (169) (2004>) | +/- | | ■■■ | 07/04 ▶ | | | 1698300218 | 715507 |
| B Class | A+ | | ■■■ | 03/05 ▶ | 1698300118 | 715506 | 1698300218 | 715507 |
| B Class | +/- | | ■■■ | 03/05 ▶ | | | 1698300218 | 715507 |
| C Class (202) | A+ | | ■■■ | 03/93 ▶ 02/01 | 2028300018 | 698169 | 2108300818 | 698697 |
| C Class (202) | +/- |  | ■■■ | 03/93 ▶ 02/01 | 2028300318 | 698169 | 2108300818 | 698697 |













|  | AC |  |  |  | PA  | CA  | PCA  |
|---|-----|---|---|---|---|---|--|
| MERCEDES  (.../...) | | | | | | | |
| C Class (203) | +/- | 100% Act. Carbon x2 | ■■■ | 04/00 ▶ | | 2038300518 | 698742 |
| C Class (203) | +/- |  | ■■■ | 04/00 ▶ | 2038300118 | 698700 | 2038300918 698743 |
| C Class (203) | +/- |  | ■■■ | 04/00 ▶ | 2038300218 | 698701 | |
| C Class (204) | +/- | | ■■■ | 04/07 ▶ 12/10 | | 2048300018 | 715600 |
| CL Class (215) | +/- |  100% Act. Carbon x2 | ■■■ | 08/99 ▶ | 2108301018 | 715531 | 2108301118 698772 |
| CL Class (216) (2006>) | A+ | x2 | ■■■ | 05/06 ▶ | | 2218300018 | 715643 |
| CLC (203) (2008>) | + | | ■■■ | 03/08 ▶ | | 2038300918 | 698743 |
| CLC (203) (2008>) | +/- | x2 | ■■■ | 03/08 ▶ | | 2038302118 | 698742 |
| CLK (208) | A+ |  | ■■■ | 06/97 ▶ 02/02 | 2028300018 | 698169 | 2108300818 698697 |
| CLK (208) | +/- |  | ■■■ | 06/97 ▶ 02/02 | 2028300318 | 698169 | 2108300818 698697 |
| CLK (209) | + |  | ■■■ | 03/02 ▶ | 2038300118 | 698700 | 2038300918 698743 |
| CLK (209) | + |  | ■■■ | 03/02 ▶ | 2038300218 | 698701 | |
| CLS (219) | A+ | | ■■■ | 07/04 ▶ | 2118300218 | 698702 | 2118300018 698741 |
| CLS (219) | + | 100% Act. Carbon x2 | ■■■ | 07/04 ▶ | | 2118300818 | 698740 |
| E Class (124) | A+ |  | ■■■ | 07/93 ▶ 02/96 | 1248350047 | 715684 | |
| E Class (210) | +/- |  | ■■■ | 04/95 ▶ 03/03 | 2028300018 | 698169 | 2108300818 698697 |
| E Class (210) | +/- |  | ■■■ | 04/95 ▶ 03/03 | 2028300318 | 698169 | 2108300818 698697 |
| E Class (210) | +/- | 100% Act. Carbon x2 | ■■■ | 04/95 ▶ 03/03 | | 2108301118 | 698772 |
| E Class (210) | A+ | x2 | ■■■ | 04/95 ▶ 03/03 | 2108300018 | 715531 | |
| E Class (210) | A+ | x2 | ■■■ | 04/95 ▶ 03/03 | 2108301018 | 715531 | |
| E Class (211) | A+ | | ■■■ | 03/02 ▶ | 2118300218 | 698702 | 2118300018 698741 |
| E Class (211) | +/- | 100% Act. Carbon x2 | ■■■ | 03/02 ▶ | | 2118300818 | 698740 |
| E Class (211) | A+ | | ■■■ | 03/02 ▶ | 2118300218 | 698702 | |
| E Class (212) | M+ | | ■■■ | 03/09 ▶ | | 2128300018 | 715600 |
| G Class (W461/463) | +/- | | ■■■ | 03/98 ▶ | | 4638300018 | 698739 701009 |
| GL Class (164) | + | x2 | ■■■ | 01/06 ▶ | | 1648300218 | 715544 |
| GL Class (166) | + | | ■■■ | 11/12 ▶ | 1668300218 | 715751 • | |
| GLK | + | | ■■■ | 07/08 ▶ | | 2128300018 | 715600 |
| M Class (163) | +/- | | ■■■ | 05/97 ▶ | 1638350247 | 698777 | |
| M Class (163) | +/- | | ■■■ | 03/98 ▶ | 1638350247 | 698777 | 1638350047 698778 |
| M Class (164) | A+ | x2 | ■■■ | 07/05 ▶ | | 1648300218 | 715544 |
| ML (164) (2008>) | + | x2 | ■■■ | 04/08 ▶ | | 1648300218 | 715544 |
| ML (166) | + | | ■■■ | 07/11 ▶ | 1668300218 | 715751 • | |
| R Class (251) | + | x2 | ■■■ | 10/05 ▶ | | 1648300218 | 715544 |
| S Class (124) | + | | ■■■ | 12/84 ▶ 06/93 | 1248300118 | 698704 | |
| S Class (140) | + |  | ■■■ | 03/91 ▶ 07/99 | 1408350047 | 698704 | |
| S Class (140) | + | PREFILTER | ■■■ | 03/91 ▶ 07/99 | | 698797 | |
| S Class (140) | + |  | ■■■ | 03/91 ▶ 07/99 | 1408350547 | 698706 | 1408350447 698705 |
| S Class (220) | A+ | | ■■■ | 09/98 ▶ 08/05 | 2108300018 | 698169 | |
| S Class (220) | + | 100% Act. Carbon x2 | ■■■ | 09/98 ▶ 08/05 | | 2108301118 | 698772 |









|  | AC |  |  |  | PA  OE Valeo | CA  OE Valeo | PCA  Valeo | |
|---|-----|---|---|---|---|---|---|---------------|
| MERCEDES  (.../...) | | | | | | | | |
| S Class (220) | A+ | x2 | ■■■ | 09/98 ▶ | 2108300018 | 715531 | | |
| S Class (221) | A+ | x2 | ■■■ | 09/05 ▶ | | | 2218300018 | 715643 |
| SL (R230) | + | x2 | ■■■ | 10/01 ▶ | | | 2308300418 | 715621 |
| SLK (R170) | + |  | ■■■ | 08/96 ▶ 12/03 | 2028300018 | 698169 | 2108300818 | 698697 |
| SLK (R170) | +/- |  | ■■■ | 08/96 ▶ 12/03 | 2028300318 | 698169 | 2108300818 | 698697 |
| SLK (R171) | +/- | | ■■■ | 01/04 ▶ | | | 1718300418 | 715508 |
| SLR (R199) | + | x2 | ■■■ | 04/04 ▶ | | | 2308300418 | 715621 |
| SLS (C197) | + | | ■■■ | 03/10 ▶ | | | 2128300218 | 715600 |
| Vaneo (414) | +/- | | ■■■ | 10/01 ▶ | 1688300018 | 698475 | 1688300818 | 698744 |
| V Class (638) | +/- | | ■■■ | 10/96 ▶ 12/02 | 0018353047 | 715577 | | |
| MERCEDES  | | | | | | | | |
| Sprinter I | + | | ■■■ | 02/95 ▶ 05/06 | 9018300018 | 698840 | 9018300418 | 716023 |
| Sprinter II | +/- | | ■■■ | 04/06 ▶ | | | 9068300318 | 715602 |
| Sprinter II | A+ | | ■■■ | 04/06 ▶ | 9068300218 | 715601 | | |
| Viano | A+ | | ■■■ | 01/03 ▶ | 6398350247 | 698871 | | |
| Viano | M+ | | ■■■ | 09/03 ▶ | 6398350247 | 698871 | 6398350347 | 698872 |
| Vito (638) | +/- | | ■■■ | 11/95 ▶ 09/03 | 6398350047 | 715577 | | |
| Vito (639) | +/- | | ■■■ | 09/03 ▶ | | | 6398350347 | 698872 |
| Vito (639) | A+ | | ■■■ | 01/03 ▶ | 6398350247 | 698871 | | |
| Vito (639) | M+ | | ■■■ | 09/03 ▶ | 6398350247 | 698871 | 6398350347 | 698872 |
| MG  | | | | | | | | |
| MG ZR | +/- | | ■■■ | 06/01 ▶ | JKR100020 | 698196 | | |
| MG ZS | + |  | ■■■ | 07/01 ▶ | JKR100220 | 698819 | | |
| MG ZS | - |  | ■■■ | 07/01 ▶ | JKR100020 | 698196 | | |
| MG ZT | + | | ■■■ | 06/01 ▶ | JKR100183 | 698879 | JKR000040 | 698880 |
| MINI  | | | | | | | | |
| Mini | + | | ■■■ | 09/01 ▶ | 64311496710 | 698724 | 64311496711 | 698725 |
| Mini (2006>) | +/- | | ■■■ | 11/06 ▶ | 64319127516 | 715585 | 64319127515 | 715586 |
| Mini 2 LCI (R56/57) (2009>) | A+ | | ■■■ | 03/09 ▶ | 64319127516 | 715585 | 64319127515 | 715586 |
| Mini 2 LCI (R56/57) (2009>) | +/- | | ■■■ | 03/09 ▶ | 64319127516 | 715585 | 64319127515 | 715586 |
| Mini Coupé (2011>) | +/- | | ■■■ | 09/11 ▶ | 64319127516 | 715585 | 64319127515 | 715586 |
| Mini LCI Clubman (R55) (2009>) | +/- | | ■■■ | 03/09 ▶ | 64319127516 | 715585 | 64319127515 | 715586 |
| Mini LCI Clubman (R55) (2009>) | +/- | | ■■■ | 03/09 ▶ | 64319127516 | 715585 | 64319127515 | 715586 |
| Mini Countryman (2010>) | +/- | | ■■■ | 08/10 ▶ | 64319127516 | 715585 | 64319127515 | 715586 |
| MINI Roadster (R59) | +/- | | ■■■ | 03/12 ▶ | 64319127516 | 715585 | 64319127515 | 715586 |
| MITSUBISHI  | | | | | | | | |
| Airtrek I | +/- | | ■■■ | 06/01 ▶ 06/05 | | | MR398288 | 715546 |
| Airtrek II | + | | ■■■ | 06/05 ▶ | 7803A004 | 715631 | 7803A005 | 715623 |
| ASX | +/- | | ■■■ | 04/10 ▶ | 7803A004 | 715631 | 7803A005 | 715623 |

|  | AC |  |  |  | PA   | CA   | PCA  |
|---|-----|---|---|---|---|---|--|
| MITSUBISHI  (.../...) | | | | | | | |
| Carisma | +/- | | ■■■ | 07/95 ▶ 08/00 | MZ311916 | 715688 | |
| Carisma | - | x2 | ■■■ | 09/00 ▶ | MZ311917 | 715548 | |
| Colt V (CJ) | + | | ■■■ | 05/96 ▶ 07/04 | MR227823 | 715543 | |
| Colt VI (2004>) | + | | ■■■ | 05/04 ▶ | MR958016 | 715603 | MR958017 698802 |
| Galant (92>96) | + | | ■■■ | 11/92 ▶ 09/96 | | | MR958017 698802 |
| Galant (1996>) | + | | ■■■ | 09/96 ▶ | MR315876 | 715528 | |
| Grandis | + | | ■■■ | 04/04 ▶ | | | MR398288 715546 |
| Lancer VI (CK1) | + | | ■■■ | 12/95 ▶ 08/03 | MR227823 | 715543 | |
| Lancer VII (GS) | + | | ■■■ | 09/03 ▶ | | | MR398288 715546 |
| Lancer VIII | + | | ■■■ | 10/07 ▶ | 7803A004 | 715631 | 7803A043 715623 |
| Lancer IX | +/- | | ■■■ | ▶ | | | 7803A005 715623 |
| L200 | +/- | | ■■■ | 01/00 ▶ 04/06 | MR227823 | 715543 | |
| Montero II | + | | | 12/90 ▶ 04/00 | | | MR500058 715509 |
| Montero III | + | | | 04/02 ▶ 02/07 | | | MR500058 715509 |
| Montero IV | + | | | 02/07 ▶ | | | 7803A028 715509 |
| Outlander I | + | | ■■■ | 05/03 ▶ 02/07 | | | MR398288 715546 |
| Outlander II | + | | ■■■ | 03/07 ▶ | 7803A004 | 715631 | 7803A005 715623 |
| Outlander III | +/- | | ■■■ | 03/07 ▶ | 7803A004 | 715631 | 7803A005 715623 |
| Pajero II | +/- | | | 12/90 ▶ 02/00 | | | MR500058 715509 |
| Pajero III (2000>) | + |  | | 02/00 ▶ 02/07 | | | MR500058 715509 |
| Pajero III (2000>) | + |  | | 02/00 ▶ | | | 7803A027 715622 |
| Pajero IV | + | | | 02/07 ▶ | | | 7803A028 715509 |
| Pajero Pinin (99>) | + | x2 | | 07/99 ▶ | XR315172 | 715545 | |
| Shogun 4 (2006>) | + | | | 09/06 ▶ | | | 7803A027 715622 |
| Space Star | +/- | x2 | ■■■ | 12/98 ▶ 1999 | MR460201 | 715548 | |
| Space Star | + | | ■■■ | 1999 ▶ | MR262425 | 715688 | |
| Space Runner | - | | | 08/99 ▶ | MR360889 | 715547 | |
| Space Wagon | + | | | 10/98 ▶ | MR360889 | 715547 | |
| NISSAN  | | | | | | | |
| Almera (95>2000) | + | x2 | ■■■ | 07/95 ▶ 01/00 | 272751N626 | 715575 | |
| Almera (2000>2003) | A+ | | ■■■ | 02/00 ▶ 01/03 | 27891BM401 | 698734 | |
| Almera (2003>) | + | | ■■■ | 02/03 ▶ | 27891BM401 | 698734 | |
| Almera Tino (2003>) | + | | ■■■ | 02/03 ▶ | 27891BM402 | 698734 | |
| Altima | + | | ■■■ | 01/02 ▶ | 27277CL025H | 715631 | 27277Z5000 715560 |
| Cube | + | | ■■■ | 08/09 ▶ | 278911FC0A | 715709 | |
| Dualis | +/- | | ■■■ | 02/07 ▶ | 27277EN025 | 715559 | 701028* |
| Frontier | + | x2 | ■■■ | 07/05 ▶ | 27274EA000 | 715520 | |
| Juke | + | | ■■■ | 07/10 ▶ | 272771KA0A | 715721 | 272774936R 715722 701025* |
| Leaf | + | | ■■■ | 12/10 ▶ | 278911FC0A | 715709 | |
| Maxima QX (A33) | +/- | x2 | | 01/00 ▶ | | | 272773Y525 698873 |
| Maxima VI | + | | ■■■ | 04/04 ▶ 05/06 | 27277CL025H | 715631 | 27277Z5000 715560 |











|  | AC |  |  |  | PA  OE Valeo | CA  OE Valeo | PCA  Valeo |
|---|-----|---|---|---|---|---|---|
| NISSAN  (.../...) | | | | | | | |
| Micra (K11) | + | | ■■■ | 10/96 ▶ 02/03 | 278936F600 | 715549 | |
| Micra (K12) | + | | ■■■ | 01/03 ▶ 03/10 | 27891AX010 | 698753 | |
| Micra (2010>) | +/- | | ■■■ | 04/10 ▶ | 272771HE0E | 715706 | 272771HE0E 715756• 701024• |
| Murano | +/- | | ■■■ | 04/03 ▶ 05/08 | 27277CL025H | 715631 | 27277Z5000 715560 |
| Murano (Z51) (2008>) | + | | ■■■ | 06/08 ▶ | B7277JN20A | 715703 | |
| Navarra | +/- | x2 | ■■■ | 07/05 ▶ | 27274EA000 | 715520 | |
| Note | + | | ■■■ | 09/05 ▶ | 27891AX010 | 698753 | |
| Pathfinder (R50) (1997>) | +/- | x2 | ■■■ | 09/97 ▶ 03/05 | 272747J125 | 715561 | |
| Pathfinder (R51) (2005>) | + | x2 | ■■■ | 04/05 ▶ | 27274EA000 | 715520 | |
| Patrol GR (Y61) | + | x2 | ■■■ | 06/97 ▶ 07/04 | 272747J125 | 715561 | |
| Pixo | + | | ■■■ | 06/09 ▶ | 278914A00C | 715694 | |
| Primera (P11) (96>2002) | +/- | | ■■■ | 06/96 ▶ 09/99 | 278932F900 | 698707 | |
| Primera (P11) (96>2002) | + | | ■■■ | 09/99 ▶ 02/02 | 278932F900 | 698707 | |
| Primera (P12) | + | | ■■■ | 03/02 ▶ | 27891BM401 | 698734 | |
| Qashqai (2007>2010) | + | | ■■■ | 03/07 ▶ 01/10 | 27277EN025 | 715559 | 27277JD10A 715732 701028• |
| Qashqai (2010>) | + | | ■■■ | 02/10 ▶ | 27277EN000 | 715559 | 701028• |
| Rogue | + | | ■■■ | 03/08 ▶ | 27277EN025 | 715559 | 701028• |
| Teana | + | | ■■■ | 02/08 ▶ | B7277JN20A | 715703 | |
| Terrano II (R20) (93>2001) | +/- | | ■■■ | 03/93 ▶ 02/04 | 278939F500 | 698707 | |
| Tiida (C11X) (2007>) | + | | ■■■ | 03/07 ▶ | 27891EL00A | 715708 | |
| Xterra | +/- | x2 | ■■■ | 07/05 ▶ | 999M1D4005 | 715520 | |
| X-Trail (2001>2007) | + | | ■■■ | 06/01 ▶ 02/07 | B727A79925 | 715631 | 27277Z5000 715560 |
| X-Trail (2007>) | + | | ■■■ | 03/07 ▶ | 27277EN025 | 715559 | 701028• |
| NISSAN  | | | | | | | |
| Primastar | + | | ■■■ | 09/02 ▶ | 2729800QAA | 715513 | |
| Kubistar | +/- | | ■■■ | 09/03 ▶ | B729800QAA | 698255 | 7711228912 715538 701018 |
| Kubistar | + | | ■■■ | 09/03 ▶ | 2729800QAA | 715513 | |
| NV200 (2009>) | - | | ■■■ | 08/09 ▶ | 27891EL00A | 715708 | |
| NV400 | +/- | x2 | ■■■ | 01/11 ▶ | 7701209837 | 715649 | |
| OPEL  | | | | | | | |
| Adam | +/- | | ■■■ | 01/13 ▶ | 6808622 | 715552 | 6808623 715553 701003 |
| Agila | +/- | | ■■■ | 03/00 ▶ 01/08 | 4705463 | 698773 | |
| Agila | +/- | | ■■■ | 02/08 ▶ | 4710210 | 715644 | |
| Ampera | +/- | | ■■■ | 06/11 ▶ | | | 1808246 715659 |
| Antara | +/- | | ■■■ | 06/06 ▶ | 4803883 | 715654 | |
| Astra F (91>98) | +/- | | ■■■ | 03/91 ▶ 01/98 | 6808600 | 698165 | 1718044 715632 |
| Astra G (98>2004) | +/- | Behr | ■■■ | 02/98 ▶ 02/04 | 6808611 | 698663 | 1718042 698708 701008 |
| Astra G (98>2004) | + | Delphi | ■■■ | 02/98 ▶ 02/04 | 1808610 | 698662 | 1718046 698875 |
| Astra H (2004>) | +/- | | ■■■ | 03/04 ▶ | 6808606 | 698874 | 6808607 698875 |
| Astra J | +/- | | ■■■ | 11/09 ▶ | 1808524 | 715658 | 1808246 715659 |
| Calibra | +/- | | ■■■ | 09/89 ▶ 07/97 | 6808600 | 698165 | 1718044 715632 |

|  | AC |  |  |  | PA   | CA   | PCA  | |
|---|-----|---|---|---|---|---|--|-----------------------------|
| OPEL  (.../...) | | | | | | | | |
| Corsa B (93>2000) | +/- | | ■■■■ | 03/93 ▶ 08/00 | 1808604 | 698166 | | |
| Corsa B (93>2000) | - | | ■■■■ | 03/93 ▶ 08/00 | 6808600 | 698165 | 1718044 | 715632 |
| Corsa B (93>2000) | + |  | ■■■■ | 03/93 ▶ 08/00 | 1808606 | 715645 | | |
| Corsa C (2000>2003) | + | | ■■■■ | 09/00 ▶ 08/03 | 1808619 | 698711 | 1808624 | 698710 701010 |
| Corsa C (2003>2006) | +/- | | ■■■■ | 09/03 ▶ | 6808601 | 698711 | 1808624 | 698710 701010 |
| Corsa D (2006>) | +/- | | ■■■■ | 07/06 ▶ | 6808622 | 715552 | 6808623 | 715553 701003 |
| Insignia | +/- | | ■■■■ | 01/09 ▶ | 1808524 | 715658 | 1808246 | 715659 |
| Meriva (2003>2010) | + | | ■■■■ | 05/03 ▶ 04/10 | 6808604 | 698876 | 6808605 | 698877 |
| Meriva (2010>) | +/- | | ■■■■ | 05/10 ▶ | 1808524 | 715658 | 1808246 | 715659 |
| Meriva B | +/- | | ■■■■ | 05/10 ▶ | | | 1808020 | 715752* |
| Mokka | | | ■■■■ | 12/12 ▶ | | | 1808246 | 715659 |
| Monterey | +/- | x2 | ■■■■ | 04/98 ▶ 08/99 | 1808613 | 715659 | | |
| Omega A (86>1994) | + | | ■■■■ | 09/86 ▶ 05/94 | 1808605 | 698167 | | |
| Omega B (94>2003) | +/- | | ■■■■ | 03/94 ▶ 07/03 | 1808605 | 698167 | 1808614 | 698746 |
| Signum | +/- | | ■■■■ | 06/03 ▶ | 6808601 | 698711 | 1808624 | 698710 701010 |
| Sintra | +/- | x2 | ■■■■ | 03/96 ▶ 12/99 | 1808609 | 698712 | | |
| Tigra (94>2003) | +/- | | ■■■■ | 10/94 ▶ 01/01 | 1808604 | 698166 | | |
| Tigra (94>2003) | - | | ■■■■ | 10/94 ▶ 01/01 | 6808600 | 698165 | 1718044 | 715632 |
| Tigra Twin Top (2004>) | + | | ■■■■ | 06/04 ▶ | 6808601 | 698711 | 1808624 | 698710 701010 |
| Vectra B (95>99) | +/- | | ■■■■ | 10/95 ▶ 01/99 | 1808607 | 698202 | | |
| Vectra B (95>2002) | +/- | | ■■■■ | 10/95 ▶ 04/02 | 1808607 | 698202 | 1808608 | 715675 |
| Vectra C (2002>) | +/- | | ■■■■ | 04/02 ▶ | 6808601 | 698711 | 1808624 | 698710 701010 |
| Zafira (98>2005) | +/- | | ■■■■ | 01/99 ▶ 06/05 | 6808611 | 698663 | 1718042 | 698708 701008 |
| Zafira II (2005>) | +/- | | ■■■■ | 07/05 ▶ 09/11 | 6808611 | 698663 | 1718042 | 698708 701008 |
| Zafira III (2011>) | + | | ■■■■ | 10/11 ▶ | | | 1808246 | 715659 |
| OPEL  | | | | | | | | |
| Combo (93>2001) | +/- | | ■■■■ | 03/93 ▶ 09/01 | 1808604 | 698166 | | |
| Combo (93>2001) | - | | ■■■■ | 03/93 ▶ 09/01 | 6808600 | 698165 | 1718044 | 715632 |
| Combo (2001>) | + | | ■■■■ | 10/01 ▶ | 6808601 | 698711 | | |
| Combo (2001>) | - | | ■■■■ | 10/01 ▶ | | | 1808624 | 698710 701010 |
| Combo (2012>) | + | | ■■■■ | 02/12 ▶ | 6808622 | 715552 | 6808623 | 715553 701003 |
| Movano | +/- | | ■■■■ | 07/98 ▶ | 4408840 | 715513 | | |
| Vivaro | +/- | | ■■■■ | 05/01 ▶ | 4408840 | 715513 | | |
| PEUGEOT  | | | | | | | | |
| 106 | +/- | | ■■■■ | 09/91 ▶ 07/03 | 644191 | 715589 | | |
| 107 | + | | ■■■■ | 06/05 ▶ | 6479A5 | 715515 | | |
| 1007 | + | | ■■■■ | 04/05 ▶ | 6447KK | 698664 | | |
| 1007 | - | | ■■■■ | 04/05 ▶ | | | 6447KL | 698714 701014 |
| 1007 | A+ | | ■■■■ | 04/05 ▶ | 6447KK | 698664 | | |
| 206 | M+ | | ■■■■ | 09/98 ▶ | 6447AZ | 698488 | 6447PE | 698749 |
| 206 | + | | ■■■■ | 09/98 ▶ | 6447AZ | 698488 | | |

|  | AC |  |  |  | PA  OE Valeo | CA  OE Valeo | PCA  Valeo | | |
|--|-----|--|---|---|---|---|---|--------|--------|
| PEUGEOT  (.../...) | | | | | | | | | |
| 206+ | - | | ■ ■ ■ | 03/09 ▶ | 6447AZ | 698488 | | | |
| 207 | +/- | x2 | ■ ■ ■ | 03/06 ▶ | 6447VY | 715556 | 6447VX | 715557 | 701007 |
| 207 | M+ | x2 | ■ ■ ■ | 03/06 ▶ | | | 6447VX | 715557 | 701007 |
| 208 | A+ | x2 | ■ ■ ■ | 03/12 ▶ | 6447WY | 715556 | 6447VX | 715557 | 701007 |
| 208 | M+ | x2 | ■ ■ ■ | 03/12 ▶ | 6447WY | 715556 | 6447VX | 715557 | 701007 |
| 208 | - | x2 | ■ ■ ■ | 03/12 ▶ | | | 6447VX | 715557 | 701007 |
| 2008 | A+ |  x2 | ■ ■ ■ | 04/13 ▶ | 1609428080 | 715556 | 6447VX | 715557 | 701007 |
| 306 | +/- | | ■ ■ ■ | 05/93 ▶ | 002484 | 715646 | | | |
| 307 (2001>2004) | + | | ■ ■ ■ | 03/01 ▶ 05/05 | 6447KK | 698664 | | | |
| 307 (2001>2004) | - | | ■ ■ ■ | 03/01 ▶ 05/05 | | | 6447KL | 698714 | 701014 |
| 307 (2001>2004) | A+ | | ■ ■ ■ | 03/01 ▶ 05/05 | 6447KK | 698664 | | | |
| 307 (2005>) | M+ | | ■ ■ ■ | 06/05 ▶ | 6447KK | 698664 | 6447KL | 698714 | 701014 |
| 307 (2005>) | +/- | | ■ ■ ■ | 06/05 ▶ | | | 6447KL | 698714 | 701014 |
| 308 | A+ | | ■ ■ ■ | 09/07 ▶ | 6447KK | 698664 | 6447KL | 698714 | 701014 |
| 3008 | + | x2 | ■ ■ ■ | 06/09 ▶ | 6447XF | 715554 | 6447XG | 715555 | |
| 405 | +/- | | ■ ■ ■ | 07/92 ▶ 10/96 | 644793 | 698235 | | | |
| 406 (95>99) | + | | ■ ■ ■ | 10/95 ▶ 03/99 | 6447S5 | 698203 | | | |
| 406 (95>99) | - | | ■ ■ ■ | 10/95 ▶ 03/99 | 6447S5 | 698203 | 6447PG | 698748 | |
| 406 (99>) | + | | ■ ■ ■ | 03/99 ▶ 10/04 | 6447S5 | 698203 | 6447PG | 698748 | |
| 407 | + | | ■ ■ ■ | 04/04 ▶ 03/08 | 647904 | 715570 | 6447RG | 698884 | 701002 |
| 407 | +/- | | ■ ■ ■ | 04/08 ▶ | | | 647945 | 715635 | |
| 407 Coupé | + | | ■ ■ ■ | 10/05 ▶ | 647904 | 715570 | 6447RG | 698884 | 701002 |
| 4007 | + | | ■ ■ ■ | 07/07 ▶ | 6447ZX | 715631 | 6447ZX | 715623 | |
| 4008 | + | | ■ ■ ■ | 04/12 ▶ | 6447ZY | 715631 | 7803A005 | 715623 | |
| 508 | +/- | | ■ ■ ■ | 01/11 ▶ | | | 6479K9 | 715673 | 701000 |
| 5008 | + | x2 | ■ ■ ■ | 06/09 ▶ | 6447XF | 715554 | 6447XG | 715555 | |
| 607 (2000>2004) | +/- | | ■ ■ ■ | 05/00 ▶ 09/04 | | | 6447GW | 698713 | |
| 607 (2004>) | + | | ■ ■ ■ | 10/04 ▶ | | | 6447GW | 698713 | |
| 806 (94>98) | + | x3 | ■ ■ ■ | 07/94 ▶ 09/98 | 6447P2, 6447P3 | 715530 | | | |
| 806 (98>2002) | +/- | x3 | ■ ■ ■ | 10/98 ▶ 05/02 | 6447P2, 6447P3 | 715530 | | | |
| 807 | +/- | | ■ ■ ■ | 06/02 ▶ | 6447LY | 698738 | 6447TA | 715558 | 701013 |
| RCZ | + | | ■ ■ ■ | 05/10 ▶ | | | 647975 | 698714 | 701014 |
| PEUGEOT  | | | | | | | | | |
| Bipper | +/- |  | ■ ■ ■ | 02/08 ▶ | 647963 | 715616 | | | |
| Bipper | +/- |  | ■ ■ ■ | 07/05 ▶ | 647984 | 715552 | | | |
| Boxer (94>2006) | +/- | | ■ ■ ■ | 02/94 ▶ 06/06 | 6447SY | 698858 | | | |
| Boxer (2006>) | +/- | | ■ ■ ■ | 07/06 ▶ | 6447YA | 715636 | | | |
| Expert (95>2003) | +/- | x3 | ■ ■ ■ | 07/95 ▶ 12/03 | 6447P2, 6447P3 | 715530 | | | |
| Expert (2004>2006) | + | | ■ ■ ■ | 01/04 ▶ 12/06 | 6447LY | 698738 | 6447TA | 715558 | 701013 |













|  | AC |  |  |  | PA   | CA   | PCA   | |
|--|-----|---|---|---|--|--|---|----------------|
| PEUGEOT  (.../...) | | | | | | | | |
| Expert (2007>) | + | | ■■■ | 01/07 ▶ | 6447YL | 715614 | 6447YJ | 715613 |
| Partner (96>2002) | +/- | | ■■■ | 06/96 ▶ 12/00 | 6447Z5 | 698146 | | |
| Partner (96>2002) | + | | ■■■ | 12/00 ▶ 11/02 | 6447KR | 698657 | | |
| Partner (2002>) | + | | ■■■ | 11/02 ▶ | 6447KR | 698657 | 6447SZ | 715629 |
| Partner (2008>) | + | x2 | ■■■ | 04/08 ▶ | 6447XF | 715554 | 6447XG | 715555 |
| Ranch (96>2002) | +/- | | ■■■ | 06/96 ▶ 12/00 | 6447Z5 | 698146 | | |
| Ranch (96>2002) | + | | ■■■ | 12/00 ▶ 11/02 | 6447KR | 698657 | | |
| Ranch (2002>) | + | | ■■■ | 11/02 ▶ | 6447KR | 698657 | 6447SZ | 715629 |
| PORSCHE  | | | | | | | | |
| 911 (996) | + | | ■■■ | 06/97 ▶ | 99657221901 | 698203 | 99657121903 | 698748 |
| 911 (997) | + | | ■■■ | 07/04 ▶ | 99657221901 | 698203 | 99757121900 | 698748 |
| 911 | + | | ■■■ | 12/11 ▶ | 99157237100 | 715754• | 99157362300 | 715753• |
| Boxster (986) | + | | ■■■ | 08/96 ▶ 10/04 | 99657221901 | 698203 | 99657121902 | 698748 |
| Boxster (987) | + | | ■■■ | 11/04 ▶ | 99657221901 | 698203 | 99757121900 | 698748 |
| Boxster Lyberta | + | | ■■■ | 12/11 ▶ | 99157237100 | 715754• | 99157362300 | 715753• |
| Cayenne | + | | ■■■ | 03/03 ▶ 05/10 | | | 95557221910 | 698768 |
| Cayman | + | | ■■■ | 11/05 ▶ 11/08 | 99657221901 | 698203 | 99757121900 | 698748 |
| Cayman | + | | ■■■ | 12/08 ▶ | | | 95857221900 | 715704 |
| Panamera | + | | ■■■ | 09/09 ▶ | | | 97057362300 | 715693 |
| RENAULT  | | | | | | | | |
| Avantime | + | x2 | ■■■ | 09/01 ▶ 03/03 | 6025370624 | 698290 | 6025372486 | 715568 |
| Captur | + | | ■■■ | 06/13 ▶ | 272773016R | 715746• | 272770567R | 715725 |
| Clio I | +/- | | ■■■ | 03/98 ▶ 03/01 | 7700424098 | 698255 | 7711228912 | 715538 |
| Clio II | +/- | | ■■■ | 04/01 ▶ 08/05 | 7700424098 | 698255 | 7711228912 | 715538 |
| Clio III | +/- | | ■■■ | 09/05 ▶ 03/09 | 7701062227 | 698753 | | |
| Clio III FL (2009>) | +/- | | ■■■ | 04/09 ▶ | 272775374R | 698753 | | |
| Clio IV | +/- | | ■■■ | 09/12 ▶ | 272773016R | 715746• | 272770567R | 715725 |
| Clio Campus Evolution | +/- | | ■■■ | 06/09 ▶ | 7700424098 | 698255 | 7711228912 | 715538 |
| Espace II | +/- | x2 | ■■■ | 01/91 ▶ 10/96 | 6025370624 | 698290 | 6025372486 | 715568 |
| Espace III | +/- | x2 | ■■■ | 10/96 ▶ 06/00 | 6025370624 | 698290 | 6025372486 | 715568 |
| Espace IV | +/- | | ■■■ | 09/02 ▶ | 7701056389 | 715562 | 7701056390 | 698737 |
| Fluence | + | | ■■■ | 02/10 ▶ | 272772100R | 715721 | 272774936R | 715722 |
| Koleos | + | | ■■■ | 09/08 ▶ | 27891JY15A | 715724 | 27891JY10A | 715667 |
| Laguna I | + |  | ■■■ | 01/94 ▶ 12/00 | 7700834816 | 698173 | | |
| Laguna II | +/- | | ■■■ | 01/01 ▶ 09/07 | 7701048748 | 698594 | 7701048749 | 698715 |
| Laguna III | +/- | x2 | ■■■ | 10/07 ▶ | | | 272770001R | 715607 |
| Latitude | +/- | x2 | ■■■ | 11/10 ▶ | | | 272774653R | 715734 |
| Mégane (95>99) | +/- | | ■■■ | 11/95 ▶ 04/98 | 7700845811 | 698149 | | |
| Mégane (95>99) | + | | ■■■ | 04/98 ▶ 02/99 | 7700424098 | 698255 | 7711228912 | 715538 |
| Mégane (95>99) | - | | ■■■ | 04/98 ▶ 02/99 | 7700424093 | 698276 | | |
| Mégane (98>2002) | + | | ■■■ | 05/98 ▶ 08/02 | 7700424098 | 698255 | 7711228912 | 715538 |

|  | AC |  |  |  | PA  OE Valeo | CA  OE Valeo | PCA  Valeo |
|--|-----|---|---|---|---|---|---|
| RENAULT  (.../...) | | | | | | | |
| Mégane (98>2002) | - | | ■ ■ ■ | 05/98 ▶ 08/02 | 7700424093 | 698276 | |
| Mégane II | + | | ■ ■ ■ | 09/02 ▶ 09/08 | 7701055109 | 698730 | 7701064235 715539 |
| Mégane III | +/- | | ■ ■ ■ | 10/08 ▶ | | | 272778970R 715647 701006 |
| Mégane Scénic (96>99) | +/- |  | ■ ■ ■ | 10/96 ▶ 01/98 | 7700845222 | 698177 | |
| Mégane Scénic (96>99) | + |  | ■ ■ ■ | 01/98 ▶ 09/99 | 7700428820 | 698279 | |
| Mégane Scénic (96>99) | + |  | ■ ■ ■ | 10/96 ▶ 09/99 | 7700845219 | 698176 | |
| Mégane Scénic (96>99) | - |  | ■ ■ ■ | 10/96 ▶ 09/99 | 7700846236 | 698175 | |
| Mégane Scénic (99>2003) | +/- |  | ■ ■ ■ | 09/99 ▶ 04/03 | 7701047513 | 698512 | |
| Mégane Scénic (99>2003) | +/- |  | ■ ■ ■ | 09/99 ▶ 04/03 | 7700846236 | 698175 | |
| Modus | +/- | | ■ ■ ■ | 09/04 ▶ | 7701062227 | 698753 | |
| Scénic II | +/- | | ■ ■ ■ | 05/03 ▶ 02/09 | 7701055110 | 698736 | 7701064237 715610 |
| Scénic II | + | | ■ ■ ■ | 03/09 ▶ | | | 272771128R 715672 701012 |
| Grand Scenic | +/- | | ■ ■ ■ | 06/09 ▶ | | | 272771128R 715672 701012 |
| Thalia | +/- | | ■ ■ ■ | 01/01 ▶ | 7700424098 | 698255 | 7711228912 715538 701018 |
| Twingo I | + | | ■ ■ ■ | 08/94 ▶ 08/98 | 7701409324 | 698878 | |
| Twingo II | + | | ■ ■ ■ | 09/98 ▶ 06/07 | 7701409324 | 698878 | |
| Twingo III | +/- | | ■ ■ ■ | 07/07 ▶ | 7701062227 | 698753 | |
| Vel Satis | +/- | | ■ ■ ■ | 01/02 ▶ | | | 7701048749 698715 701015 |
| Vel Satis | A+ | | ■ ■ ■ | 01/02 ▶ | 7701048748 | 698594 | |
| Wind | M+ | | ■ ■ ■ | 07/10 ▶ | 272775374R | 698753 | |
| RENAULT  | | | | | | | |
| Kangoo (97>2003) | +/- | | ■ ■ ■ | 09/97 ▶ | 7701042499 | 715633 | |
| Kangoo (97>2003) | - | | ■ ■ ■ | 11/99 ▶ 02/03 | 7700424098 | 698255 | 7711228912 715538 701018 |
| Kangoo (2003>2007) | + | | ■ ■ ■ | 03/03 ▶ 01/08 | 7700424098 | 698255 | 7711228912 715538 701018 |
| Kangoo (2008>) | + | x2 | ■ ■ ■ | 02/08 ▶ | 7701209837 | 715649 | |
| Kangoo Be Bop | + | x2 | ■ ■ ■ | 02/08 ▶ | 7701209837 | 715649 | |
| Master | + | x2 | ■ ■ ■ | 04/10 ▶ | 7701209837 | 715649 | |
| Trafic | + | | ■ ■ ■ | 04/01 ▶ | 7701050319 | 715513 | |
| ROLLS ROYCE  | | | | | | | |
| Phantom | +/- | x2 | ■ ■ ■ | 01/03 ▶ | | | 64116921019 698857 |
| Ghost | A+ | x2 | ■ ■ ■ | 11/09 ▶ | | | 64119163329 715690 |
| ROVER  | | | | | | | |
| 25 | +/- | | ■ ■ ■ | 12/99 ▶ | JKR100020 | 698196 | |
| 45 | + | | ■ ■ ■ | 01/00 ▶ 04/05 | JKX100010 | 698819 | |
| 45 | - | | ■ ■ ■ | 01/00 ▶ 04/05 | JKR100020 | 698196 | |
| 75 | + | | ■ ■ ■ | 02/99 ▶ | JKR100183 | 698879 | JKR000040 698880 |
| 200 | +/- | | ■ ■ ■ | 09/90 ▶ 01/00 | JKX100010 | 698819 | |
| 200 | - | | ■ ■ ■ | 09/90 ▶ 01/00 | JKR100020 | 698196 | |
| 400 | + | | ■ ■ ■ | 01/95 ▶ 03/00 | JKX100010 | 698819 | |
| 400 | - | | ■ ■ ■ | 01/95 ▶ 03/00 | JKR100080 | 698869 | |
| Streetwise | + | | ■ ■ ■ | 08/03 ▶ | JKR100020 | 698196 | |

|  | AC |  |  |  | PA    | CA    | PCA   | |
|---|-----|---|---|---|--|--|---|---------------|
| SAAB  | | | | | | | | |
| 9-2x | + | | | 2004 ▶ 2006 | | G3210FE000 | 715680 | |
| 9-3 (98>2002) | + | | ■ ■ ■ ■ | 04/98 ▶ 09/02 | 5047113 | 715514 | | |
| 9-3 (2002>) | + | | ■ ■ ■ ■ | 09/02 ▶ | 93172229 | 698711 | 9179904 | 698710 701010 |
| 9-3 Cabriolet | +/- | | ■ ■ ■ ■ | 08/03 ▶ | 93172229 | 698711 | 9179904 | 698710 701010 |
| 9-5 (97>2001) | +/- | | ■ ■ ■ ■ | 09/97 ▶ 08/01 | | | 12758727 | 698723 |
| 9-5 (2001>) | + | | ■ ■ ■ ■ | 09/01 ▶ | | | 12758727 | 698723 |
| 9-5 (2011>) | + | | ■ ■ ■ ■ | 03/11 ▶ | 13271190 | 715658 | 13271191 | 715659 |
| 900 (93>98) | +/- | | ■ ■ ■ ■ | 07/93 ▶ 02/98 | 5047113 | 715514 | | |
| 9000 | + | | ■ ■ ■ ■ | 06/84 ▶ 07/91 | 9625674 | 698199 | | |
| SATURN  | | | | | | | | |
| Vue | + | | ■ ■ ■ ■ | 06/06 ▶ | 615974 | 715654 | | |
| SCION  | | | | | | | | |
| xA | +/- | | ■ ■ ■ ■ | 05/03 ▶ 10/07 | 8856852010 | 698681 | 8974000820 | 715650 |
| xB | + | | ■ ■ ■ ■ | 05/03 ▶ 10/07 | 8856852010 | 698681 | 8974000820 | 715650 |
| SEAT  | | | | | | | | |
| Alhambra I | + | | ■ ■ ■ ■ | 03/96 ▶ 05/00 | 7M0819644 | 698247 | 7M3819644 | 698696 |
| Alhambra II | +/- | | ■ ■ ■ ■ | 06/00 ▶ 03/10 | 7M0819644 | 698247 | 7M3819644 | 698696 |
| Alhambra III | +/- |  | ■ ■ ■ ■ | 04/10 ▶ | 1K0819644 | 698800 | 1K1819653B | 698801 701001 |
| Alhambra III | +/- |  | ■ ■ ■ ■ | 04/10 ▶ | | | 1K2819653B | 715665 |
| Altea | +/- |  | ■ ■ ■ ■ | 03/04 ▶ | 1K0819644A | 698800 | 1K1819653A | 698801 701001 |
| Arosa | +/- | | ■ ■ ■ ■ | 02/97 ▶ 08/00 | 1H0819644B | 698159 | 1H0091800 | 698686 |
| Arosa | +/- | | ■ ■ ■ ■ | 09/00 ▶ | 1H0819644B | 698159 | 1J0819644 | 698716 701016 |
| Arosa | + | w/o Plastic Frame | ■ ■ ■ ■ | 02/97 ▶ | 1H0819644B | 698885 | | |
| Cordoba (93>96) | +/- | | ■ ■ ■ ■ | 09/93 ▶ 06/96 | 1H0819644B | 698159 | 1H0091800 | 698686 |
| Cordoba (93>96) | +/- | w/o Plastic Frame | ■ ■ ■ ■ | 09/93 ▶ 06/96 | 1H0819644B | 698885 | | |
| Cordoba (96>99) | +/- | | ■ ■ ■ ■ | 07/96 ▶ 05/99 | 1H0819644B | 698159 | 1H0091800 | 698686 |
| Cordoba (96>99) | +/- | w/o Plastic Frame | ■ ■ ■ ■ | 07/96 ▶ 05/99 | 1H0819644B | 698885 | | |
| Cordoba (99>2002) | +/- | | ■ ■ ■ ■ | 05/99 ▶ 08/02 | 1H0819644B | 698159 | 1H0091800 | 698686 |
| Cordoba (99>2002) | +/- | w/o Plastic Frame | ■ ■ ■ ■ | 05/99 ▶ 08/02 | 1H0819644B | 698885 | | |
| Cordoba (2002>) | +/- | | ■ ■ ■ ■ | 09/02 ▶ | 600820367 | 698685 | 600819653 | 698739 701009 |
| Exeo | +/- | | ■ ■ ■ ■ | 03/09 ▶ | 8E0819439 | 698606 | 4B0819439C | 698683 701023 |
| Ibiza (93>99) | +/- | | ■ ■ ■ ■ | 02/93 ▶ 06/99 | 1H0819644B | 698159 | 1H0091800 | 698686 |
| Ibiza (93>99) | +/- | w/o Plastic Frame | ■ ■ ■ ■ | 02/93 ▶ 06/99 | 1H0819644B | 698885 | | |
| Ibiza (99>2001) | +/- | | ■ ■ ■ ■ | 07/99 ▶ 08/01 | 1H0819644B | 698159 | 1H0091800 | 698686 |
| Ibiza (99>2001) | +/- | w/o Plastic Frame | ■ ■ ■ ■ | 07/99 ▶ 08/01 | 1H0819644B | 698885 | | |
| Ibiza (2001>2011) | +/- | | ■ ■ ■ ■ | 09/01 ▶ 01/12 | 600820367 | 698685 | 600819653 | 698739 701009 |
| Ibiza | +/- | | ■ ■ ■ ■ | 10/10 ▶ | 6R0820367 | 715737 | 6R0819653 | 715727 |
| Leon (99>2005) | +/- | | ■ ■ ■ ■ | 08/99 ▶ 09/05 | 1H0819644B | 698159 | 1J0819644 | 698716 701016 |
| Leon (99>2005) | +/- | w/o Plastic Frame | ■ ■ ■ ■ | 08/99 ▶ 09/05 | 1H0819644B | 698885 | | |
| Leon (2005>) | +/- |  | ■ ■ ■ ■ | 09/05 ▶ 08/12 | 1K0819644A | 698800 | | |
| Leon (2005>) | - |  | ■ ■ ■ ■ | 09/05 ▶ 08/12 | | | 1K1819653 | 698801 701001 |























|  | AC |  |  |  | PA  OE Valeo | CA  OE Valeo | PCA  Valeo | |
|---|-----|---|---|---|---|---|---|--------|
| SEAT  (.../...) | | | | | | | | |
| Leon (2005>) | + |  | ■ ■ ■ | 11/05 ▶ 05/07 | | 1K2819653A | 715665 | |
| Leon (2012>) | A+ | ultrafine | ■ ■ ■ | 09/12 ▶ | | 5Q0818653 | 715720 | 701020 |
| Mii | +/- | | ■ ■ ■ | 10/11 ▶ | 1S0820367 | 715744 | | |
| Toledo (91>1998) | +/- | | ■ ■ ■ | 05/91 ▶ 10/98 | 191819638 | 715653 | | |
| Toledo (98>2004) | - | | ■ ■ ■ | 10/98 ▶ 07/04 | 1H0819644B | 698159 | 1H0091800 | 698686 |
| Toledo (98>2004) | + | | ■ ■ ■ | 10/98 ▶ 07/04 | 1H0819644B | 698159 | 1H0091800 | 698686 |
| Toledo (98>2004) | - | w/o Plastic Frame | ■ ■ ■ | 10/98 ▶ 07/04 | 1H0819644B | 698885 | | |
| Toledo (2004>) | +/- |  | ■ ■ ■ | 09/04 ▶ | 1K0819644A | 698800 | | |
| Toledo | +/- |  | ■ ■ ■ | 01/03 ▶ | | | 1K2819653A | 715665 |
| Toledo IV | +/- | | ■ ■ ■ | 10/12 ▶ | 6R0820367 | 715737 | 6R0819653 | 715727 |
| SEAT  | | | | | | | | |
| Inca | +/- | | ■ ■ ■ | 11/95 ▶ 06/03 | 1H0819644B | 698159 | 1H0091800 | 698686 |
| Inca | +/- | w/o Plastic Frame | ■ ■ ■ | 11/95 ▶ 06/03 | 1H0819644B | 698885 | | |
| SKODA  | | | | | | | | |
| Citigo | +/- | | ■ ■ ■ | 10/11 ▶ | 1S0820367 | 715744 | | |
| Fabia (99>2010) | +/- | | ■ ■ ■ | 08/99 ▶ 06/10 | 600820367 | 698685 | 6Q0819653 | 698739 |
| Fabia | +/- | | ■ ■ ■ | 07/10 ▶ | 6R0820367 | 715737 | 6R0819653 | 715727 |
| Felicia (94>2001) | +/- | | ■ ■ ■ | 10/94 ▶ 08/01 | | | 6Q0819653 | 698739 |
| Felicia (2006>2010) | +/- | | ■ ■ ■ | 03/06 ▶ 07/10 | 600820367B | 698685 | 6Q0819653 | 698739 |
| Octavia | +/- | w/o Plastic Frame | ■ ■ ■ | 10/96 ▶ 05/04 | 1H0819644B | 698885 | | |
| Octavia | +/- | With Plastic Frame | ■ ■ ■ | 08/00 ▶ 12/10 | 1H0819644B | 698159 | 1J0819644A | 698716 |
| Octavia (96>2004) | +/- | | ■ ■ ■ | 10/96 ▶ 05/04 | 1H0819644B | 698159 | 1H0091800 | 698686 |
| Octavia (2004>) | +/- |  | ■ ■ ■ | 05/04 ▶ 10/12 | 1K0819644A | 698800 | 1K1819653A | 698801 |
| Octavia (2004>) | +/- |  | ■ ■ ■ | 06/04 ▶ 10/12 | | | 1K2819653A | 715665 |
| Octavia (2012>) | + | ultrafine | ■ ■ ■ | 11/12 ▶ | | | 5Q0818653 | 715720 |
| Praktik | +/- | | ■ ■ ■ | 08/10 ▶ | 6R0820367 | 715737 | 6R0819653 | 715727 |
| Rapid | +/- | | ■ ■ ■ | 03/06 ▶ 07/10 | 600820367B | 698685 | 6Q0819653 | 698739 |
| Rapid | +/- | | ■ ■ ■ | 08/10 ▶ | 6R0820367 | 715737 | 6R0819653 | 715727 |
| Roomster | +/- | | ■ ■ ■ | 03/06 ▶ 07/10 | 600820367 | 698685 | 6Q0819653 | 698739 |
| Roomster | +/- | | ■ ■ ■ | 08/10 ▶ | 6R0820367 | 715737 | 6R0819653 | 715727 |
| Superb | +/- | | ■ ■ ■ | 02/02 ▶ 03/08 | 1H0819644B | 698159 | 1H0091800 | 698686 |
| Superb | + | w/o Plastic Frame | ■ ■ ■ | 02/02 ▶ 03/08 | 1H0819644B | 698885 | | |
| Superb (2008>) | + |  | ■ ■ ■ | 04/08 ▶ | 1K0819644B | 698800 | 1K1819653B | 698801 |
| Superb (2008>) | +/- |  | ■ ■ ■ | 03/08 ▶ | | | 1K2819653B | 715665 |
| Yeti | +/- | | ■ ■ ■ | 08/09 ▶ | 1K0819644B | 698800 | 1K1819653B | 698801 |
| SMART  | | | | | | | | |
| Crossblade | +/- | | ■ ■ ■ | 06/02 ▶ | | | 0001110V004 | 698774 |
| Forfour | +/- | | ■ ■ ■ | 04/04 ▶ | | | 0013871V001 | 698802 |
| Fortwo | +/- | | ■ ■ ■ | 03/07 ▶ | 4518350247 | 715736 | 4518300018 | 715608 |
| Fortwo, City Coupe | +/- | | ■ ■ ■ | 10/98 ▶ | | | 0001110V004 | 698774 |
| Roadster, coupe | +/- | | ■ ■ ■ | 05/03 ▶ | | | 0013871V001 | 698802 |

|  | AC |  |  |  | PA  OE Valeo | CA  OE Valeo | PCA  Valeo | | |
|--|-----|---|---|---|---|---|---|--------|--------|
| SSANGYONG  | | | | | | | | | |
| Actyon | +/- | x2 | ■■■ | 03/05 ▶ | 68111091A0 | 715624 | | | |
| Actyon Sports | + | x2 | ■■■ | 04/07 ▶ | 68111091A0 | 715624 | | | |
| Korando | + | x2 | | 07/96 ▶ 03/99 | 6923005400 | 715566 | | | |
| Korando | + | x2 | | 07/96 ▶ 03/99 | 6923005410 | 715567 | | | |
| Kyron | - | x2 | ■■■ | 05/05 ▶ | 68111091A0 | 715624 | | | |
| Musso | + | x2 | | 1998 ▶ 2005 | 6923005400 | 715566 | | | |
| Musso | M+ | x2 | | 1998 ▶ 2005 | 6923005410 | 715567 | | | |
| Musso Sport | A+ | x2 | | 10/95 ▶ | 6923005400 | 715566 | | | |
| Musso Sport | + | x2 | | 10/95 ▶ | 6923005410 | 715567 | | | |
| Rexton | - | x2 | | 04/02 ▶ | 6812008030 | 715699 | | | |
| Rodius | + | x2 | | 05/05 ▶ | 6811021000 | 715700 | | | |
| SUBARU  | | | | | | | | | |
| B9 Tribeca | + | | ■■■ | 09/06 ▶ | 72880XA00A | 698796 | | | |
| Forester I | + | | ■■■ | 08/97 ▶ 09/02 | GE210FC000 | 715626 | | | |
| Forester II | + | | ■■■ | 09/02 ▶ | 72880SA000 | 715651 | | | |
| Forester III | + | | ■■■ | 07/07 ▶ | 72880FG000 | 715625 | | | |
| Impreza I | + | | ■■■ | 12/96 ▶ 12/00 | GE210FC000 | 715626 | | | |
| Impreza II | + | | | 12/00 ▶ 06/07 | 72880FE000 | 715551 | G3210FE000 | 715680 | |
| Impreza III | +/- | | ■■■ | 07/07 ▶ | 72880FG000 | 715625 | | | |
| Justy III | + | | ■■■ | 10/03 ▶ | 9586078F10 | 698773 | | | |
| Justy IV | +/- | | ■■■ | 09/07 ▶ | 99906850M2-038 | 715637 | | | |
| Legacy (98>2003) | +/- | x2 | ■■■ | 10/98 ▶ 04/03 | G3210AE000 | 715563 | | | |
| Legacy (2003>) | + | | ■■■ | 05/03 ▶ | 72880AG000 | 698796 | 72880AG000 | 715619 | |
| Legacy | + | | ■■■ | 09/09 ▶ | 72880AJ000 | 715620 | 8713950060 | 715730 | 701021 |
| Outback (2000>2003) | + | x2 | ■■■ | 10/00 ▶ 04/03 | G3210AE000 | 715563 | | | |
| Outback (2003>) | + | | ■■■ | 05/03 ▶ | 72880AG000 | 698796 | 72880AG000 | 715619 | |
| Outback | + | | ■■■ | 09/09 ▶ | 72880AJ000 | 715620 | 8713950060 | 715730 | 701021 |
| Tribeca | + | | ■■■ | 01/05 ▶ | 72880XA000A | 698796 | 72880XA000A | 715619 | |
| Trezia | + | | ■■■ | 03/11 ▶ | 72880AJ000 | 715620 | 8713950060 | 715730 | 701021 |
| SUZUKI  | | | | | | | | | |
| Alto | + | | ■■■ | 03/09 ▶ | 95861M68K10 | 715694 | | | |
| Grand Vitara I | + | x2 | ■■■ | 05/98 ▶ 03/03 | 9586165D000 | 698894 | | | |
| Grand Vitara II | + | | ■■■ | 04/03 ▶ 10/05 | 9586154J00 | 715564 | | | |
| Grand Vitara III | + | | ■■■ | 10/05 ▶ | 9586164J00 | 715609 | | | |
| Ignis | + | | ■■■ | 09/03 ▶ | 9586078F10 | 698773 | | | |
| Jimny | +/- | | ■■■ | 09/98 ▶ | 9586081A10 | 715668 | | | |
| Kizashi Sport | + | | ■■■ | 09/10 ▶ | 9586157L00 | 715743 | | | |
| Liana | +/- | | ■■■ | 06/01 ▶ | 9586154G00 | 715698 | | | |
| Splash | +/- | | ■■■ | 05/08 ▶ | 9586051K00 | 715644 | | | |
| Swift | +/- | | ■■■ | 04/05 ▶ | 9586062J000 | 698886 | | | |
| SX4 | +/- | SX4 JAP | ■■■ | 05/06 ▶ | 9586080J00 | 715652 | | | |















|  | AC |  |  |  | PA  OE Valeo | CA  OE Valeo | PCA  Valeo | |
|---|-----|--|---|---|---|---|---|-----------------------------|
| SUZUKI  (.../...) | | | | | | | | |
| SX4 | +/- | SX4 HUN | ■■■ | 05/06 ▶ | 9586062J000 | 698886 | | |
| Wagon R+ | +/- | | ■■■ | 03/00 ▶ | 9586078F10 | 698773 | | |
| TOYOTA  | | | | | | | | |
| 4 Runner | +/- | | ■■■ | 01/03 ▶ | 871394701083 | 698796 | 87139VZ203 | 715619 |
| Alphard II | + | | ■■■ | 04/08 ▶ | 8713952020 | 715620 | 8713950060 | 715730 701021 |
| Auris | +/- | | ■■■ | 03/06 ▶ | 8713902020 | 715620 | 8713950060 | 715730 701021 |
| Avalon | + | | ■■■ | 04/00 ▶ 11/04 | 871394701083 | 698796 | 8713933010 | 715619 |
| Avalon | + | | ■■■ | 02/05 ▶ | 87139VZ208 | 715620 | 8713950060 | 715730 701021 |
| Avensis (T22) | + |  x2 | ■■■ | 10/97 ▶ 01/03 | 8888020060 | 715572 | | |
| Avensis (T25) | + | | ■■■ | 01/03 ▶ | 8856802030 | 698795 | | |
| Avensis (T27) | + | | ■■■ | 11/08 ▶ | 87139VZ208 | 715620 | 8713950060 | 715730 701021 |
| Avensis Verso (2001>) | + | | ■■■ | 05/01 ▶ | 871394701083 | 698796 | 0897400850 | 715701 |
| Aygo | + | | ■■■ | 02/05 ▶ | 885080H010 | 715515 | | |
| Camry | + | | ■■■ | 08/01 ▶ 01/06 | 871394701083 | 698796 | 87139VZ203 | 715619 |
| Camry | + | | ■■■ | 02/06 ▶ | 8713952020 | 715620 | 8713950060 | 715730 701021 |
| Carina E (T19) | +/- |  x2 | ■■■ | 01/96 ▶ 12/97 | 8888020060 | 715572 | | |
| Celica (ZT230) (99>) | + | | ■■■ | 08/99 ▶ | 871394701083 | 698796 | 8713933010 | 715619 |
| Corolla (110) (97-99) | + | | ■■■ | 04/97 ▶ 11/99 | 8850812010 | 715565 | | |
| Corolla (110) (99>2001) | + | | ■■■ | 10/99 ▶ 10/01 | 8850812010 | 715565 | | |
| Corolla (120) (2001>) | + | | ■■■ | 10/01 ▶ | 8856802030 | 698795 | | |
| Corolla X | +/- | | ■■■ | 04/07 ▶ | 8713952020 | 715620 | 8713950060 | 715730 701021 |
| Corolla Verso (2001>) | +/- | | ■■■ | 09/01 ▶ | 8856802030 | 698795 | 0897400850 | 715701 |
| Corolla Verso (E12J) 2.0 D4D | + | | ■■■ | 01/02 ▶ 05/04 | 87139VZ206 | 715689 | 0897400850 | 715701 |
| Echo | + | | ■■■ | 06/99 ▶ 07/05 | 8856852010 | 698681 | 8974000820 | 715650 |
| FJ Cruiser | + | | ■■■ | 02/06 ▶ | 871394701083 | 698796 | 8713933010 | 715619 |
| Harrier | + | | ■■■ | 07/98 ▶ | 8713948020 | 715542 | 8850530100 | 715729 |
| Highlander I | + | | ■■■ | 05/01 ▶ 11/07 | 8713930010 | 715542 | 8850530100 | 715729 |
| Highlander II | + | | ■■■ | 12/07 ▶ | 8713952020 | 715620 | 8713950060 | 715730 701021 |
| Hilux | +/- | | ■■■ | 08/08 ▶ | 87139VZ208 | 715620 | 8713950060 | 715730 701021 |
| Land Cruiser | + | | ■■■ | 01/98 ▶ 09/02 | 8713952020 | 715620 | 8713950060 | 715730 701021 |
| Land Cruiser | +/- | | ■■■ | 09/02 ▶ | 871394701083 | 698796 | 8713933010 | 715619 |
| Land Cruiser Prado | + | | ■■■ | 08/09 ▶ | 87139VZ208 | 715620 | 8713950060 | 715730 701021 |
| Matrix | + | | ■■■ | 04/03 ▶ | 871394701083 | 698796 | 8713933010 | 715619 |
| Picnic (96>2001) | + |  x2 | ■■■ | 09/96 ▶ 05/01 | 8888020020 | 715572 | | |
| Picnic (2001>) | + | | ■■■ | 05/01 ▶ 07/05 | 8713947010 | 698796 | | |
| Previa (R30) | + | | ■■■ | 02/00 ▶ | 871394701083 | 698796 | 8713933010 | 715619 |
| Prius | + | | ■■■ | 05/00 ▶ | 871394701083 | 698796 | 8713933010 | 715619 |
| RAV4 (2000>2006) | + | | ■■■ | 05/00 ▶ 02/06 | 8856852010 | 698681 | 8974000820 | 715650 |
| RAV4 II (2006>) | + | | ■■■ | 03/06 ▶ | 8713952020 | 715620 | 8713950060 | 715730 701021 |
| Sienna | + | | ■■■ | 06/04 ▶ 07/06 | 871394701083 | 698796 | 87139VZ203 | 715619 |
| Tundra | + | | ■■■ | 01/07 ▶ | 8713952020 | 715620 | 8713950060 | 715730 701021 |

|  | AC |  |  |  | PA   | CA   | PCA  | | |
|---|-----|--|---|---|---|---|--|----------------|---------------|
| TOYOTA  (.../...) | | | | | | | | | |
| Urban Cruiser | +/- | | ■■■■ | 01/09 ▶ | 871397Z08 | 715620 | 8713950060 | 715730 | 701021 |
| Verso | + | | ■■■■ | 04/09 ▶ | 8713952020 | 715620 | 8713950060 | 715730 | 701021 |
| Verso-S | +/- | | ■■■■ | 11/10 ▶ | 8713902020 | 715620 | 8713950060 | 715730 | 701021 |
| Yaris | +/- | Yaris FR | ■■■■ | 01/01 ▶ 10/05 | 871394701083 | 698796 | 8713933010 | 715619 | |
| Yaris | + | Yaris FR | ■■■■ | 01/01 ▶ 10/05 | 871394701083 | 698796 | 8713933010 | 715619 | |
| Yaris (NCP/SCP) | - | Yaris JAP | ■■■■ | 01/99 ▶ 10/05 | 8856852010 | 698681 | 8974000820 | 715650 | |
| Yaris (NCP/SCP) | + | Yaris JAP | ■■■■ | 01/99 ▶ 10/05 | 8856852010 | 698681 | 8974000820 | 715650 | |
| Yaris Verso | - | | ■■■■ | 08/99 ▶ 11/01 | 8856852010 | 698681 | 8974000820 | 715650 | |
| Yaris Verso | +/- | | ■■■■ | 12/01 ▶ | 8713947010 | 698796 | 8713933010 | 715619 | |
| Yaris II | +/- | | ■■■■ | 01/06 ▶ 08/11 | 8713952020 | 715620 | 8713950060 | 715730 | 701021 |
| Yaris III | + | | ■■■■ | 09/11 ▶ | 8713952020 | 715620 | 8713950060 | 715730 | 701021 |
| VAUXHALL  | | | | | | | | | |
| Agila | +/- |  | ■■■■ | 06/00 ▶ 12/07 | 9196805 | 698773 | | | |
| Agila | +/- |  | ■■■■ | 02/08 ▶ | 93194847 | 715644 | | | |
| Antara | +/- |  | ■■■■ | 06/06 ▶ | 96440878 | 715654 | | | |
| Astra III (91>98) | +/- |  | ■■■■ | 09/91 ▶ 03/98 | 9200067 | 698165 | 9121625 | 715632 | |
| Astra IV (98>2004) | + |  Delphi | ■■■■ | 04/98 ▶ 03/04 | 90520689 | 698662 | 91132359 | 698875 | |
| Astra IV (98>2004) | +/- |  Behr | ■■■■ | 04/98 ▶ 03/04 | 90559549 | 698663 | 91132364 | 698708 | 701008 |
| Astra V (2004>) | +/- |  | ■■■■ | 03/04 ▶ | 13175553 | 698662 | 13175554 | 698875 | |
| Belmont | +/- | | ■■■■ | 01/86 ▶ 09/91 | 93182435 | 698165 | | | |
| Calibra | +/- |  | ■■■■ | 06/90 ▶ 07/97 | 9200067 | 698165 | 9121625 | 715632 | |
| Corsa I (93>2000) | +/- |  | ■■■■ | 04/93 ▶ 08/00 | 90509367 | 698166 | | | |
| Corsa I (93>2000) | - |  | ■■■■ | 04/93 ▶ 08/00 | 90512706 | 715645 | | | |
| Corsa II (2000>2003) | + |  | ■■■■ | 09/00 ▶ 08/03 | 93172299 | 698711 | 93172129 | 698710 | 701010 |
| Corsa II (2003>2006) | +/- |  | ■■■■ | 09/03 ▶ 06/06 | 93172299 | 698711 | 93172129 | 698710 | 701010 |
| Corsa III (2006>) | +/- |  | ■■■■ | 07/06 ▶ | 55702456 | 715552 | 55702468 | 715553 | 701003 |
| Insignia | +/- |  | ■■■■ | 01/09 ▶ | 52425938 | 715658 | 52420930 | 715659 | |
| Meriva | + |  | ■■■■ | 05/03 ▶ | 93174800 | 698876 | 93174801 | 698877 | |
| Meriva | +/- |  | ■■■■ | 05/10 ▶ | 52425938 | 715658 | 13271191 | 715659 | |
| Meriva B | +/- | | ■■■■ | 05/10 ▶ | | | 13356914 | 715752* | |
| Mokka | |  | ■■■■ | 12/12 ▶ | | | 1808246 | 715659 | |
| Monterey | +/- | x2 | ■■■■ | 04/98 ▶ 08/99 | 97170804 | 715669 | | | |
| Omega | + |  | ■■■■ | 04/94 ▶ | 90510338 | 698167 | 9192320 | 698746 | |
| Signum | +/- |  | ■■■■ | 06/03 ▶ | 93172299 | 698711 | 93172129 | 698710 | 701010 |
| Sintra | +/- |  x2 | ■■■■ | 03/96 ▶ 12/99 | 52470574 | 698712 | | | |
| Tigra | + |  | ■■■■ | 11/94 ▶ 01/01 | 90509367 | 698166 | | | |
| Tigra | - |  | ■■■■ | 11/94 ▶ 01/01 | 90512706 | 715645 | | | |
| Tigra Twin Top | + |  | ■■■■ | 06/04 ▶ | 93172299 | 698711 | 93172129 | 698710 | 701010 |
| Vectra (95>2002) | +/- |  | ■■■■ | 10/95 ▶ 03/02 | 90512779 | 698202 | 90541317 | 715675 | |
| Vectra (2002>) | +/- |  | ■■■■ | 04/02 ▶ | 93172299 | 698711 | 93172129 | 698710 | 701010 |

|  | AC |  |  |  | PA   | CA   | PCA  | | |
|---|-----|---|---|---|---|---|--|---------------|---------------|
| VAUXHALL  (.../...) | | | | | | | | | |
| Zafira | +/- |  | ■ ■ ■ | 05/99 ▶ 09/11 | 93182436 | 698663 | 91132364 | 698708 | 701008 |
| Zafira (2011>) | +/- | | ■ ■ ■ | 10/11 ▶ | | | 13271191 | 715659 | |
| Combo (2012>) | + |  | ■ ■ ■ | 02/12 ▶ | 55702456 | 715552 | 55702468 | 715553 | 701003 |
| VAUXHALL  | | | | | | | | | |
| Combo (93>2001) | +/- |  | ■ ■ ■ | 10/93 ▶ 09/01 | 90509367 | 698166 | | | |
| Combo (93>2001) | - |  | ■ ■ ■ | 10/93 ▶ 09/01 | 9200067 | 698165 | 9121625 | 715632 | |
| Combo (2001>) | + |  | ■ ■ ■ | 10/01 ▶ | 93172299 | 698711 | | | |
| Combo (2001>) | - |  | ■ ■ ■ | 10/01 ▶ | | | 93172129 | 698710 | 701010 |
| Movano | +/- |  | ■ ■ ■ | 07/98 ▶ | 4408840 | 715513 | | | |
| Vivaro | +/- |  | ■ ■ ■ | 08/01 ▶ | 91160128 | 715513 | | | |
| VOLKSWAGEN  | | | | | | | | | |
| Amarok | +/- | | ■ ■ ■ | 11/09 ▶ | 7H0819631 | 715581 | | | |
| Bora | +/- | | ■ ■ ■ | 09/98 ▶ 07/05 | 1H0819644B | 698159 | 1J0819644A | 698716 | 701016 |
| Bora | +/- | w/o Plastic Frame | ■ ■ ■ | 09/98 ▶ 07/05 | 1H0819644B | 698885 | | | |
| Eos | +/- |  | ■ ■ ■ | 03/06 ▶ | 1K0819644A | 698800 | 1K1819653A | 698801 | 701001 |
| Eos | +/- |  | ■ ■ ■ | 05/06 ▶ | | | 1K2819653B | 715665 | |
| Fox | +/- | | ■ ■ ■ | 11/04 ▶ | 600820367 | 698685 | 6Q0819653 | 698739 | 701009 |
| Golf I | +/- | | ■ ■ ■ | 08/83 ▶ 04/93 | 191819638 | 715653 | | | |
| Golf I Cabriolet | - | | ■ ■ ■ | 08/83 ▶ 04/93 | 191819638 | 715653 | | | |
| Golf II Cabriolet | - | | ■ ■ ■ | 11/91 ▶ 02/98 | 1H0819644B | 698159 | 1H0091800 | 698686 | |
| Golf III | + | | ■ ■ ■ | 09/91 ▶ 07/93 | 1H0819638 | 698160 | | | |
| Golf III | +/- | | ■ ■ ■ | 07/93 ▶ 10/97 | 1H0819644B | 698159 | 1H0091800 | 698686 | |
| Golf III | +/- | w/o Plastic Frame | ■ ■ ■ | 11/91 ▶ 10/97 | 1H0819644B | 698885 | | | |
| Golf III Cabriolet | +/- | | ■ ■ ■ | 03/98 ▶ 04/02 | 1H0819644B | 698159 | 1H0091800 | 698686 | |
| Golf IV | +/- | | ■ ■ ■ | 10/97 ▶ 10/03 | 1H0819644B | 698159 | 1J0819644A | 698716 | 701016 |
| Golf IV | +/- | w/o Plastic Frame | ■ ■ ■ | 10/97 ▶ 10/03 | 1H0819644B | 698885 | | | |
| Golf V | +/- |  | ■ ■ ■ | 10/03 ▶ 09/08 | 1K0819644A | 698800 | | | |
| Golf V | - |  | ■ ■ ■ | 10/03 ▶ 09/08 | 1K0819644A | 698800 | 1K1819653A | 698801 | 701001 |
| Golf V | + |  | ■ ■ ■ | 10/03 ▶ 09/08 | | | 1K2819653A | 715665 | |
| Golf VI | +/- |  | ■ ■ ■ | 10/08 ▶ | 1K0819644A | 698800 | 1K1819653A | 698801 | 701001 |
| Golf VI | +/- |  | ■ ■ ■ | 10/08 ▶ | | | 1K2819653B | 715665 | |
| Golf VI Cabriolet | +/- |  | ■ ■ ■ | 05/12 ▶ | | | 1K2819653B | 715665 | |
| Golf VI Cabriolet | +/- |  | ■ ■ ■ | 05/12 ▶ | 1K0819644B | 698800 | 1K1819653B | 698801 | 701001 |
| Golf VII | +/- | ultrafine | ■ ■ ■ | 09/12 ▶ | | | 5Q0818653 | 715720 | 701020 |
| Golf Plus | +/- |  | ■ ■ ■ | 01/05 ▶ | 1K0819644A | 698800 | 1K1819653A | 698801 | 701001 |
| Golf Plus | +/- |  | ■ ■ ■ | 01/05 ▶ | | | 1K2819653B | 715665 | |
| Jetta (83>92) | +/- | | ■ ■ ■ | 08/83 ▶ 07/92 | 191819638 | 715653 | | | |
| Jetta (2005>) | - |  | ■ ■ ■ | 08/05 ▶ | 1K0819644A | 698800 | 1K1819653A | 698801 | 701001 |
| Jetta (2005>) | +/- |  | ■ ■ ■ | 08/05 ▶ | | | 1K2819653B | 715665 | |
| Lupo | +/- | | ■ ■ ■ | 10/98 ▶ 07/05 | 1H0819644B | 698159 | 1J0819644A | 698716 | 701016 |

|  | AC |  |  |  | PA   | CA   | PCA  | |
|---|-----|---|---|---|---|---|--|---------------|
| VOLKSWAGEN  (.../...) | | | | | | | | |
| Lupo | +/- | w/o Plastic Frame | ■■■■ | 10/98 ▶ 07/05 | 1H0819644B | 698885 | | |
| New Beetle (98>2001) | +/- | | ■■■■ | 11/98 ▶ 05/01 | 1H0819644B | 698159 | 1J0819644A | 698716 |
| New Beetle (98>2001) | +/- | w/o Plastic Frame | ■■■■ | 01/98 ▶ 05/01 | 1H0819644B | 698885 | | |
| New Beetle (2001>2005) | +/- | w/o Plastic Frame | ■■■■ | 06/01 ▶ 06/05 | 1H0819644B | 698885 | | |
| New Beetle (2001>2005) | +/- | | ■■■■ | 06/01 ▶ 06/05 | 1H0819644B | 698159 | 1J0819644A | 698716 |
| New Beetle (2005>) | +/- | w/o Plastic Frame | ■■■■ | 07/05 ▶ | 1H0819644B | 698885 | | |
| New Beetle (2005>) | +/- | | ■■■■ | 07/05 ▶ | | | 1J0819644A | 698716 |
| New Beetle (2011>) | +/- |  | ■■■■ | 07/11 ▶ | 1K0819644B | 698800 | 1K1819653B | 698801 |
| New Beetle (2011>) | +/- |  | ■■■■ | 07/11 ▶ | | | 1K2819653B | 715665 |
| Passat (93>97) | +/- | | ■■■■ | 10/93 ▶ 05/97 | 3A0819644 | 698163 | | |
| Passat (96>2000) | + | | ■■■■ | 10/96 ▶ 09/00 | 8A0819439A | 698164 | 8D0091800 | 715578 |
| Passat (2000>2005) | +/- | | ■■■■ | 10/00 ▶ | 1H0819644A | 698679 | 1H0091800 | 698686 |
| Passat (2005>) | +/- |  | ■■■■ | 03/05 ▶ | 1K0819644A | 698800 | 1K1819653A | 698801 |
| Passat (2005>) | +/- |  | ■■■■ | 03/05 ▶ | | | 1K2819653B | 715665 |
| Passat CC | +/- |  | ■■■■ | 05/08 ▶ | | | 1K2819653B | 715665 |
| Passat CC | A+ |  | ■■■■ | 05/08 ▶ | | | 1K1819653B | 698801 |
| Phaeton | A+ | x2 | ■■■■ | 05/02 ▶ | | | 3D0898644, 3D0819619A | 698793 |
| Polo (94>99) | + | | ■■■■ | 10/94 ▶ 10/99 | 1H0819644B | 698159 | 1H0091800 | 698686 |
| Polo (94>99) | +/- | w/o Plastic Frame | ■■■■ | 10/94 ▶ 10/99 | 1H0819644B | 698885 | | |
| Polo (99>2001) | +/- | | ■■■■ | 10/99 ▶ 09/01 | 1H0819644B | 698159 | 1J0819644A | 698716 |
| Polo (99>2001) | +/- | w/o Plastic Frame | ■■■■ | 10/99 ▶ 09/01 | 1H0819644B | 698885 | | |
| Polo (2001>2010) | +/- | | ■■■■ | 10/01 ▶ 05/10 | 600820367 | 698685 | 600819653 | 698739 |
| Polo (2010>) | +/- | | ■■■■ | 06/10 ▶ | 6R0820367 | 715737 | 6R0819653 | 715727 |
| Scirocco | +/- | | ■■■■ | 08/08 ▶ | 1K0819644B | 698800 | 1K1819653B | 698801 |
| Sharan (95>2000) | +/- | | ■■■■ | 08/95 ▶ 03/00 | 7M0819644 | 698247 | 7M3819644A | 698696 |
| Sharan (2000>2010) | +/- | | ■■■■ | 04/00 ▶ 07/10 | 7M0819644 | 698247 | 7M3819644A | 698696 |
| Sharan (2010>) | +/- |  | ■■■■ | 08/10 ▶ | 1K0819644 | 698800 | 1K1819653B | 698801 |
| Sharan (2010>) | +/- |  | ■■■■ | 08/10 ▶ | | | 1K2819653 | 715665 |
| Tiguan | +/- |  | ■■■■ | 09/07 ▶ | 1K0819644A | 698800 | 1K1819653A | 698801 |
| Tiguan | +/- |  | ■■■■ | 09/07 ▶ | | | 1K2819653B | 715665 |
| Touareg | +/- | | ■■■■ | 11/02 ▶ | 7H0819631 | 715581 | 7H0819631A | 698768 |
| Touareg II | + | | ■■■■ | 01/10 ▶ | | | 7P0819631 | 715704 |
| Touran | +/- |  | ■■■■ | 02/03 ▶ | 1K0819644A | 698800 | 1K1819653A | 698801 |
| Touran | +/- |  | ■■■■ | 02/03 ▶ | | | 1K2819653A | 715665 |
| Touran Heros | +/- | | ■■■■ | 05/10 ▶ | 1K0819644A | 698800 | 1K1819653A | 698801 |
| UP | +/- | | ■■■■ | 08/11 ▶ | 1S0820367 | 715744 | | |
| Vento | +/- | | ■■■■ | 11/91 ▶ 07/93 | 1H0819644B | 698160 | | |
| Vento | +/- | | ■■■■ | 11/91 ▶ 12/97 | 1H0819644B | 698159 | 1H0091800 | 698686 |
| Vento | +/- | w/o Plastic Frame | ■■■■ | 11/91 ▶ 12/97 | 1H0819644B | 698885 | | |

|  | AC |  |  |  | PA  OE Valeo | CA  OE Valeo | PCA  Valeo |
|---|-----|---|---|---|---|---|---|
| VOLKSWAGEN  | | | | | | | |
| Caddy (95>2004) | +/- | | ■ ■ ■ | 11/95 ▶ 01/04 | 1H0819644B 698159 | 1H0091800 698686 | |
| Caddy (95>2004) | +/- | w/o Plastic Frame | ■ ■ ■ | 11/95 ▶ 01/04 | 1H0819644B 698885 | | |
| Caddy (2004>) | +/- |  | ■ ■ ■ | 02/04 ▶ | 1K0819644A 698800 | | |
| Caddy (2004>) | - |  | ■ ■ ■ | 02/04 ▶ | | 1K1819653A 698801 | 701001 |
| Caddy (2004>) | + |  | ■ ■ ■ | 02/04 ▶ | | 1K2819653B 715665 | |
| Caddy IV (2010>) | +/- |  | ■ ■ ■ | 05/11 ▶ | | 1K2819653B 715665 | |
| Caddy IV (2010>) | +/- |  | ■ ■ ■ | 05/11 ▶ | 1K0819644B 698800 | 1K1819653B 698801 | 701001 |
| Caravelle | +/- | | ■ ■ ■ | 01/03 ▶ | 7H0819631 715581 | 7H0819631A 698768 | |
| Crafter | + | | ■ ■ ■ | 04/06 ▶ | 2E0819638 715601 | 2E0819638A 715602 | |
| LT (96>2003) | +/- | | ■ ■ ■ | 05/96 ▶ 04/02 | 2D0819638 698840 | | |
| LT (2003>2006) | +/- | | ■ ■ ■ | 06/03 ▶ 07/06 | 2D0819638A 698840 | | |
| Transporter (F70) (90>96) | +/- | | ■ ■ ■ | 11/92 ▶ 05/96 | 7D0819889 698794 | | |
| Transporter (F7D) (96>2003) | +/- | | ■ ■ ■ | 01/96 ▶ 06/03 | 7D0819889 698794 | | |
| Transporter (7J/7H) (2003>) | +/- | | ■ ■ ■ | 04/03 ▶ | 7H0819631 715581 | 7H0819631A 698768 | |
| VOLVO  | | | | | | | |
| 850 | +/- | | ■ ■ ■ | 06/91 ▶ 12/96 | 9171296 698770 | | |
| C30 | +/- | | ■ ■ ■ | 10/06 ▶ | 8687389 715627 | 30676484 715628 | |
| C70 (97>2006) | +/- | | ■ ■ ■ | 03/97 ▶ 12/05 | 9171296 698770 | | |
| C70 (2006>) | + | | ■ ■ ■ | 01/06 ▶ | 8687389 715627 | 30676484 715628 | |
| S40 (95>2004) | + | | ■ ■ ■ | 10/95 ▶ 03/04 | 30612666 698769 | 30883952 715676 | |
| S40 (95>2004) | + | | ■ ■ ■ | 10/95 ▶ 03/04 | 30818694 715688 | | |
| S40 (2004>) | - | | ■ ■ ■ | 03/04 ▶ | 8687389 715627 | 30676484 715628 | |
| S60 | + |  | ■ ■ ■ | 08/00 ▶ 06/10 | 9204626 698771 | 9171756 715512 | |
| S60 | + |  | ■ ■ ■ | 08/00 ▶ | | 9171757 715571 | |
| S60 II | + | | ■ ■ ■ | 07/10 ▶ | 30733894 715597 | 30733893 715702 | |
| S70 | +/- | | ■ ■ ■ | 12/96 ▶ 11/00 | 9171296 698770 | | |
| S80 | + |  | ■ ■ ■ | 06/98 ▶ 12/06 | 9204626 698771 | 9171756 715512 | |
| S80 | + |  | ■ ■ ■ | 06/98 ▶ | | 9171757 715571 | |
| S80 II | + | | ■ ■ ■ | 01/07 ▶ | 30767022 715597 | 30767024 715702 | |
| S90 | + | | ■ ■ ■ | 01/97 ▶ 12/98 | 9171296 698770 | | |
| V40 | + | | ■ ■ ■ | 10/95 ▶ 12/03 | 30612666 698769 | 30883952 715676 | |
| V40 II | + | | ■ ■ ■ | 06/12 ▶ | | 31369455 715757• | |
| V50 | +/- | | ■ ■ ■ | 03/04 ▶ | 8687389 715627 | 30676484 715628 | |
| V60 | + | | ■ ■ ■ | 07/10 ▶ | 30733894 715597 | 30733893 715702 | |
| V70 (96>99) | +/- | | ■ ■ ■ | 12/96 ▶ 12/99 | 9171296 698770 | | |
| V70 (2000>) | + |  | ■ ■ ■ | 01/00 ▶ | 9204626 698771 | 9171756 715512 | |
| V70 (2000>) | + |  | ■ ■ ■ | 01/00 ▶ | | 9171757 715571 | |
| V70 (2007>) | + | | ■ ■ ■ | 03/07 ▶ | 30767022 715597 | 30767024 715702 | |
| XC 60 | +/- | | ■ ■ ■ | 10/08 ▶ | 30733892 715597 | 30767024 715702 | |
| XC 70 | +/- |  | ■ ■ ■ | 09/02 ▶ | | 9171757 715571 | |
| XC 70 | + |  | ■ ■ ■ | 09/02 ▶ | 9204626 698771 | 9171756 715512 | |

|  | AC |  |  |  | PA    | CA    | PCA   | |
|--|-----|---|---|---|--|--|---|---------------|
| VOLVO  (.../...) | | | | | | | | |
| XC 70 (2007>) | + | | ■■■ | 03/07 ▶ | 30767022 | 715597 | 30733893 | 715702 |
| XC 90 (2002>) | +/- |  | ■■■ | 05/02 ▶ | 9204626 | 698771 | 9171756 | 715512 |
| XC 90 (2002>) | A+ |  | ■■■ | 05/02 ▶ | | | 9171757 | 715571 |
| | | | | | | | | |

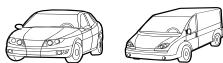



CLIM PUR'

Air conditioning cleaner

Nettoyant climatisation
 Klimasystem-reiniger
 Limpiador del climatizador
 Limpador de ar condicionado
 Detergente climatizzazione
 Air conditioning reiniger
 Środek czyszczący
 do klimatyzacji
 Очиститель системы
 кондиционирования воздуха
 Čistič prostředek
 pro klimatizace
 Sredstvo za čišćenje
 klimatizacije
 Klímaberendezés tisztító spray
 Curățitor de aer condiționat
 Klima temizleyici
 ΚΑΘΑΡΙΣΤΙΚΟ ΚΛΙΜΑΤΙΣΤΙΚΟΥ



Clim pur' display

Presentoir clim pur'
 Clim pur' display
 Expositor clim pur'
 Display clim pur'
 Confezione climatizzatore
 Display clim pur'
 Clim pur displej
 Дисплей для clim pur
 Clim pur na prodajnom
 nosaču
 Klímaberendezés tisztító
 spray bemutató tartón
 Afisare clim pur'
 Clim pur дисплей
 Clim pur' sergileme ünitesi
 Εκθέτης CLIM PUR'

**Valeo**

Qty

**698984 CLIM PUR'****1****Valeo**

Qty

**698985 CLIM PUR' (698984) x15**

Think about using Clim PUR' at each cabin filter change

Pensez à utiliser Clim PUR' à chaque changement du filtre habitacle

Verwenden Sie Climpur' bei jedem Wechsel des Innenraumluftfilters

Piense en utilizar Clim PUR' en cada cambio de Filtro de Habitáculo

Use o «ClimPur» a cada substituição do filtro de habitáculo

Ricordatevi di utilizzare il «Clim Pur» ad ogni sostituzione del filtro abitacolo

Denk ook aan het gebruik van de «Clim Pur» bij iedere vervanging van het interieurfilter

Sugerowane stosowanie «ClimPur» przy każdorazowej wymianie filtra kabionowego

Рекомендуется использовать ClimPur при каждой замене салонного фильтра

Používejte CLIM PUR' při každé výměně kabinového filtru

Upotrebľavajte «Clim Pur» priľikom svake izmjene filtera kabine

Minden pollenszűrőcsere során használjon Clim Pur-t.

Nu uitați să utilizați Clim Pur' la fiecare schimb de filtru

Помислете за ползите от подмяната на всеки филтър купе

Kabin filterisi değişimlerinde «ClimPur» kullanılması gerektiğini dikkate alınız

Σκεφτείτε τη χρήση του Clim Pur', με την αλλαγή κάθε φίλτρου καμπίνας

Valeo

Qty

**698991 CLIM PUR'
Workshops/Ateliers****20**



CLIM SPRAY

Cabin cleaner

Purifiant habitacle
 Innenraum-luft-reiniger
 Purificador de aire del habitáculo
 Purificador do ar do habitáculo
 Detergente abitacolo
 Interieur verfrisser
 Odświeżacz kabinowy
 Очиститель воздуха
 Čistač kabine vozila
 Čistič interiéru vozu
 Utastér légtisztító spray
 Purificator habitaculu
 Почистващ въздуха на купето препарат
 Kabin hava temizleyicisi
 ΚΑΘΑΡΙΣΤΙΚΟ ΚΑΜΠΙΝΑΣ



Clim spray display

Presentoir clim spray
 Display clim spray
 Clim spray display
 Expositor clim spray
 Confezione clim spray
 Display clim spray
 Clim spray displej
 Дисплей для clim spray
 Clim spray na prodajnom nosaču
 Utastér légtisztító spray bemutató tartón
 Afişare clim spray
 Clim spray дисплей
 Clim spray sergileme ünitesi
 Εκθέτης CLIM SPRAY



| | | |
|---------------|-------------------|----------|
| | | |
| 698899 | CLIM SPRAY | 1 |

| | | |
|---------------|-------------------|---------------------|
| | | |
| 715899 | CLIM SPRAY | (698899) x15 |

Think about using clim spray every 6 months

Pensez a utiliser clim spray tous les 6 mois
 Denken sie daran, climspray alle 6 monate zu benutzen
 Recomendamos la utilización del clim spray cada 6 meses
 Recomendamos a utilização do clim spray a cada 6 meses
 Si consiglia l'utilizzo del clim spray ogni 6 mesi
 Denk er aan: gebruik clim spray om de 6 maanden !!!!!
 Pamiętaj aby używać climspray co 6 miesięcy
 Clim spray рекомендуется использовать каждые 6 месяцев
 Používejte clim spray každých 6 měsíců
 Preporučamo koristiti clim spray svakih 6 mjeseci
 Ajánlatos a clim spray-t rendszeresen, 6 havonta használni
 Nu uitati sa utilizati clim spray la fiecare 6 luni
 Помислете за ползите от използването на спрей за почистване на всеки 6 месеца
 6 Ayda bir clim spray kullanmayi unutmayiniz
 Σκεφτείτε τη χρήση του Clim Spray κάθε 6 μήνες



| | | |
|---------------|--|-----------|
| | | |
| 715991 | CLIM SPRAY Workshops/Ateliers | 20 |



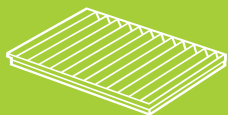
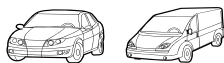

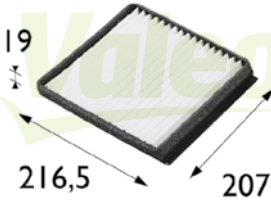
698146**PA**

CITROËN
CITROËN
CITROËN
PEUGEOT
PEUGEOT

Berlingo
Xantia
Xsara
Partner
Ranch

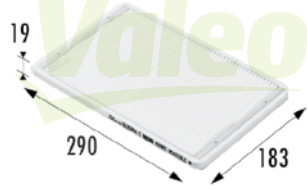
698149**PA**

RENAULT

Mégane (95>99)

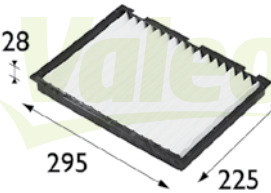
698159**PA**

AUDI
SEAT
SEAT
SKODA
VOLKSWAGEN
VOLKSWAGEN

A3
Arosa, Cordoba, Ibiza
Inca, Leon, Toledo
Octavia, Superb
Caddy, Golf III, Lupo
Polo (94>2001), Vento

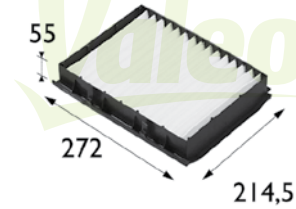
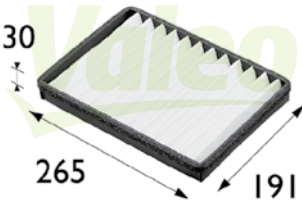
698160**PA**VOLKSWAGEN
VOLKSWAGENGolf III (91>97)
Vento**698163****PA**

VOLKSWAGEN

Passat (93>97)

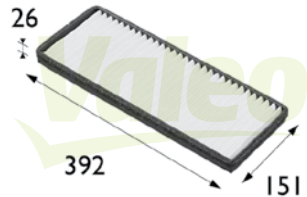
698164**PA**

AUDI
AUDI
AUDI
AUDI
AUDI
VOLKSWAGEN

80 (91>95), 90 (91>95)
A4 (94>2000), S4 (97>99)
Cabriolet
Coupé (88>96)
RS4 Quattro
Passat (96>2000)

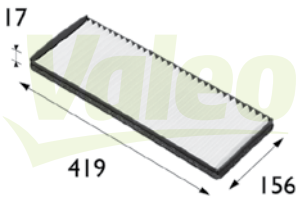
698165**PA**

| | |
|----------|------------------|
| OPEL | Astra F, Astra G |
| OPEL | Calibra |
| OPEL | Corsa B, Tigra |
| VAUXHALL | Astra III |
| VAUXHALL | Calibra |
| VAUXHALL | Corsa I, Tigra |

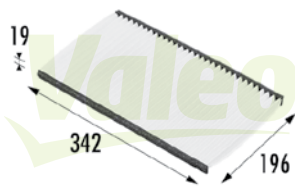
698166**PA**

| | |
|----------|---------|
| OPEL | Combo |
| OPEL | Corsa B |
| OPEL | Tigra |
| VAUXHALL | Combo |
| VAUXHALL | Corsa I |
| VAUXHALL | Tigra |

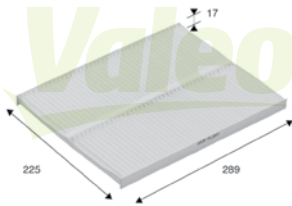
698167**PA**

| | |
|----------|---------|
| OPEL | Omega B |
| VAUXHALL | Omega |

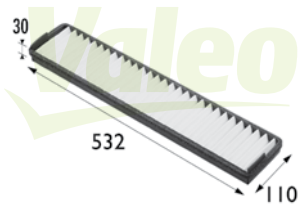
698168**PA**

| | |
|------|--------|
| FORD | Cougar |
| FORD | Mondeo |

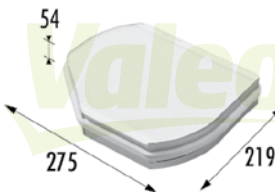
698169**PA**

| | |
|----------|---------------|
| MERCEDES | C Class (202) |
| MERCEDES | CLK (208) |
| MERCEDES | E Class (210) |
| MERCEDES | S Class (220) |
| MERCEDES | SLK (170) |

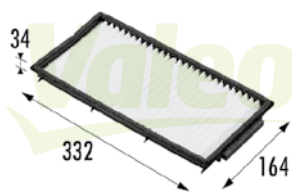
698170**PA**

| | |
|-----|--------------|
| BMW | 5 series E34 |
| BMW | 7 series E32 |
| BMW | M5 E34 |

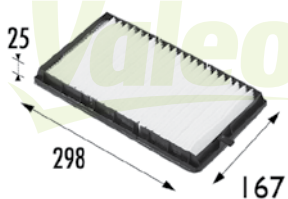
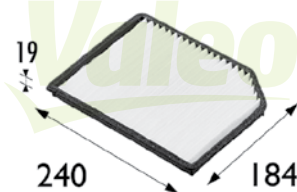
698171**PA**BMW
BMW3 series E36
M3 E36**698173****PA**

RENAULT

Laguna

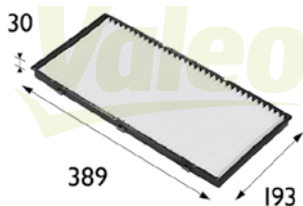
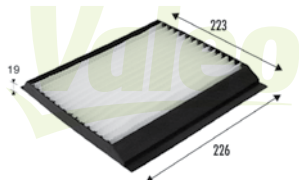
698174**PA**ALFA ROMEO 145, 146, 155, GTV, Spider
FIAT Coupe, Tempra, Tipo
LANCIA Dedra, Delta (93>99)**698175****PA**

RENAULT

Mégane Scénic

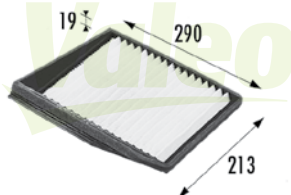
698176**PA**

RENAULT

Mégane Scénic

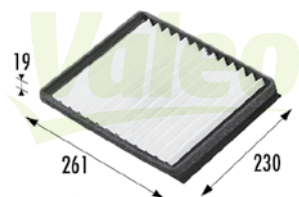
698177**PA**

RENAULT

Mégane Scénic

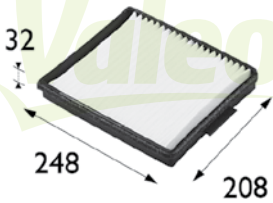
698196**PA**

| | |
|-------|-------------------|
| HONDA | Civic V (95>2001) |
| MG | ZR, ZS |
| ROVER | 200, 400, 25, 45 |
| ROVER | Streetwise |

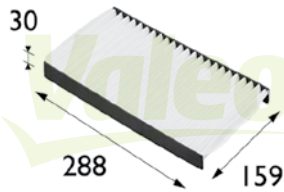
698197**PA**

| | |
|------------|---------------|
| ALFA ROMEO | 156 |
| FIAT | Brava/o |
| FIAT | Marea |
| FIAT | Marengo (185) |
| LANCIA | Debra |
| LANCIA | Lybra |

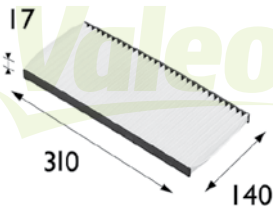
698198**PA**

| | |
|--------|---------------------|
| FIAT | Punto (93>99) |
| LANCIA | Y Ipsilon (95>2000) |

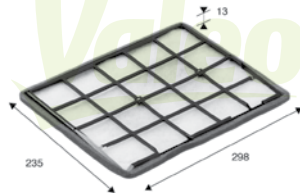
698199**PA**

| | |
|------------|-------|
| ALFA ROMEO | 164 |
| FIAT | Croma |
| LANCIA | Thema |
| SAAB | 9000 |

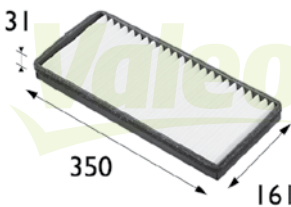
698201**PA**

| | |
|-------|------------------|
| FORD | Courier (96>) |
| FORD | Fiesta (95>2002) |
| FORD | Ka, StreetKa |
| FORD | Puma |
| MAZDA | 121 |

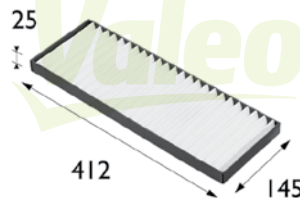
698202**PA**

| | |
|----------|------------------|
| OPEL | Vectra B |
| VAUXHALL | Vectra (95>2002) |

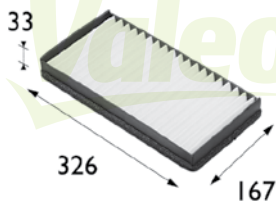
698203**PA**

PEUGEOT 406
 PORSCHE 911
 PORSCHE Boxster (986)

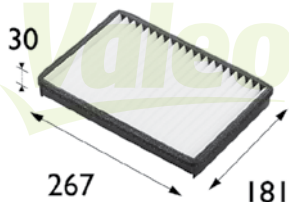
698235**PA**

PEUGEOT 405 (92>96)

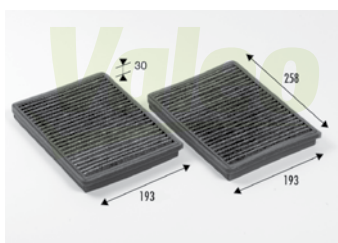
698246**CA**

BMW 5 series E39
 BMW M5 E39

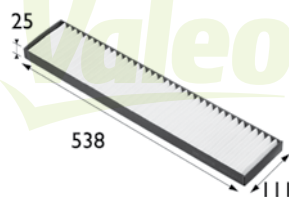
698247**PA**

FORD Galaxy
 SEAT Alhambra
 VOLKSWAGEN Sharan

698255**PA**

NISSAN Kubistar
 RENAULT Clio II,
 Clio Campus Evolution (2009>)
 RENAULT Kangoo
 RENAULT Mégane

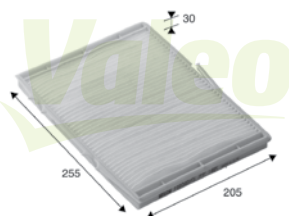
698276**PA**

RENAULT Mégane

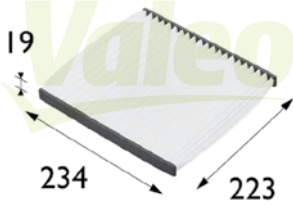
698279**PA**

RENAULT

Mégane Scénic

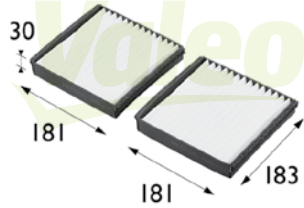
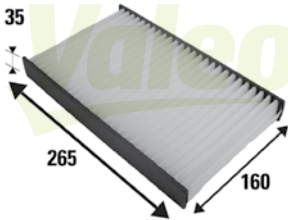
698290**PA**RENAULT
RENAULTAvantime
Espace III**698454****PA**

FIAT

Multipla

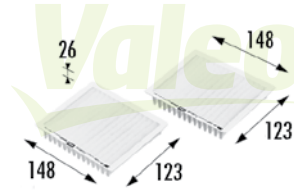
698469**PA**

BMW

3 series E36 Compact

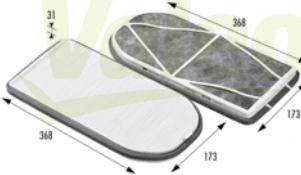
698470**CA**

BMW

7 series E38

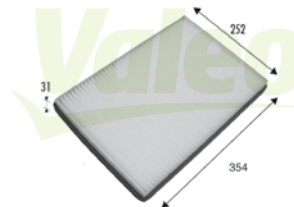
698475**PA**MERCEDES
MERCEDESA Class (168)
Vaneo (414)

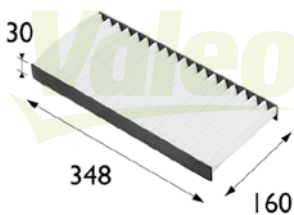
698487**PA**

FORD
FORD
FORD

Focus
Tourneo Connect
Transit Connect

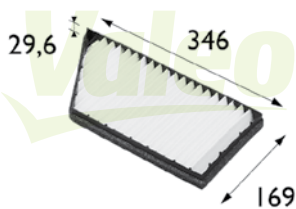
698488**PA**

PEUGEOT

206, 206 CC

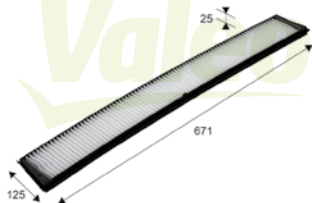
698489**PA**

BMW
BMW

3 series E46
X3

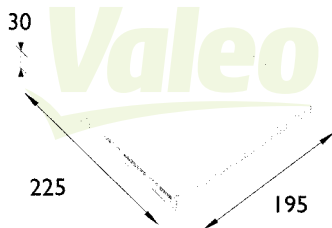
698512**PA**

RENAULT

Mégane Scénic

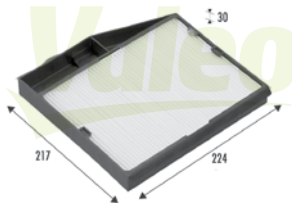
698535**PA**

FIAT
FIAT

Doblo
Punto II

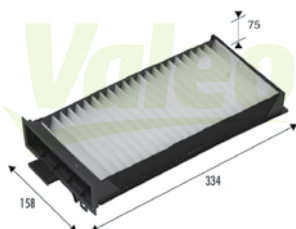
698540**PA**

CITROËN

C5 (2001>2004)

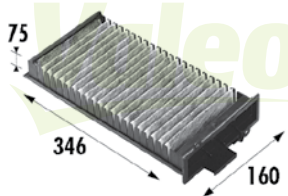
698541**CA**

CITROËN

C5 (2001>2004)

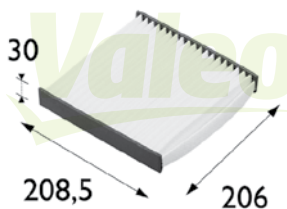
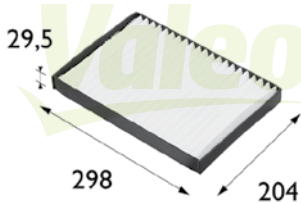
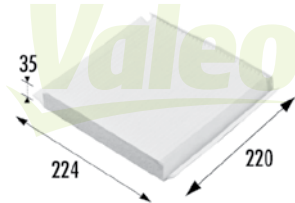
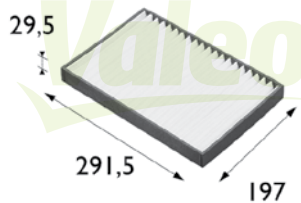
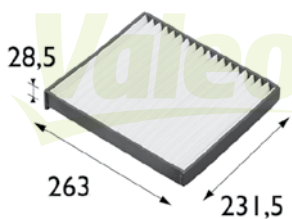
698594**PA**RENAULT
RENAULTLaguna II
Vel Satis**698606****PA**AUDI
AUDI
AUDI
SEATA4 (2000>)
A6 (97>2001)
S4 (2003>)
Exeo**698657****PA**CITROËN
CITROËN
PEUGEOT
PEUGEOTBerlingo
Xsara (2000>)
Partner
Ranch**698662****PA**OPEL
VAUXHALLAstra G
Astra IV**698663****PA**OPEL
OPEL
VAUXHALLAstra G
Zafira
Zafira

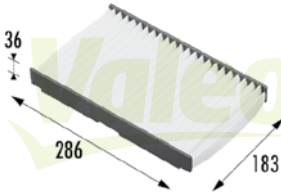
698664**PA**

| | |
|---------|----------------|
| CITROËN | C2 |
| CITROËN | C3, C3 Pluriel |
| CITROËN | C4, C4 II |
| CITROËN | DS4 |
| PEUGEOT | 307 |
| PEUGEOT | 1007 |
| PEUGEOT | 308 |

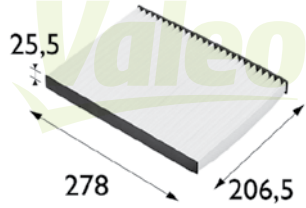
698679**PA**

VOLKSWAGEN

Passat (2000>)

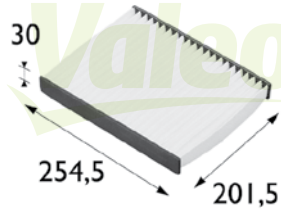
698680**PA**

CITROËN

Xsara Picasso

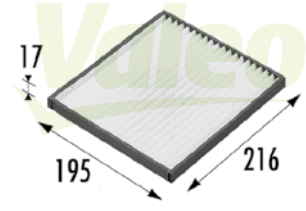
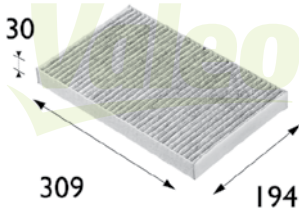
698681**PA**TOYOTA
TOYOTA
TOYOTARAV4 (2000>)
Yaris JPP
Yaris Verso**698682****CA**

AUDI

A6 (97>2001)

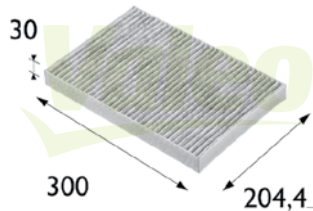
698683**CA**AUDI
AUDI
AUDI
AUDI
SEATA4 (2000>)
A6 (97>2004)
A6 Allroad
S6 (99>)
Exeo

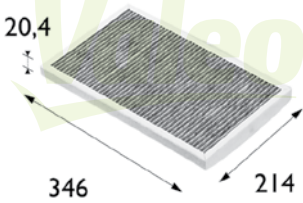
698684**CA**

| | |
|------|--------------|
| AUDI | 100 (90>94) |
| AUDI | A6 (94>97) |
| AUDI | S4 (99>2001) |

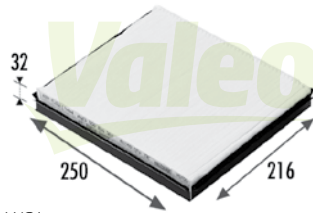
698685**PA**

| | |
|------------|-----------------|
| AUDI | A2 |
| SEAT | Cordoba (2002>) |
| SEAT | Ibiza (2001>) |
| SKODA | Fabia |
| VOLKSWAGEN | Fox |
| VOLKSWAGEN | Polo (2001>) |

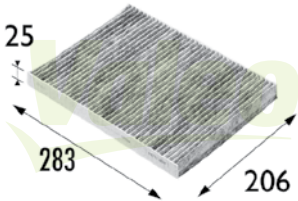
698686**CA**

| | |
|------------|-----------------------|
| AUDI | A3 |
| SEAT | Arosa, Cordoba, Ibiza |
| SEAT | Toledo (98>) |
| SKODA | Octavia (96>2004) |
| VOLKSWAGEN | Caddy, Golf III |
| VOLKSWAGEN | Passat (2000>) |
| VOLKSWAGEN | Polo (94>99), Vento |

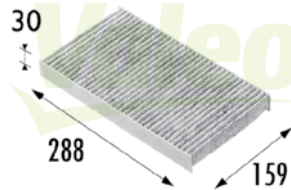
698687**CA**

| | |
|------------|----------------|
| ALFA ROMEO | 156 |
| FIAT | Brava/o, Marea |
| LANCIA | Dedra, Lybra |

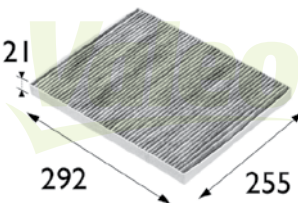
698688**CA**

| | |
|------------|---------------|
| ALFA ROMEO | 166 |
| LANCIA | Kappa |
| MASERATI | 3200GT |
| MASERATI | Coupe, Spider |

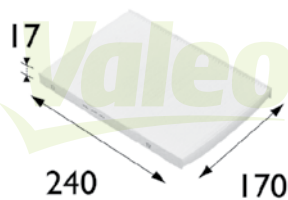
698689**PA**

| | |
|------------|---------------|
| ALFA ROMEO | 156 |
| FIAT | Brava/o |
| FIAT | Marea |
| FIAT | Marengo (185) |

698690

PA

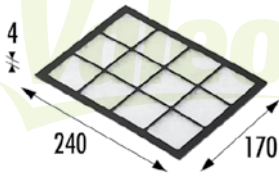

FIAT
FIAT

Palio, Siena
Strada Pick Up

698691

PA

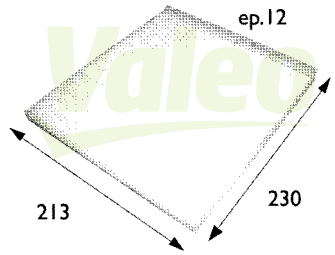

FIAT
FIAT

Palio
Siena

698692

CA

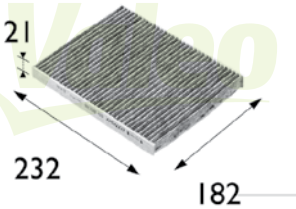

FIAT

Stilo

698693

CA

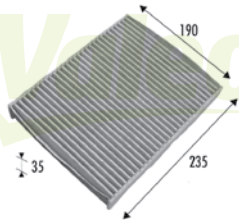

FORD
FORD

Fiesta (2002>)
Fusion

698694

PA

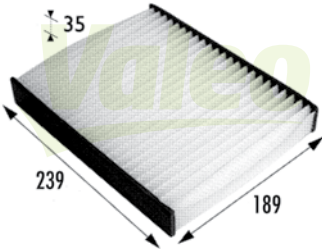

FORD
FORD
FORD

Fiesta (2002>)
Fusion

698695

CA

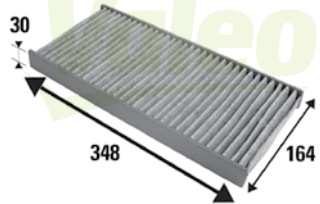

FORD
FORD
FORD

Focus
Tourneo Connect
Transit Connect

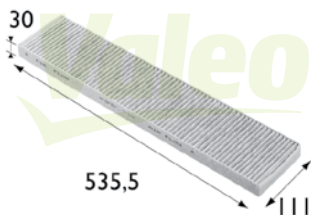
698696**CA**

FORD
SEAT
VOLKSWAGEN

Galaxy
Alhambra
Sharan

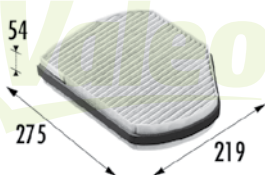
698697**CA**

CHRYSLER
MERCEDES
MERCEDES
MERCEDES
MERCEDES

Crossfire
C Class (202)
CLK (208)
E Class (210)
SLK (170)

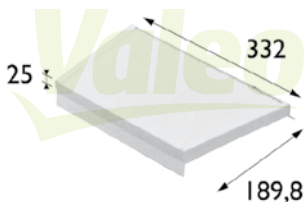
698700**PA**

MERCEDES
MERCEDES

C Class (203)
CLK (209)

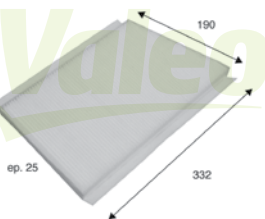
698701**PA**

MERCEDES
MERCEDES

C Class (203)
CLK (209)

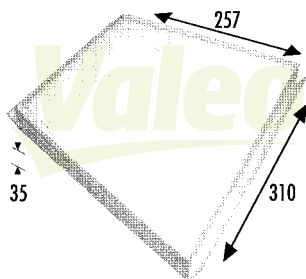
698702**PA**

MERCEDES
MERCEDES

CLS (219)
E Class (211)

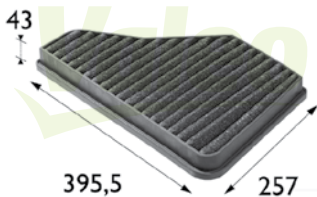
698703**CA**

MERCEDES

S Class (140)

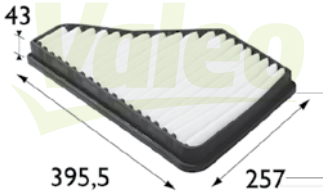
698704**PA**

MERCEDES

S Class (140)

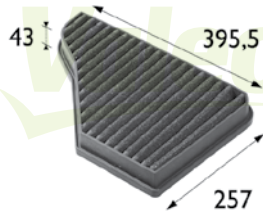
698705**CA**

MERCEDES

S Class (140)

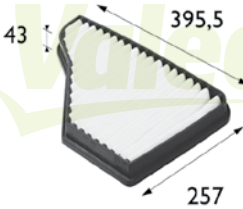
698706**PA**

MERCEDES

S Class (140)

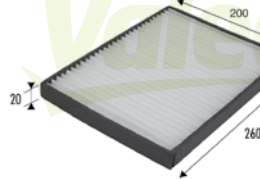
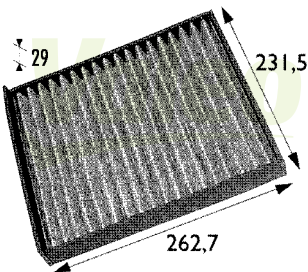
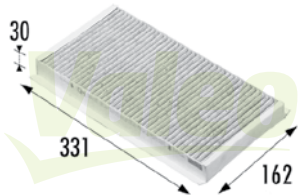
698707**PA**FORD
NISSAN
NISSANMaverick (93>98)
Primera (P11)
Terrano II (93>2001)**698708****CA**OPEL
OPEL
VAUXHALL
VAUXHALLAstra G
Zafira
Astra IV
Zafira**698710****CA**FIAT
OPEL
OPEL
OPEL
SAAB
VAUXHALL
VAUXHALL
VAUXHALLCroma II (2005>)
Corsa C, Signum
Tigra Twintop
Vectra C
9-3
Corsa II, Signum
Tigra Twintop
Vectra (2002>)

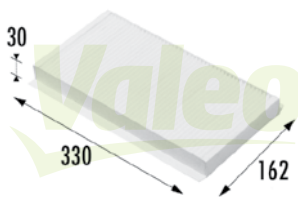
698711**PA**

CADILLAC
 OPEL
 OPEL
 OPEL
 SAAB
 VAUXHALL
 VAUXHALL
 VAUXHALL

BLS
 Corsa C, Signum
 Tigra Twintop
 Vectra C (2002>)
 9-3
 Corsa II, Signum
 Tigra Twintop
 Vectra (2002>)

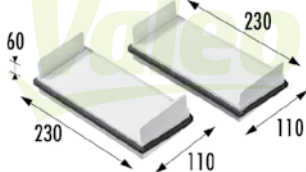
698712**PA**

OPEL
 VAUXHALL

Sintra
 Sintra

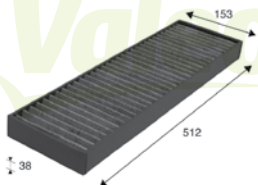
698713**CA**

PEUGEOT

607

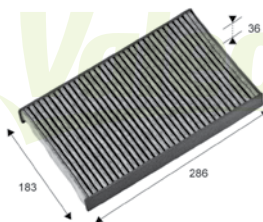
698714**CA**

CITROËN
 CITROËN
 CITROËN
 PEUGEOT
 PEUGEOT

C2
 C3, C3 Pluriel
 C4, C4 II, DS4
 307, 308
 1007, Rcz

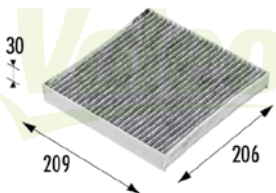
698715**CA**

RENAULT
 RENAULT

Laguna II
 Vel Satis

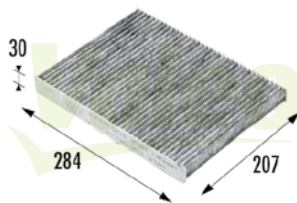
698716**CA**

AUDI
 SEAT
 SKODA
 VOLKSWAGEN
 VOLKSWAGEN
 VOLKSWAGEN
 VOLKSWAGEN

A3, S3, TT
 Arosa, Leon
 Octavia (2000>2004)
 Bora
 Golf IV (97>2003)
 Lupo, New Beetle
 Polo (99>2001)

698723

CA

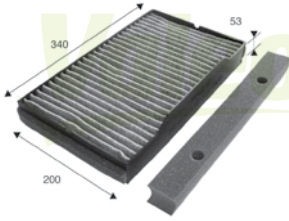

SAAB

9-5

698724

PA

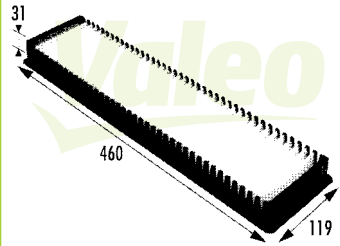

MINI

Mini

698725

CA

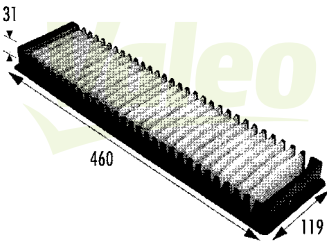

MINI

Mini

698730

PA

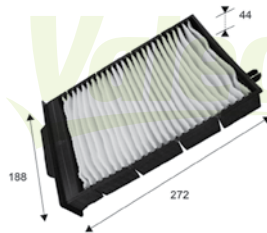

RENAULT

Mégane II

698731

PA

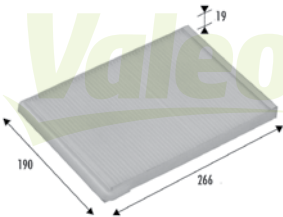

CITROËN

Xsara

698734

PA

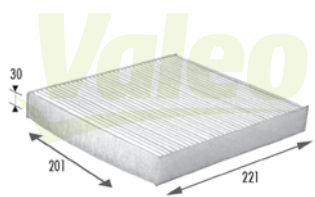

NISSAN
NISSAN
NISSAN

Almera
Almera Tino
Primera (P12)

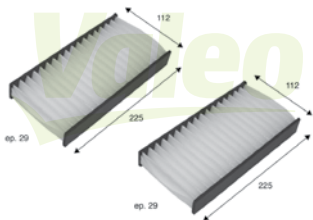
698735**PA**

HONDA
HONDA

Civic (2001>)
CR-V (2002>)

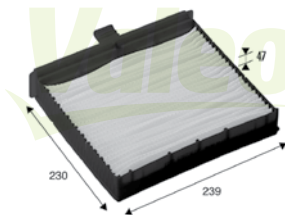
698736**PA**

RENAULT

Scénic II

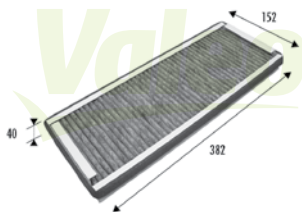
698737**CA**

RENAULT

Espace IV (2002>)

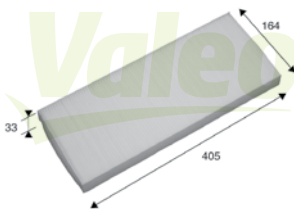
698738**PA**

CITROËN
FIAT

C8, Jumpy I
Ulysse (2002>),
Scudo (2004>2006)

LANCIA
PEUGEOT

Phedra
807, Expert I

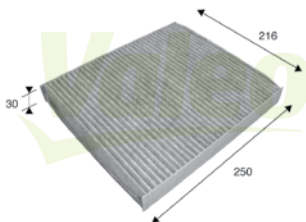
698739**CA**

AUDI
SEAT
SEAT
SKODA
VOLKSWAGEN
VOLKSWAGEN

A2
Cordoba (2002>)
Ibiza (2001>)
Fabia
Fox
Polo (2001>)

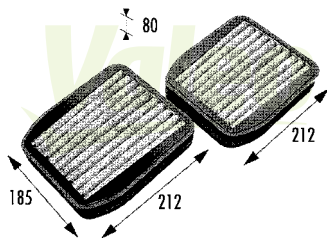
698740**CA**

MERCEDES
MERCEDES

CLS (219)
E Class (211)

698741

CA

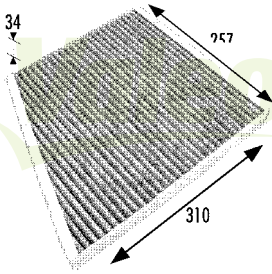

MERCEDES
MERCEDES

CLS (219)
E Class (211)

698742

CA

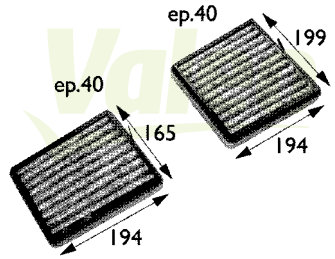

MERCEDES

C Class (203)

698743

CA

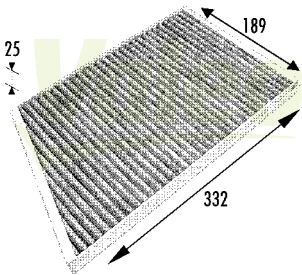

MERCEDES

C Class (203)

698744

CA

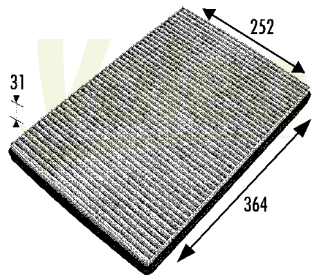

MERCEDES

A Class (168)

698745

CA

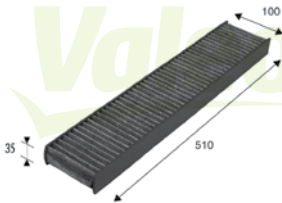

FORD
JAGUAR

Mondeo (2000>)
X-Type

698746

CA

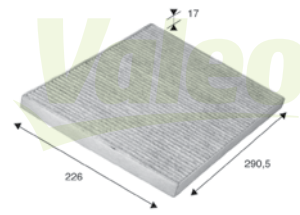

OPEL
VAUXHALL

Omega B (94>)
Omega

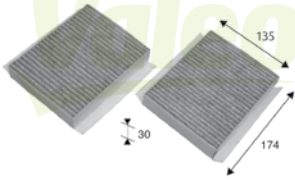
698747**CA**

ALFA ROMEO
ALFA ROMEO
ALFA ROMEO

147
156
GT

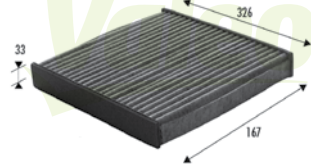
698748**CA**

PEUGEOT
PORSCHE
PORSCHE

406
911
Boxster (986)

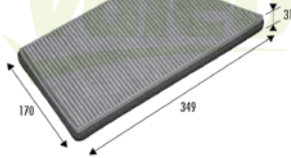
698749**CA**

PEUGEOT

206, 206 CC

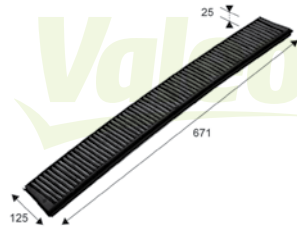
698750**CA**

BMW
BMW
BMW

3 series E46
M3 E46
X3

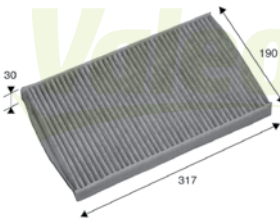
698751**CA**

LANCIA

Thesis

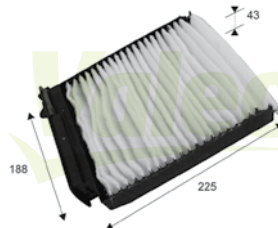
698753**PA**

DACIA
NISSAN
NISSAN
RENAULT
RENAULT
RENAULT

Lodgy, Logan, Sandero
Micra (K12)
Note
Clio III
Modus
Twingo (2007->)

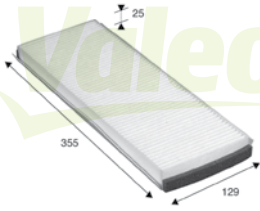
698762**PA**

FORD

Transit (2000>)

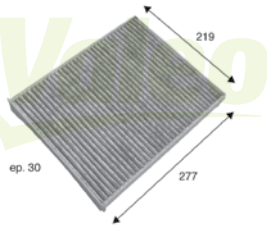
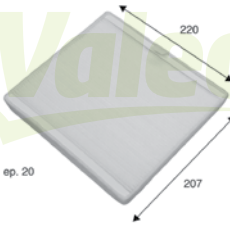
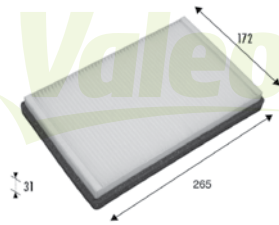
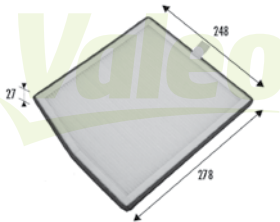
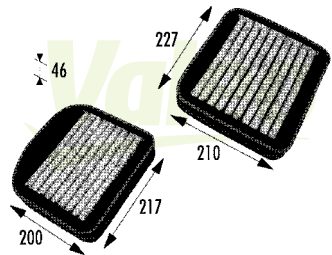
698768**CA**AUDI
PORSCHE
VOLKSWAGEN
VOLKSWAGENQ7
Cayenne
Touareg
Transporter (2003>)**698769****PA**VOLVO
VOLVOS40
V40**698770****PA**VOLVO
VOLVO
VOLVO
VOLVO850
C70
S70, S90
V70 (96>99)**698771****PA**VOLVO
VOLVO
VOLVO
VOLVO
VOLVOS60
S80
V70 (2000>)
XC 70
XC 90**698772****CA**MAYBACH
MERCEDES
MERCEDES
MERCEDESMaybach 57/62
CL Class (215)
E Class (210)
S Class (220)

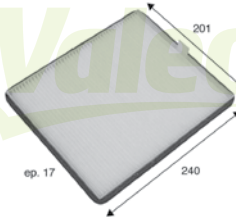
698773**PA**

OPEL
SUBARU
SUZUKI
SUZUKI
VAUXHALL

Agila
Justy (2003>)
Ignis
Wagon R+
Agila

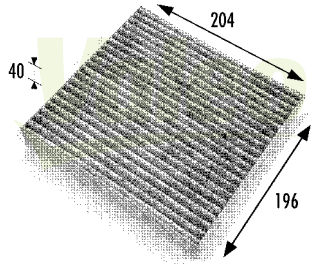
698774**CA**

SMART
SMART
SMART

Crossblade
Fortwo
Smart

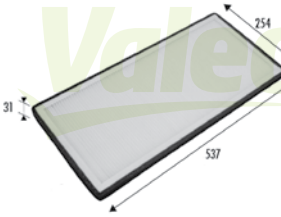
698775**PA**

BMW X5
LAND ROVER Range Rover (2002>)

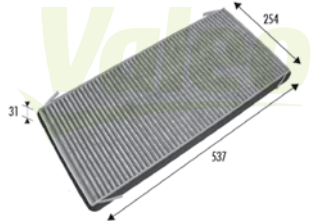
698776**CA**

BMW X5
LAND ROVER Range Rover (2002>)

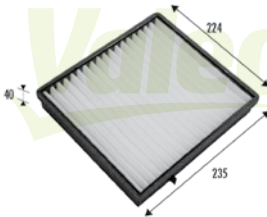
698777**PA**

MERCEDES ML Class (163)

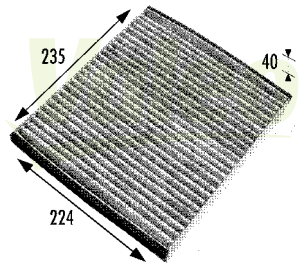
698778**CA**

MERCEDES ML Class (163)

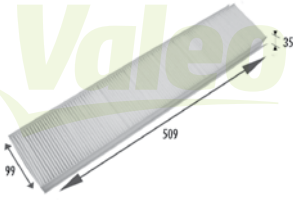
698779**PA**

FORD
JAGUAR

Mondeo (2000>)
X-Type

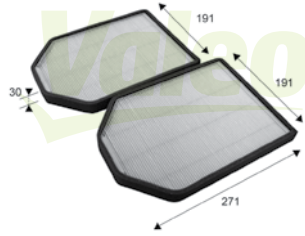
698790**PA**

AUDI

A8 (94>2002)

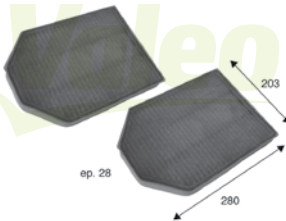
698791**CA**

AUDI

A8 (94>2002)

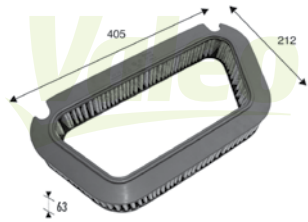
698792**CA**

AUDI

A8 (2002>)

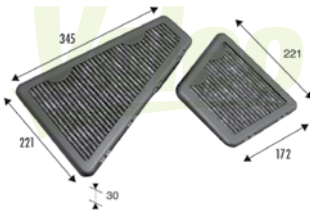
698793**CA**

BENTLEY
BENTLEY
VOLKSWAGEN

Continental Flying Spur
Continental GT, GTC
Phaeton

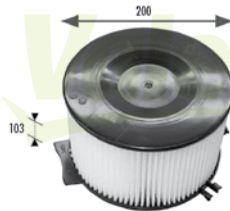
698794**PA**

VOLKSWAGEN

Transporter (90>2003)

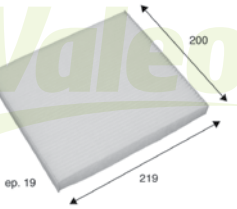
698795**PA**

TOYOTA Avensis
 TOYOTA Corolla (120) (2001>)
 TOYOTA Corolla Verso

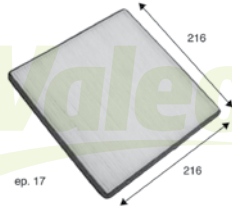
698796**PA**

SUBARU Legacy (2003>)
 TOYOTA Avensis Verso
 TOYOTA Celta (99>)
 TOYOTA Land Cruiser (2002>)
 TOYOTA Previa (2000>)
 TOYOTA Prius
 TOYOTA Yaris

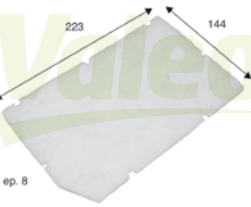
698797**PA**

MERCEDES S Class (140)

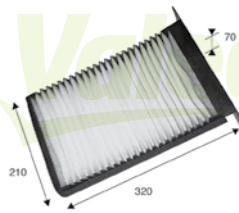
698799**PA**

LAND ROVER Freelander

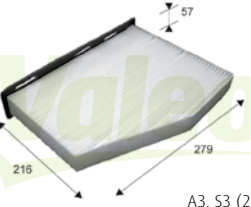
698800**PA**

AUDI A3, S3 (2006>)
 SEAT Alhambra III (2010>), Altea, Leon II
 SEAT Toledo (2004>)
 SKODA Octavia (2004>), Superb, Yeti
 VOLKSWAGEN Caddy (2004>)
 VOLKSWAGEN Golf V, Golf Plus
 VOLKSWAGEN Jetta (2005>), Passat VII
 VOLKSWAGEN New Beetle (2011>)
 VOLKSWAGEN Scirocco, Sharan III
 VOLKSWAGEN Tiguan, Touran, Touran Héros

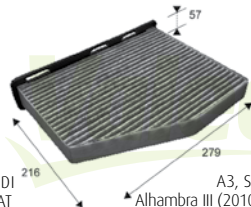
698801**CA**

AUDI A3, S3 (2006>)
 SEAT Alhambra III (2010>), Leon II
 SKODA Octavia (2004>)
 SKODA Superb
 VOLKSWAGEN Caddy (2004>)
 VOLKSWAGEN Golf V, Golf Plus
 VOLKSWAGEN Jetta (2005>), Passat VII
 VOLKSWAGEN New Beetle (2011>)
 VOLKSWAGEN Scirocco, Sharan III
 VOLKSWAGEN Tiguan, Touran, Touran Héros
 VOLKSWAGEN Touran

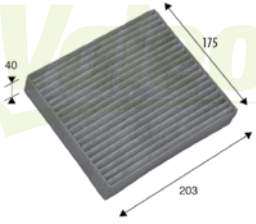
698802**CA**

SMART
SMART
MITSUBISHI

Forfour
Roadster
Colt (2005>)

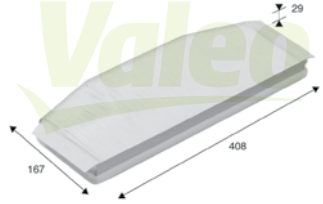
698815**PA**

PEUGEOT

605 (94>99)

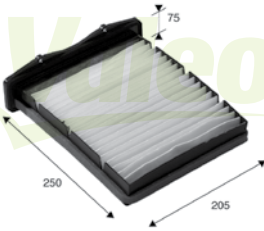
698817**PA**

LAND ROVER

Freelander

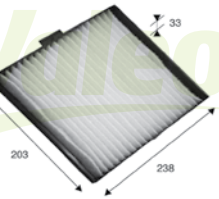
698819**PA**

MG
ROVER
ROVER

ZS
45
400 (95>)

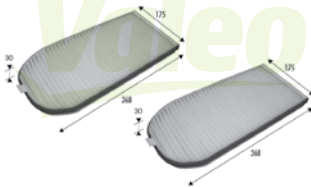
698838**PA**

BMW

7 series E38

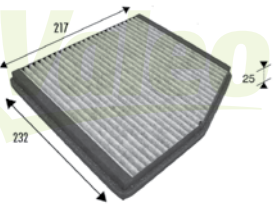
698839**CA**

FIAT
FIAT

Doblo
Punto II

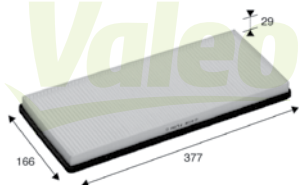
698840**PA**

MERCEDES

Sprinter (95>)

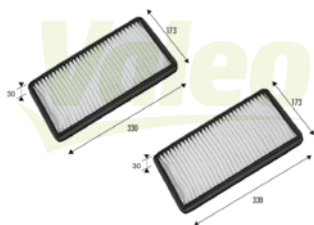
698856**PA**

BMW

7 series E65/E66

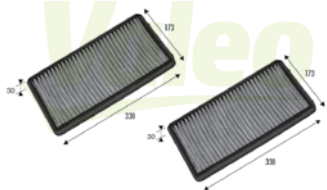
698857**CA**

BMW

7 series E65/E66

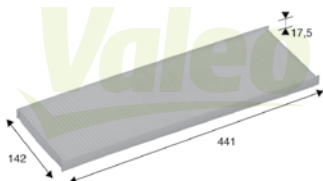
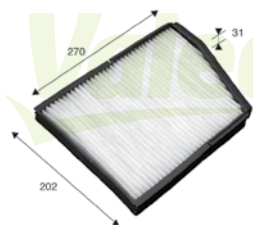
698858**PA**CITROËN
CITROËN
FIAT
PEUGEOTJumper
Relay (94>2001)
Ducato
Boxer (2002>)**698859****PA**

DAEWOO

Leganza

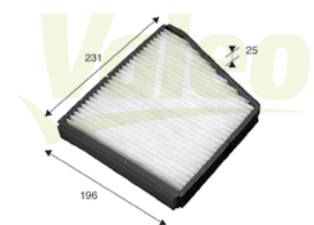
698860**PA**CHEVROLET
DAEWOONubira
Nubira

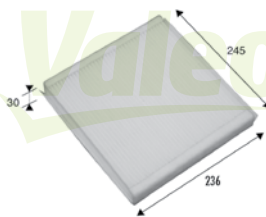
698861**PA**

BMW

Z4

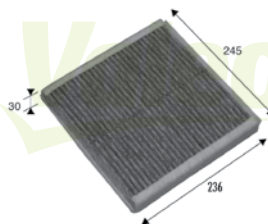
698862**CA**

BMW

Z4

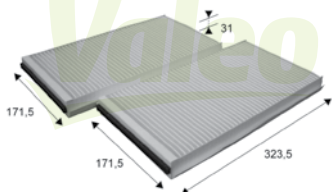
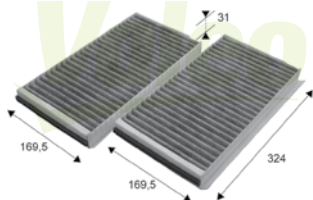
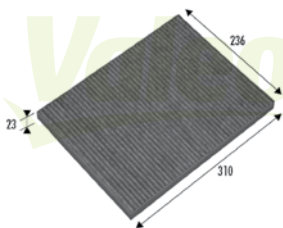
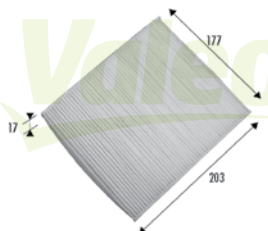
698863**PA**BMW
BMW5 series E60/E61
6 series E63/E64**698864****CA**BMW
BMW5 series E60/E61
6 series E63/E64**698865****CA**CHRYSLER
CHRYSLER
CHRYSLERGrand Voyager (2004>)
Voyager (2001>2004)
Voyager (2004>)**698866****PA**ABARTH
FIAT
FORDNuova 500
Panda (2003>), 500, 500C
Ka (2008>)

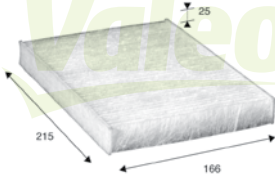
698867**PA**

FIAT
FIAT
FIAT
LANCIA
LANCIA

Doblo
Idea
Punto II
Musa
Ypsilon

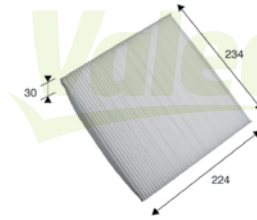
698868**PA**

HONDA
HONDA

Accord VIII (2003-
Ridgeline

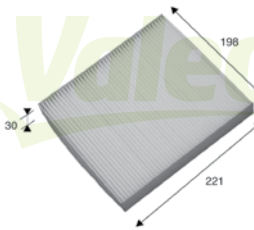
698869**PA**

HONDA
HONDA
HONDA
ROVER

Civic Aerodeck (97-
Civic V (95>2001)
CR-V (97>2002)
400 (95-)

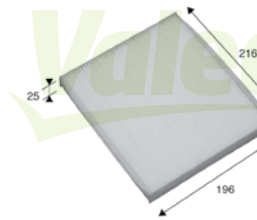
698870**PA**

MAZDA

6 (2002-)

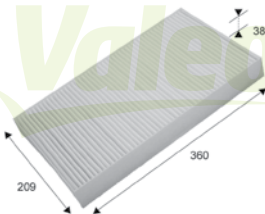
698871**PA**

MERCEDES

Viano

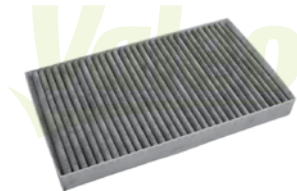
698872**CA**

MERCEDES

Viano

698873

CA

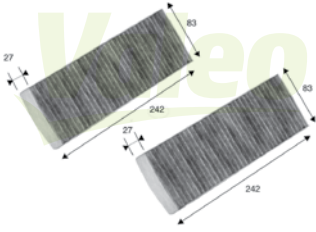

INFINITI
NISSAN

I 30, I 35
Maxima QX (A33)

698874

PA

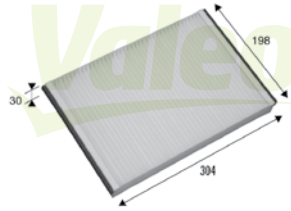

OPEL
VAUXHALL

Astra H (2004>)
Astra (2004>)

698875

CA

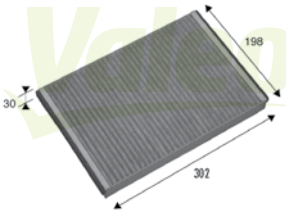

OPEL
VAUXHALL

Astra G, Astra H (2004>)
Astra IV

698876

PA

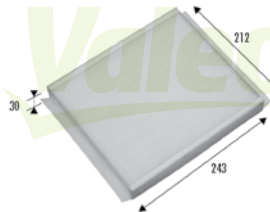

OPEL
VAUXHALL

Meriva
Meriva

698877

CA

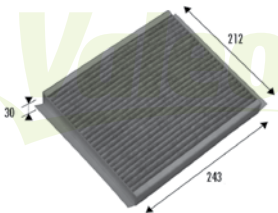

OPEL
VAUXHALL

Meriva
Meriva

698878

PA

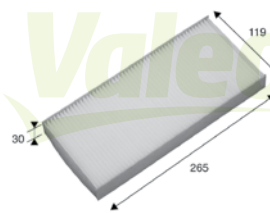

RENAULT

Twingo

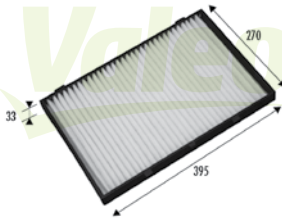
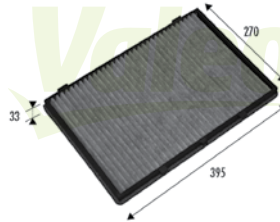
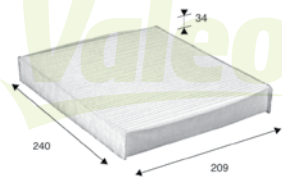
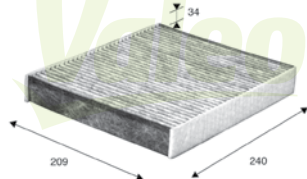
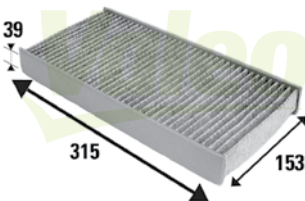
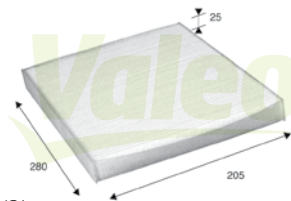
698879**PA**MG
ROVERZT
75**698880****PA**MG
ROVERZT
75**698882****PA**FORD Focus C-Max, Galaxy (2006>)
FORD Kuga, Mondeo (2007>), S-Max**698883****CA**FORD Focus C-MAX, Galaxy (2006>)
FORD Kuga, Mondeo (2007>), S-Max**698884****CA**CITROËN C5 (2004>)
CITROËN C6
PEUGEOT 407, 407 Coupé**698885****PA**AUDI A3
SEAT Arosa, Cordoba, Ibiza
SEAT Inca, Leon, Toledo
SKODA Octavia, Superb
VOLKSWAGEN Caddy, Golf III
VOLKSWAGEN Lupo, Polo (94>2001)
VOLKSWAGEN Vento

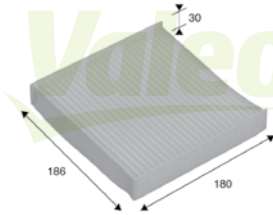
698886**PA**

FIAT
HONDA
SUZUKI

Sedici
Jazz (2002>)
Swift (2005>)

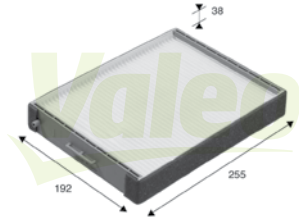
698888**PA**

HYUNDAI
HYUNDAI
HYUNDAI
HYUNDAI
KIA
KIA
KIA

Santa Fe
Sonata
Trajet
XG
Magentis
Optima
Sorento

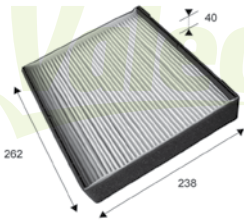
698889**PA**

KIA

Opirus, Amanti

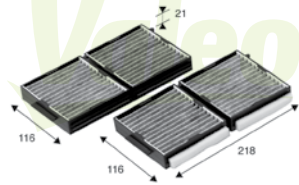
698890**CA**

MAZDA
MAZDA
MAZDA

323 (BJ)
626 (GF)
Premacy

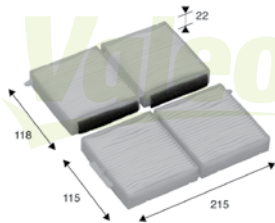
698891**PA**

MAZDA
MAZDA
MAZDA

323 (BJ)
626 (GF)
Premacy (2001>)

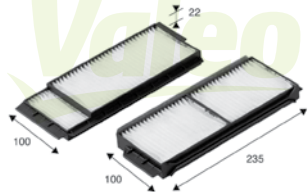
698892**PA**

MAZDA

3

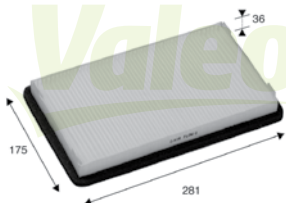
698893**PA**

FORD
MAZDA

Maverick (2000>)
Tribute

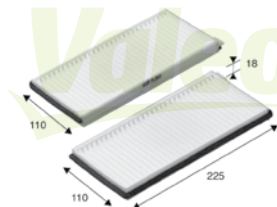
698894**PA**

SUZUKI

Grand Vitera (98->)

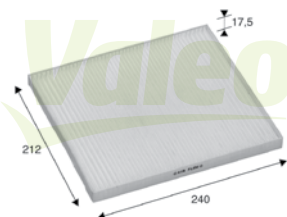
698895**PA**

KIA

Cerato

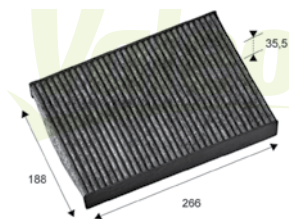
701000**PCA**

PEUGEOT

508

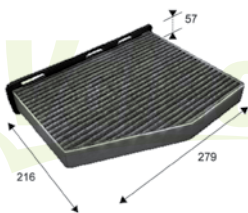
701001**PCA**

| | |
|------------|----------------------|
| AUDI | Q3 |
| SEAT | Alhambra III |
| SKODA | Superb (2008>) |
| VOLKSWAGEN | Golf VI |
| VOLKSWAGEN | New Beetle (2011>) |
| VOLKSWAGEN | Tiguan |
| VOLKSWAGEN | Touran, Touran Heros |

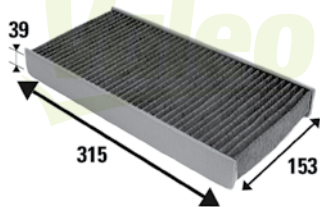
701002**PCA**

CITROËN
CITROËN
PEUGEOT

C5 (2004>2008)
C6 (2005>2008)
407, 407 Coupé

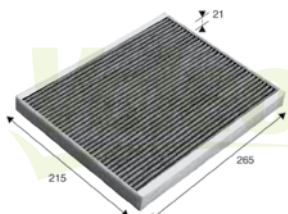
701003**PCA**

ABARTH Grande Punto, Punto Evo
 ALFA ROMEO MiTo
 FIAT Grande Punto
 FIAT Punto Evo (2009>)
 FIAT Qubo
 OPEL Corsa D (2006>)
 VAUXHALL Corsa III (2006>)

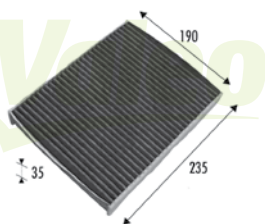
701004**PCA**

FORD Fiesta (2002>2008)
 FORD Fusion

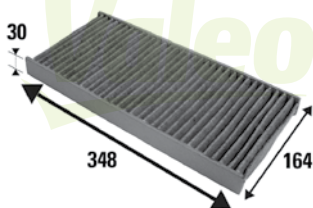
701005**PCA**

FORD Focus (98>2004)
 FORD Tourneo Connect
 FORD Transit Connect

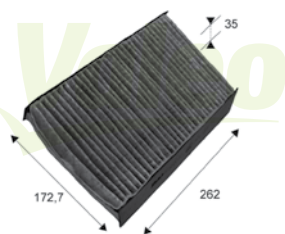
701006**PCA**

RENAULT Mégane III

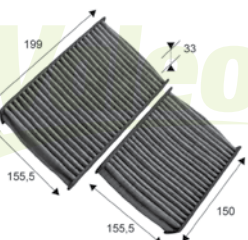
701007**PCA**

CITROËN C3 (2009>)
 CITROËN DS3
 PEUGEOT 208
 PEUGEOT 207

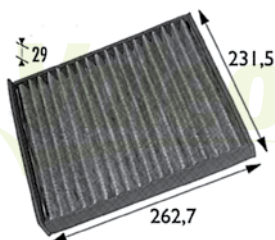
701008**PCA**

OPEL Astra G (98>2004)
 OPEL Zafira (98>2005)
 OPEL Zafira II (2005>)
 VAUXHALL Astra IV (98>2004)
 VAUXHALL Zafira

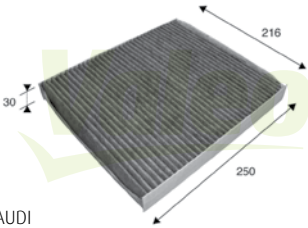
701009**PCA**

| | |
|------------|--------------------|
| AUDI | A2 |
| MERCEDES | G Class (W461/463) |
| SEAT | Cordoba (2002>) |
| SEAT | Ibiza (2001>2011) |
| SKODA | Fabia (99>2010) |
| SKODA | Roomster |
| VOLKSWAGEN | Fox |
| VOLKSWAGEN | Polo (2001>) |

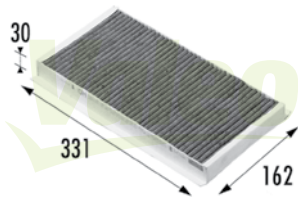
701010**PCA**

| | |
|----------|----------------------|
| CADILLAC | BLS |
| FIAT | Croma II (2005>) |
| OPEL | Corsa C (2000>2006) |
| OPEL | Vectra C (2002>) |
| SAAB | 9-3 (2002>) |
| VAUXHALL | Corsa II (2000>2006) |
| VAUXHALL | Vectra (2002>) |

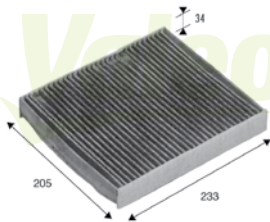
701011**PCA**

| | |
|------|----------------------|
| FORD | Focus II (2004>2011) |
| FORD | Turnier |

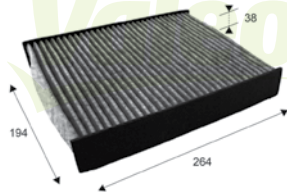
701012**PCA**

| | |
|---------|--------------|
| RENAULT | Grand Scénic |
| RENAULT | Scénic III |

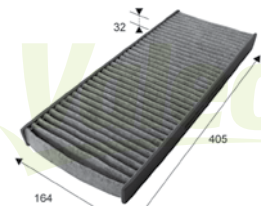
701013**PCA**

| | |
|---------|--------------------|
| CITROËN | C8 |
| CITROËN | Jumpy I (Facelift) |
| FIAT | Scudo (2004>2006) |
| FIAT | Ulysse (2002>) |
| LANCIA | Phedra |
| PEUGEOT | 807 |
| PEUGEOT | Expert (2004>2006) |

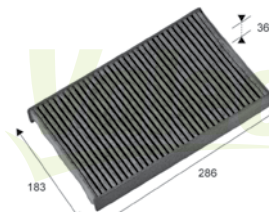
701014**PCA**

| | |
|---------|------------------------|
| CITROËN | C2, C3, C4 |
| CITROËN | C3 Picasso, C3 Pluriel |
| CITROËN | DS4 |
| PEUGEOT | 1007 |
| PEUGEOT | 307 |
| PEUGEOT | 308 |
| PEUGEOT | RCZ |

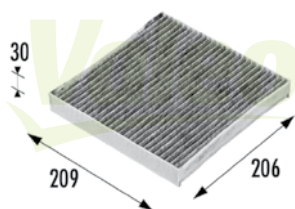
701015**PCA**

RENAULT
RENAULT

Laguna II
Vel Satis

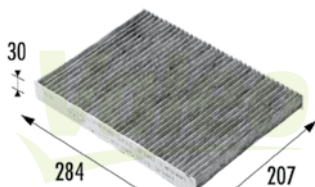
701016**PCA**

AUDI
AUDI
SEAT
SEAT
SKODA
VOLKSWAGEN
VOLKSWAGEN
VOLKSWAGEN

S3 (98>2003)
TT (98>2006)
Arosa
Leon (99>2005)
Octavia
Golf IV
New Beetle (98>)
Polo (99>2001)

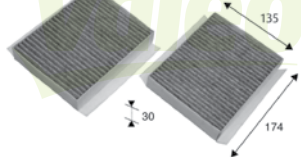
701017**PCA**

ALFA ROMEO
ALFA ROMEO
ALFA ROMEO

147 (2000>)
156 (2003>)
GT

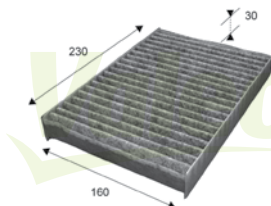
701018**PCA**

NISSAN
RENAULT
RENAULT
RENAULT
RENAULT
RENAULT

Kubistar
Clio Campus Evolution
Clio I, Clio II
Kangoo (97>2007)
Mégane (95>2002)
Thalia

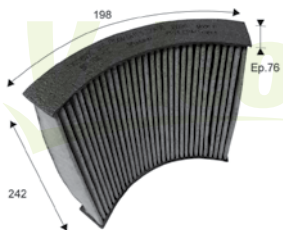
701019**PCA**

BMW
BMW

1 Serie (2012>)
3 Serie (2012)

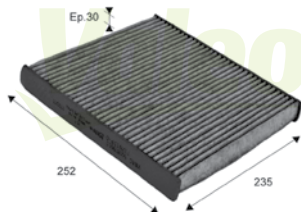
701020**PCA**

AUDI
VOLKSWAGEN

A3 (2012>)
Golf VII

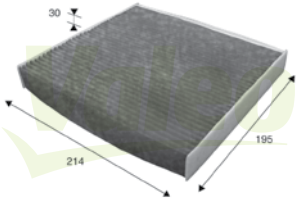
701021**PCA**

| | |
|----------|--------------------|
| DAIHATSU | Charade |
| LEXUS | CT 200h (2010>) |
| LEXUS | GS (2005>) |
| LEXUS | GX 460, IS (2005>) |
| SUBARU | Outback |
| TOYOTA | Auris |
| TOYOTA | Avensis (T27) |
| TOYOTA | Yaris (2006>) |

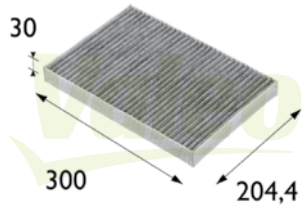
701023**PCA**

| | |
|------|-----------------|
| AUDI | A4 (2000>2007) |
| AUDI | A6 (97>2004) |
| AUDI | RS4 Quattro |
| AUDI | RS6 Quattro |
| AUDI | S4 Cabriolet II |
| AUDI | S4 V8 (2003>) |
| AUDI | S6 (99>2005) |
| SEAT | Exeo |

701024**PCA**

NISSAN

Micra (2010>)

701025**PCA**NISSAN
RENAULTJuke
Fluence**701026****PCA**

| | |
|---------|--------------------------|
| DACIA | Logan (2013>), Sandero 2 |
| RENAULT | |

701027**PCA**

| | |
|------|---|
| FORD | C-Max (CB3), Focus III, Kuga, Mondeo (2007>), S-Max |
|------|---|

701028**PCA**

NISSAN Qashqai (2007>), Rogue,
X-Trail (2007>)

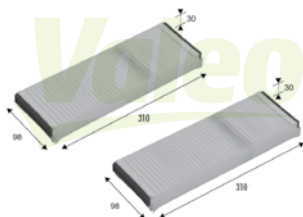
715500**PA**

AUDI

A6 (2004>)

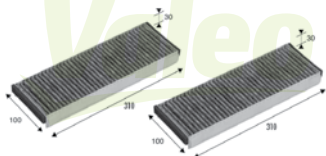
715501**CA**

AUDI A6 (2004>)
AUDI R8
LAMBORGHINI Gallardo

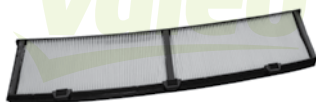
715502**PA**

BMW
BMW

1 series E87
3 series E90/E91

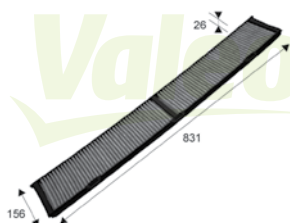
715503**CA**

BMW 1 series E87
BMW 3 series E90/E91

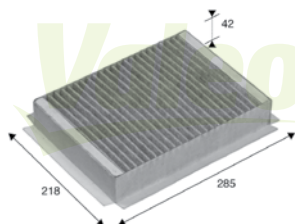
715504**CA**

JAGUAR

XJ (2002>)

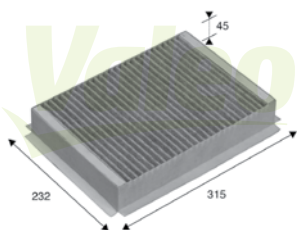
715505**CA**

JAGUAR

S-Type

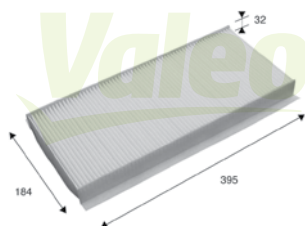
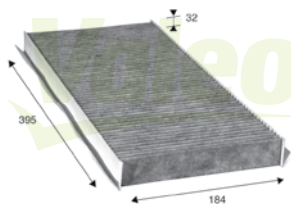
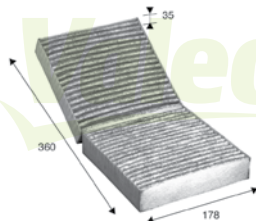
715506**PA**MERCEDES
MERCEDESA Class (169)
B Class (245)**715507****CA**MERCEDES
MERCEDESA Class (169)
B Class (245)**715508****CA**

MERCEDES

SLK (171)

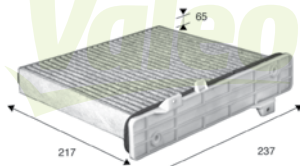
715509**CA**

MITSUBISHI

Pajero III

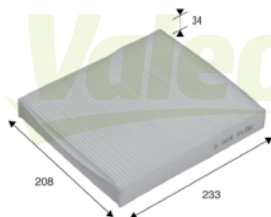
715510**PA**FORD
FORDFocus (2004>)
Turnier

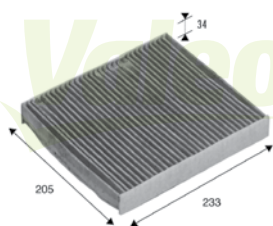
715511**CA**

FORD
FORD

Focus (2004>)
Turnier

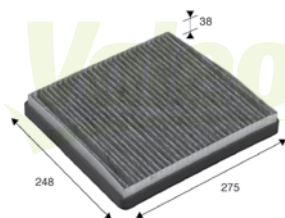
715512**CA**

VOLVO
VOLVO
VOLVO
VOLVO
VOLVO

S60
S80
V70 (2000>)
XC 70
XC 90

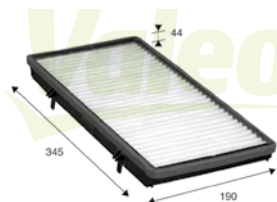
715513**PA**

NISSAN
OPEL
RENAULT
VAUXHALL

Primastar
Vivaro, Movano
Trafic (2001>)
Vivaro, Movano

715514**PA**

SAAB
SAAB

9-3
900 (93>)

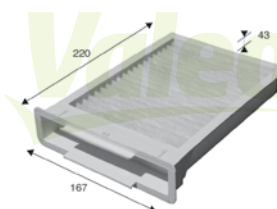
715515**PA**

CITROËN
PEUGEOT
TOYOTA

C1
107
Aygo

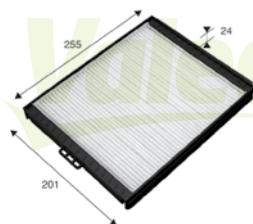
715516**PA**

HYUNDAI
HYUNDAI

Accent (1999>)
Grandeur (2005>)

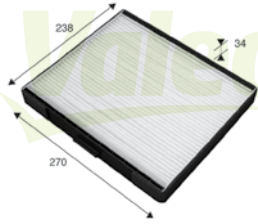
715517**PA**

HYUNDAI
HYUNDAI
HYUNDAI

Coupé (2002>)
Elantra
Matrix

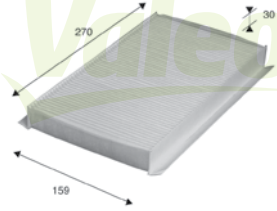
715518**PA**

LAND ROVER

Discovery III

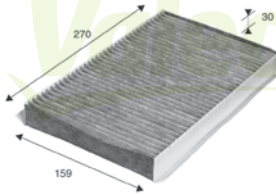
715519**CA**

LAND ROVER

Discovery III

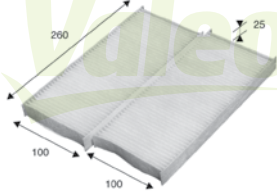
715520**PA**

NISSAN
NISSAN
NISSAN
NISSAN

Frontier
Navarra
Pathfinder (2005>)
Xterra

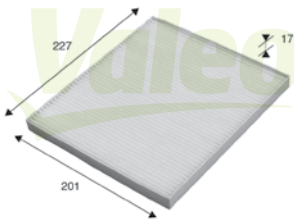
715521**PA**

HYUNDAI
HYUNDAI
KIA

i40, Tucson
Veloster
Sportage (2004>)

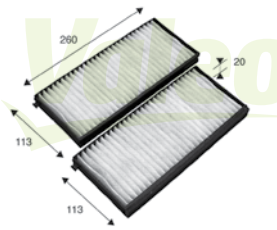
715522**PA**

KIA

Carens II

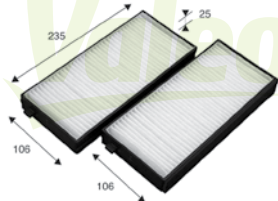
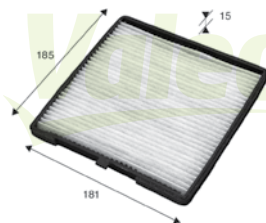
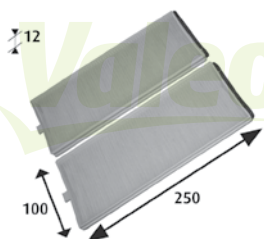
715523**PA**KIA
KIAClarus
Rio**715524****PA**HYUNDAI
KIAi10
Picanto**715525****PA**

HYUNDAI

Getz

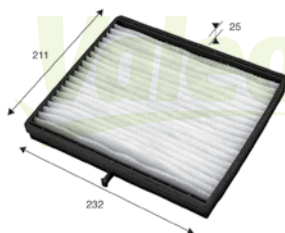
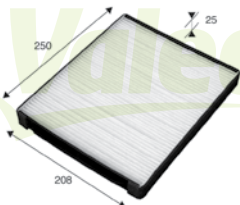
715526**PA**CHEVROLET
DAEWOOLacetti
Lacetti**715527****PA**

HYUNDAI

Terracan (HP)

715528**PA**

MITSUBISHI

Galant

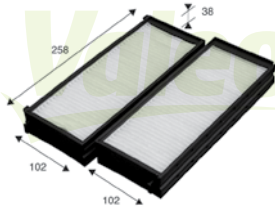
715529**PA**

HYUNDAI

Sonata (2005>)

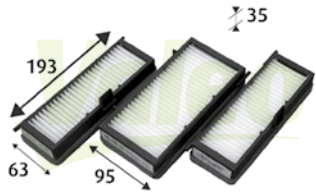
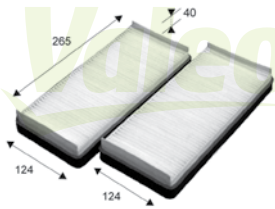
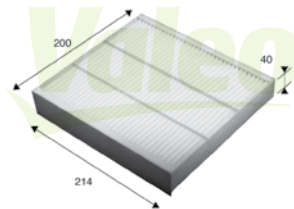
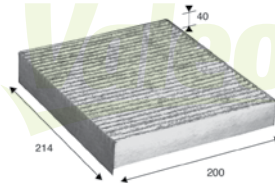
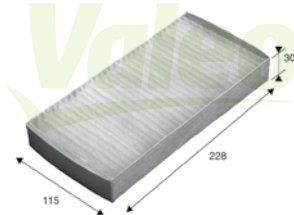
715530**PA**CITROËN
CITROËN
CITROËN
FIAT
FIAT
LANCIA
PEUGEOTEvasion
Jumpy
Synergie
Scudo
Ulysse (94>2002)
Zeta
806, Expert I (95>2004)**715531****PA**MAYBACH
MERCEDES57/62 (240)
E Class (210), S Class
(220)**715532****PA**ALFA ROMEO
ALFA ROMEO
ALFA ROMEO159
Brera
Spider**715533****CA**ALFA ROMEO
ALFA ROMEO
ALFA ROMEO159
Brera
Spider**715534****PA**

CHRYSLER

PT Cruiser

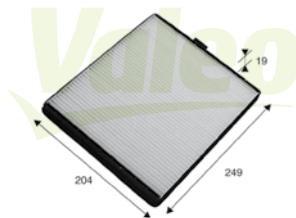
715535**PA**

CHEVROLET
CHEVROLET
DAEWOO

Aveo
Kalos
Kalos

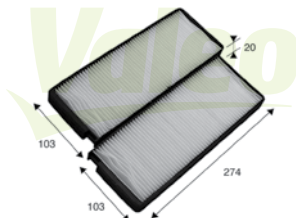
715536**PA**

CHEVROLET
CHEVROLET
DAEWOO

Rezzo
Tacuma
Rezzo, Tacuma

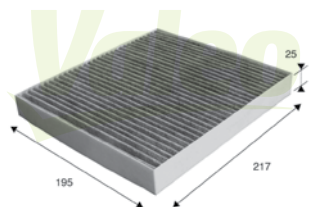
715537**CA**

DODGE
FIAT
JEEP
JEEP
LANCIA

Caliber, Journey
Freemont
Compass
Patriot
Flavia

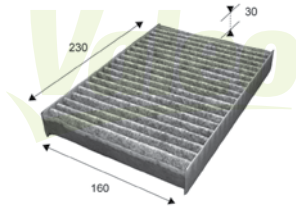
715538**CA**

NISSAN
RENAULT

RENAULT

Kubistar
Clio II, Clio Campus
Evolution (2009>),
Mégane (95>2002)
Thalia, Kangoo (97>)

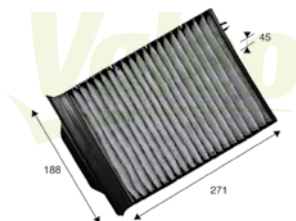
715539**CA**

RENAULT

Mégane II

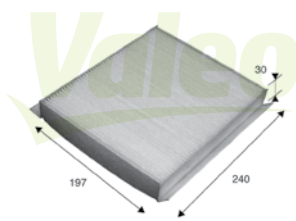
715540**PA**

HONDA

Civic (2006>)

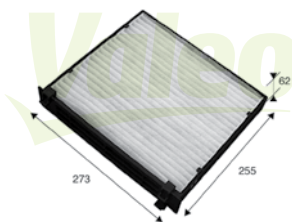
715541**PA**

HYUNDAI
KIA

Santa Fe
Magentis

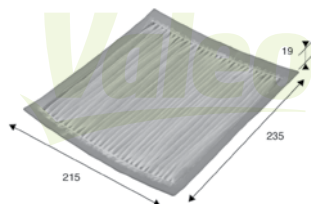
715542**PA**

LEXUS
LEXUS
LEXUS
LEXUS

GS (97>2000)
IS (99>2005)
LS (94>2000)
RX (97>2003)

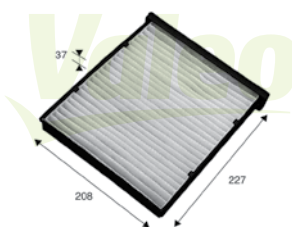
715543**PA**

MITSUBISHI
MITSUBISHI
MITSUBISHI

Colt V
L200
Lancer VI (CK1)

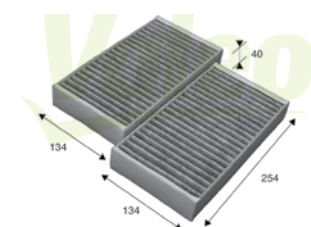
715544**CA**

MERCEDES
MERCEDES
MERCEDES

GL Class (164)
M Class (164)
R Class (251)

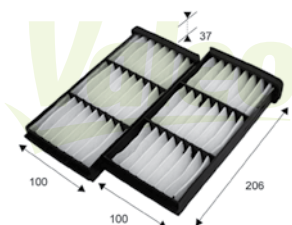
715545**PA**

MITSUBISHI

Pajero Pinin

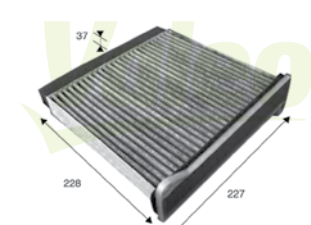
715546**PA**

MITSUBISHI
MITSUBISHI
MITSUBISHI

Grandis
Lancer VII (GS)
Outlander (2003>)

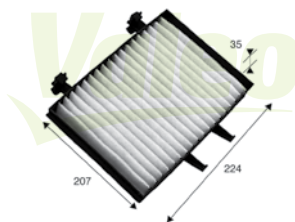
715547**PA**

MITSUBISHI
MITSUBISHI

Space Runner
Space Wagon

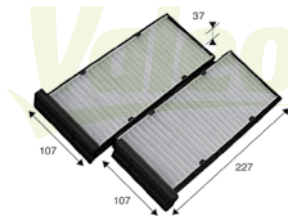
715548**PA**

MITSUBISHI
MITSUBISHI

Carisma
Space Star

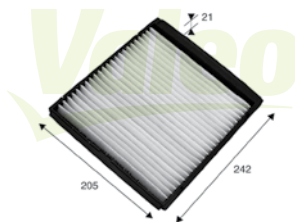
715549**PA**

NISSAN

Micra (K11)

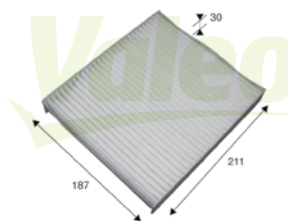
715551**PA**

SUBARU

Impreza

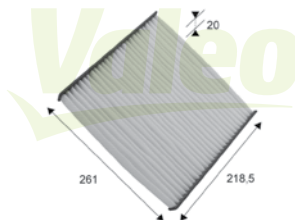
715552**PA**

ALFA ROMEO
FIAT
OPEL
VAUXHALL

MiTo
Grande Punto, Punto Evo
Corsa D (2006>)
Corsa III (2006>)

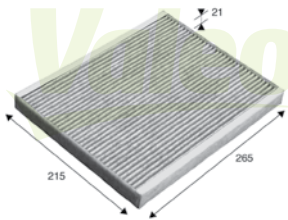
715553**CA**

FIAT
OPEL
VAUXHALL

Grande Punto
Corsa D
Corsa III (2006>)

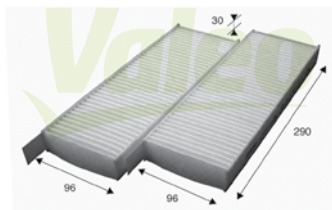
715554**PA**

CITROËN Berlingo
 CITROËN C4 Picasso, DS5
 PEUGEOT Partner
 PEUGEOT 3008, 5008

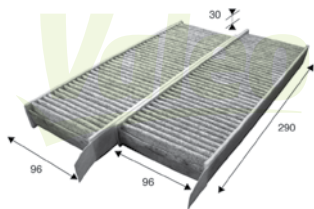
715555**CA**

CITROËN Berlingo II, C4 Picasso, C4
 Grand Picasso, DS5
 PEUGEOT 3008, 5008, Partner II

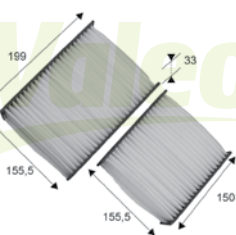
715556**PA**

CITROËN C3, DS3
 PEUGEOT 207, 208

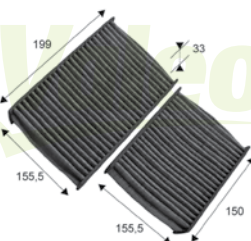
715557**CA**

CITROËN C3, DS3
 PEUGEOT 207, 208

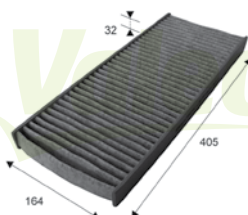
715558**CA**

CITROËN C8, Jumpy I
 FIAT Ulysse (2002>), Scudo
 (2004>2006)
 LANCIA Phedra
 PEUGEOT 807, Expert I

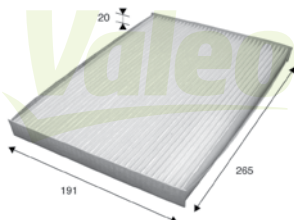
715559**PA**

NISSAN Dualis, Qashqai, Rogue, X-trail

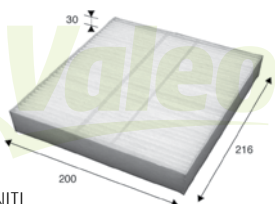
715560**CA**

INFINITI
 INFINITI G35
 NISSAN Altima
 NISSAN Maxima
 NISSAN Murano
 NISSAN X-Trail (2001>2003)
 NISSAN X-Trail (2004>)

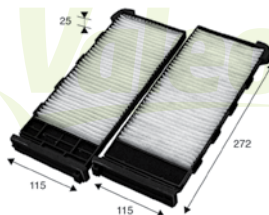
715561**PA**

INFINITI QX4
 NISSAN Pathfinder (R50) (1997>)
 NISSAN Patrol GR (Y61)

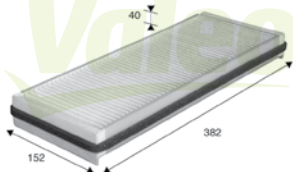
715562**PA**

RENAULT
 Espace IV (2002>)

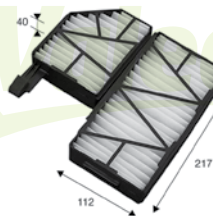
715563**PA**

SUBARU Legacy (98>2003)
 SUBARU Outback (2000>2003)

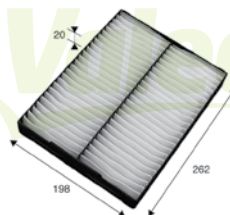
715564**PA**

SUZUKI
 Grand Vitara (2005>)

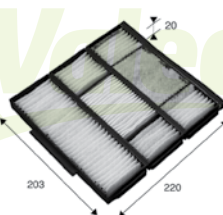
715565**PA**

TOYOTA Corolla (110) (97>99)
 TOYOTA Corolla (110) (99>2001)

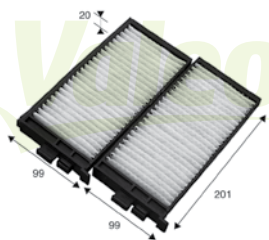
715566**PA**

SSANGYONG
SSANGYONG
SSANGYONG

Korando
Musso
Musso Sport

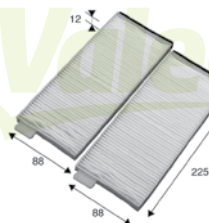
715567**PA**

SSANGYONG
SSANGYONG
SSANGYONG

Korando
Musso
Musso Sport

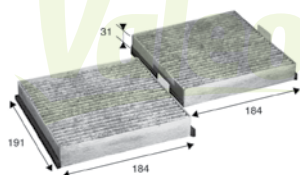
715568**CA**

RENAULT
RENAULT

Avantime
Espace III (96>2002)

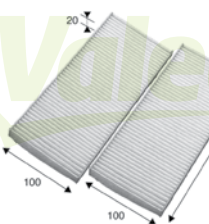
715569**PA**

ISUZU
OPEL
VAUXHALL

Trooper (2000>)
Monterey
Monterey

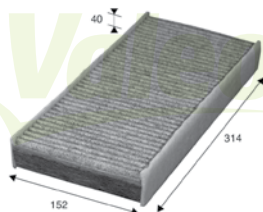
715570**PA**

CITROËN
CITROËN
PEUGEOT

C5 (2004>)
C6
407, Coupé

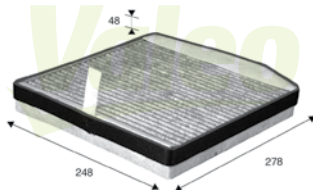
715571**CA**

VOLVO
VOLVO
VOLVO
VOLVO
VOLVO

S60
S80
V70 (2000>)
XC 70
XC 90 (2002>)

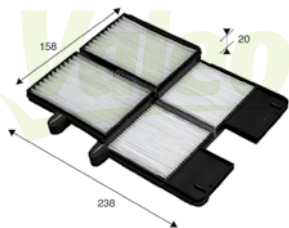
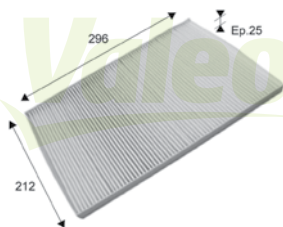
715572**PA**TOYOTA
TOYOTAAvensis (T22)
Carina E (T19)**715573****PA**

HONDA

Accord (98>2003)

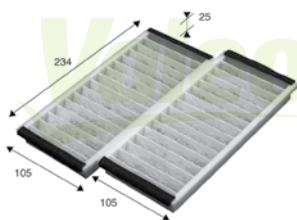
715574**PA**MAZDA
MAZDAMPV
RX-8**715575****PA**

NISSAN

Almera (95>2000)

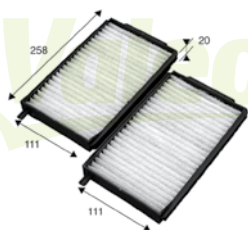
715576**PA**

MAZDA

Demio

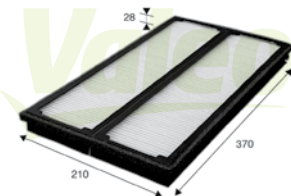
715577**PA**MERCEDES
MERCEDESV Class (638)
Vito (638)

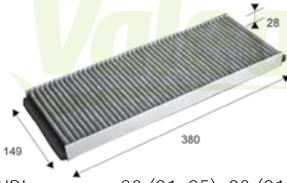
715578**CA**

AUDI 80 (91>95), 90 (91>95)
 AUDI A4 (94>2000), S4 (97>99)
 AUDI Cabriolet
 AUDI Coupé (88>96)
 AUDI RS4 Quattro
 VOLKSWAGEN Passat (96>2000)

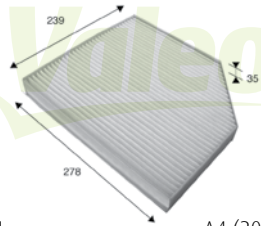
715579**PA**

AUDI A4 (2007>)
 AUDI A5
 AUDI Q5
 AUDI S4 (2008>)
 AUDI S5

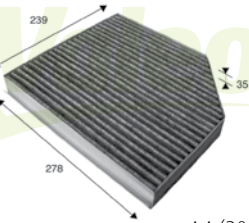
715580**CA**

AUDI A4 (2007>)
 AUDI A5
 AUDI Q5
 AUDI S4 (2008>)
 AUDI S5

715581**PA**

AUDI Q7
 VOLKSWAGEN Touareg
 VOLKSWAGEN Caravelle
 VOLKSWAGEN Transporter (7J)/7H (2003>)

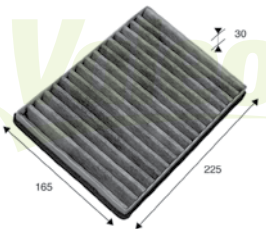
715582**CA**

BMW 7 series E65/E66

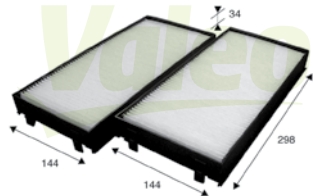
715583**PA**

BMW X5 E70

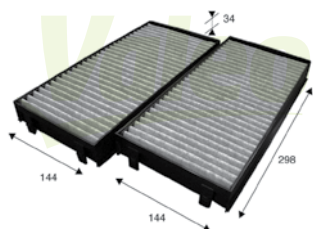
715584**CA**

BMW

X5 E70

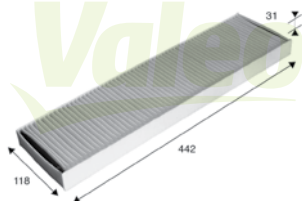
715585**PA**

MINI

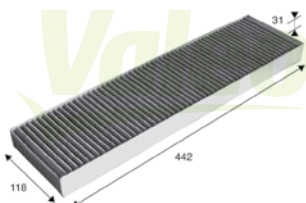
Mini (2006>), Mini 2
LCI(R56/R57), Club-
man(R55)**715586****CA**

MINI

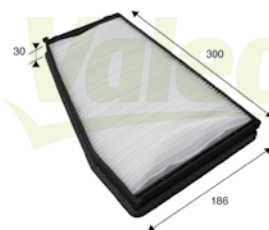
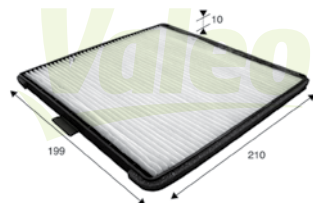
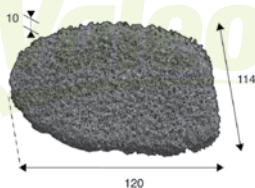
Mini (2006>), Mini 2
LCI(R56/R57), Club-
man(R55)**715587****PA**CHEVROLET
CHEVROLET
CHEVROLETEpica
Evanda
Magnus**715588****PA**CHEVROLET
DAEWOOMatiz
Matiz**715589****PA**CITROËN
PEUGEOTSaxo (96>99)
106

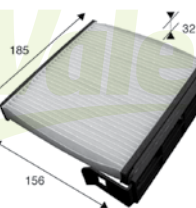
715590**PA**

DAIHATSU

CUORE VII

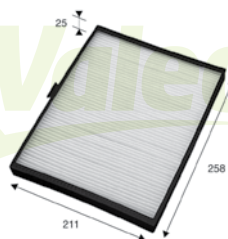
715591**PA**

HYUNDAI

Elantra (2000>)

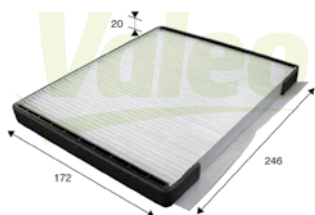
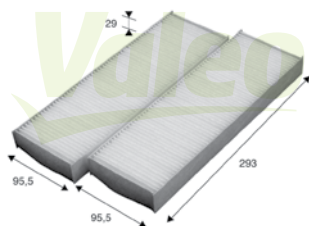
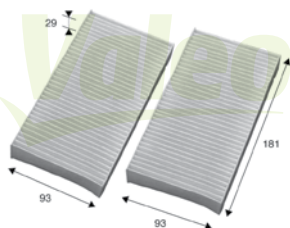
715592**PA**HYUNDAI
HYUNDAIAccent (2005>)
i30 cw**715593****PA**HONDA
HONDAAccord VII Coupe (97>)
Acura CL**715594****PA**

HONDA

HR-V

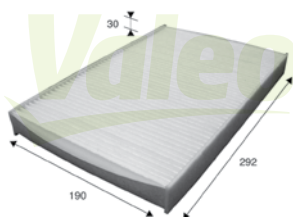
715595**PA**

IVECO

Daily (2006>)

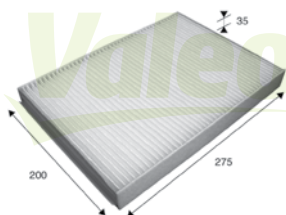
715597**PA**

LAND ROVER
VOLVO

Freelander
S60 II, S80, V60, V70
(2007>), XC 60, XC 70
(2007>)

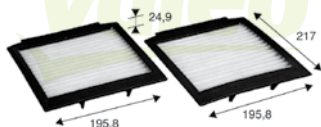
715598**PA**

LAND ROVER Range Rover (94>2002)

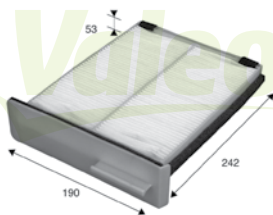
715599**PA**

MAZDA 323 (BJ) (98>2000)
MAZDA 323 (BJ) (2000>2003)
MAZDA 626 (GF) (99>2002)
MAZDA Premacy (99>2001)

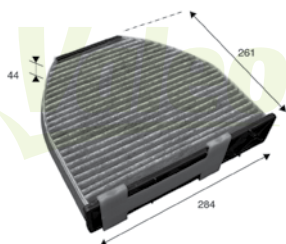
715600**CA**

MERCEDES C Class (204)

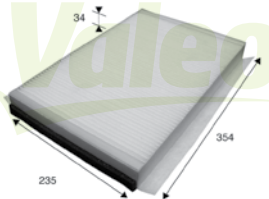
715601**PA**

MERCEDES
VOLKSWAGEN

Sprinter II
Crafter

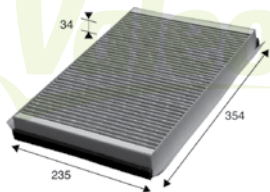
715602**CA**

MERCEDES
VOLKSWAGEN

Sprinter II
Crafter

715603

PA

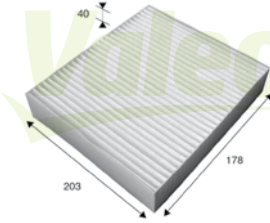

MITSUBISHI

Colt VI (2004>)

715607

CA

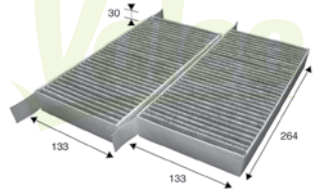

RENAULT

Laguna III (2007>)

715608

CA

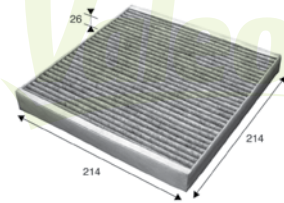

SMART

Fortwo

715609

PA

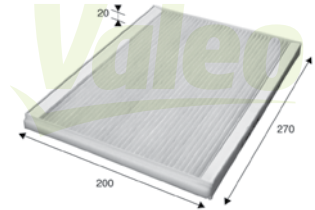

SUZUKI

Grand Vitara III

715610

CA

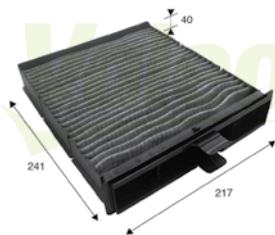

RENAULT

Scénic II

715611

CA

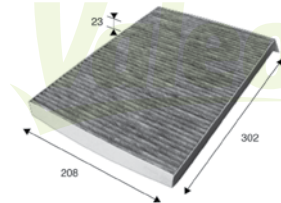

CHRYSLER

Grand Voyager (2004>)

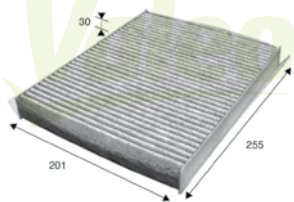
715612**CA**

CITROËN

Xsara Picasso

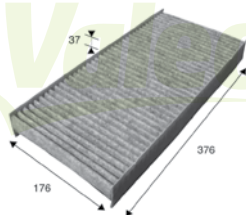
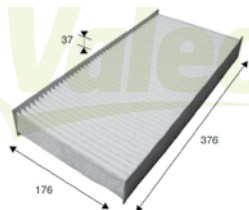
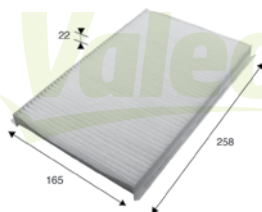
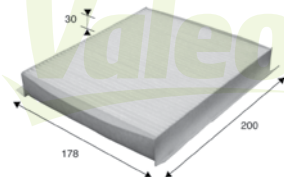
715613**PA**CITROËN
FIAT
PEUGEOTJumpy II
Scudo II
Expert II**715614****CA**CITROËN
FIAT
PEUGEOTJumpy II
Scudo II
Expert II**715615****PA**FIAT
FIAT
FIAT
FIATAlbea
Palio
Siena
Strada Pick Up**715616****PA**

FIAT

Linea, Fiorino

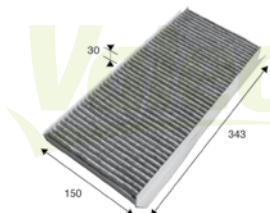
715617**CA**FORD
FORD
FORD
FORD
MAZDAFiesta (95>2002)
Ka
Puma
Courier
121 (JA/JB) (96>)

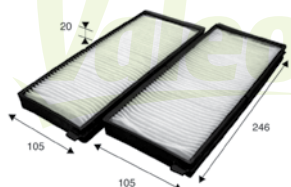
715618**PA**

KIA

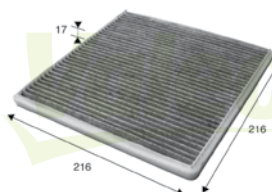
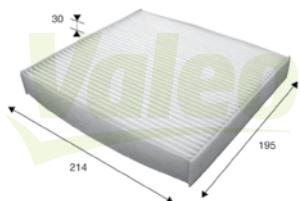
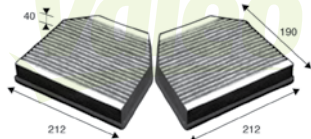
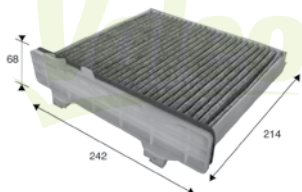
Sportage (94>2004),
Shuma II, Spectra (USA)**715619****CA**LEXUS
SUBARURX 300, RX 350, RX 400
Legacy (2003>), Outback
(2003>), TribecaTOYOTA 4 Runner, Avalon, Avensis Verso (2001>)
TOYOTA Land Cruiser (2002>), Yaris, Yaris Verso**715620****PA**LEXUS
LEXUS
TOYOTA
TOYOTA
TOYOTA
TOYOTAGS (2005>)
IS (2005>)
Auris, Avalon, Avensis (T27)
RAV4 II, Land Cruiser Prado
Urban Cruiser, Yaris II (2006>)
Verso-S**715621****CA**MERCEDES
MERCEDESSL (R230)
SLR (R199)**715622****CA**

MITSUBISHI

Pajero III (2000>)

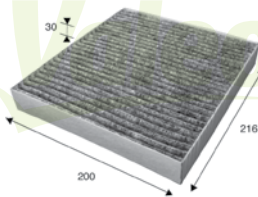
715623**CA**CITROËN
MITSUBISHI
PEUGEOTC Crosser
Lancer VIII / IV,
Outlander (2007>)
4008

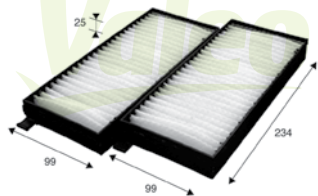
715624**PA**

SSANGYONG

Kyrön

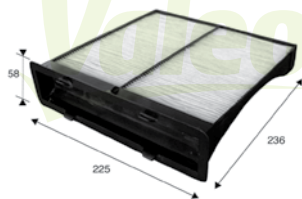
715625**PA**

SUBARU

Impreza III

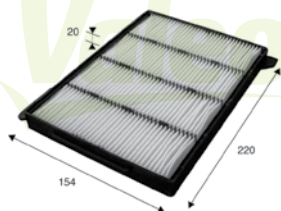
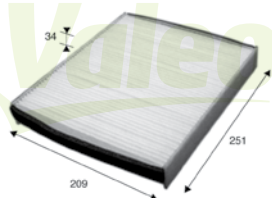
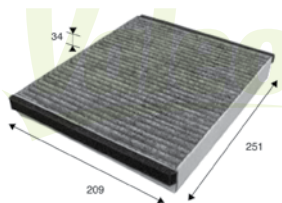
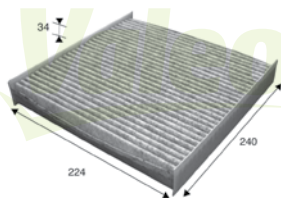
715626**PA**SUBARU
SUBARUForester I
Impreza I**715627****PA**VOLVO
VOLVO
VOLVO
VOLVOC30
C70 (2006>)
S40 (2004>)
V50**715628****CA**VOLVO
VOLVO
VOLVO
VOLVOC30
C70 (2006>)
S40 (2004>)
V50**715629****CA**CITROËN
CITROËNXsara (97>2000)
Berlingo (2002>)

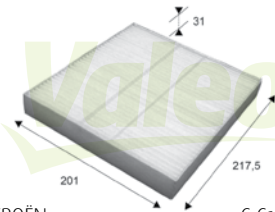
715631**PA**

CITROËN C Crossover
 PEUGEOT 4007, 4008
 INFINITI FX, G35
 MITSUBISHI Airtrek II, Lancer VIII
 MITSUBISHI Outlander (2007>)
 NISSAN Altima, Maxima VI, Murano
 NISSAN X-Trail (2001>2003)

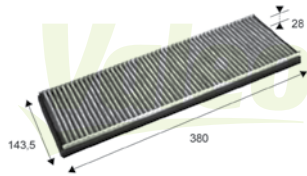
715632**CA**

OPEL Astra F (91>98), Calibra
 OPEL Corsa B (93>2000), Tigra
 (94>2003)
 OPEL Combo (93>2001)
 VAUXHALL Astra III (91>98), Calibra
 VAUXHALL Corsa I (93>2000), Tigra
 VAUXHALL Combo (93>2001)

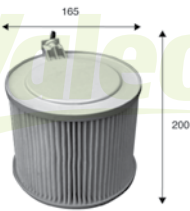
715633**PA**

RENAULT

Kangoo (97>2003)

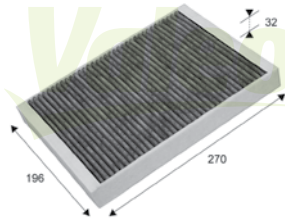
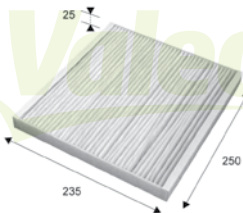
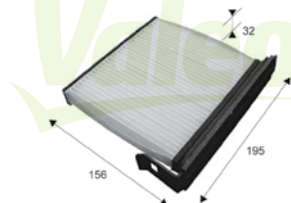
715635**CA**CITROËN
PEUGEOTC5 (2008>), C6
407**715636****PA**CITROËN
PEUGEOT
FIATJumper (2006>)
Ducato (2006>)
Boxer (2006>)**715637****PA**

DAIHATSU

Sirion II

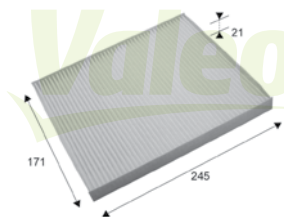
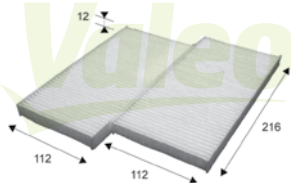
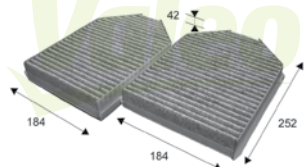
715638**PA**HYUNDAI
KIAi 30
Cee'd**715639****PA**HYUNDAI
KIATucson
Sorento (JC)**715640****CA**

JAGUAR

Xk

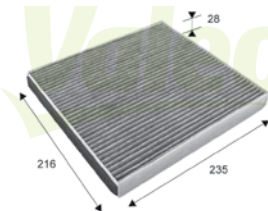
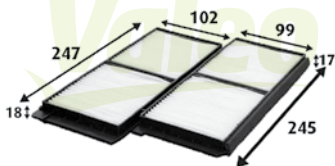
715641**CA**LEXUS
LEXUS
LEXUSGS (2000>2005)
LS (2000>2006)
SC 430**715642****PA**

MAZDA

2 (2007>)

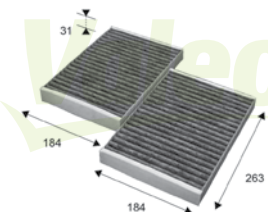
715643**CA**

MERCEDES

S Class (221)

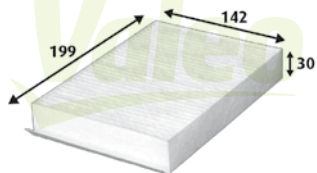
715644**PA**

OPEL
SUZUKI
VAUXHALL

Agila
Splash
Agila

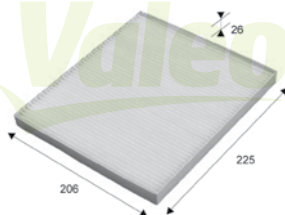
715645**PA**

VAUXHALL
VAUXHALL

Corsa I (93>2000)
Tigra

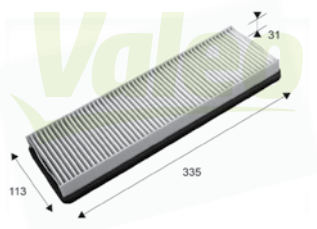
715646**PA**

PEUGEOT

306

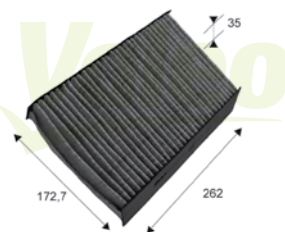
715647**CA**

RENAULT

Mégane III

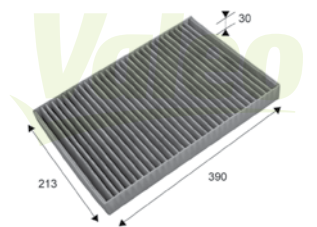
715648**CA**

CHRYSLER
DODGE

300 C
Magnum

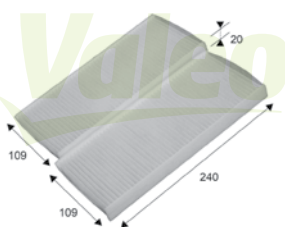
715649**PA**

NISSAN
RENAULT

NV400
Kangoo (2008->)

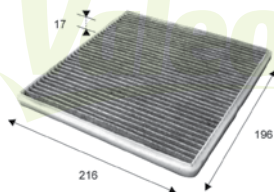
715650**CA**

Scion
 TOYOTA
 TOYOTA
 TOYOTA

xA, Xb
 Echo
 RAV4 (2000>2006)
 Yaris (NCP/SCP)

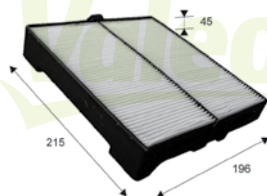
715651**PA**

SUBARU

Forester II

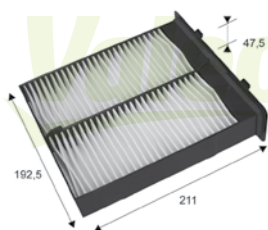
715652**PA**

SUZUKI

SX4

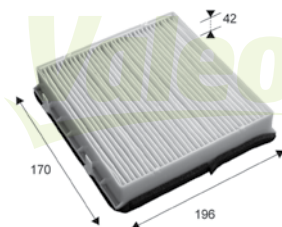
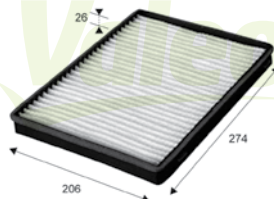
715653**PA**SEAT
VOLKSWAGENToledo (91>1998)
Golf I, Jetta II**715654****PA**

CHEVROLET
 OPEL
 SATURN
 VAUXHALL

Captiva
 Antara
 Vue
 Antara

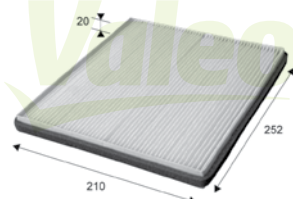
715655**PA**

LDV

Maxus

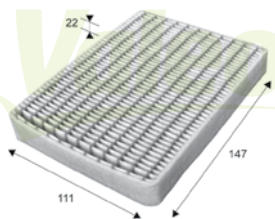
715656**PA**

HYUNDAI

Getz (A/C-)

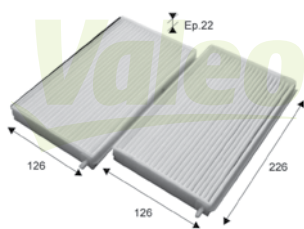
715657**PA**

MAZDA

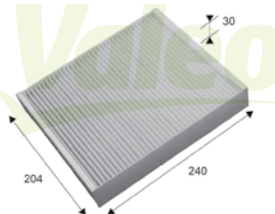
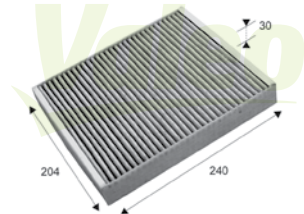
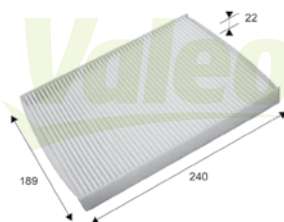
Xedos 9 (TA)/
Xedos 6 (CA)**715658****PA**CHEVROLET
OPEL
VAUXHALLOrlando, Malibu
Insignia
Insignia**715659****CA**CHEVROLET
OPEL
VAUXHALLOrlando, Malibu
Insignia
Insignia**715660****PA**

FORD

Fiesta

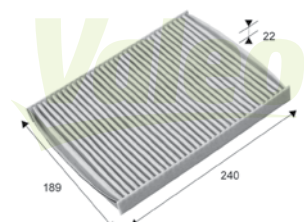
715661**CA**

FORD

Fiesta

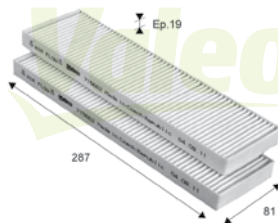
715662**PA**

HYUNDAI

i20

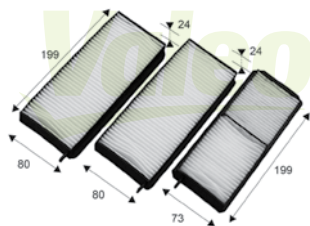
715664**PA**

MAZDA

323 (BA)

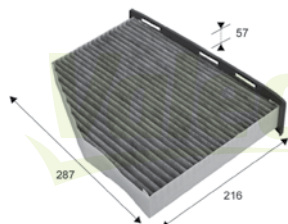
715665**CA**

AUDI A3 II, TT coupe, Roadster
 SEAT Alhambra III (2010>), Toledo III
 SKODA Octavia II
 VOLKSWAGEN Eos, Golf Plus, Golf V
 VOLKSWAGEN Jetta, Passat, Tiguan, Touran

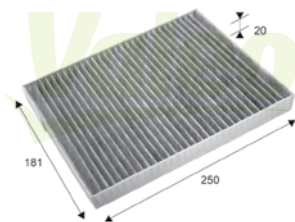
715667**CA**

RENAULT

Koleos

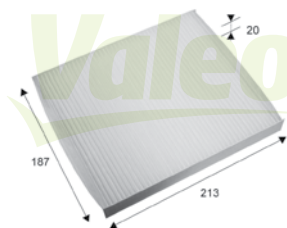
715668**PA**

SUZUKI

Jimny

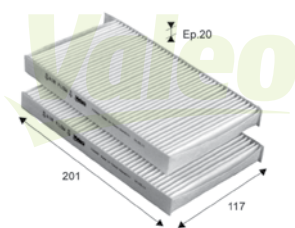
715669**PA**HYUNDAI
HYUNDAIH1 Starex
i800, iLoad

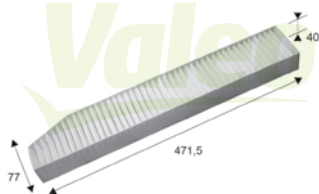
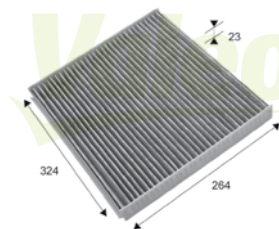
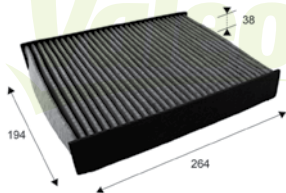
715670**PA**JEEP
JEEPCherokee II, III
Grand Cherokee II, III**715671****CA**CADILLAC
CADILLACCTS
SRX**715672****CA**

RENAULT

Scénic III, Grand Scénic

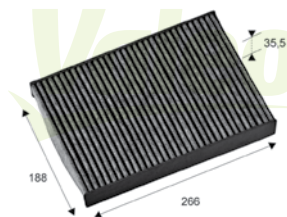
715673**CA**

PEUGEOT

508

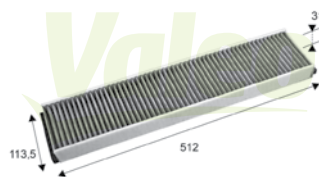
715674**CA**

FORD

Mondeo (93>2000)

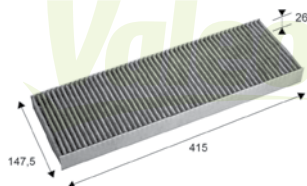
715675**CA**OPEL
VAUXHALLVectra B (95>2002)
Vectra (95>2002)

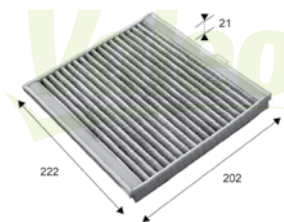
715676**CA**

VOLVO

S40 (95>2004), V40

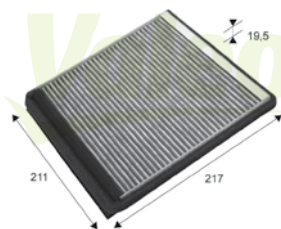
715677**CA**

CITROËN

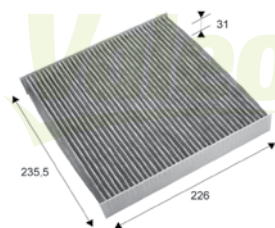
Xsara (N1) (97>2000),
Berlingo (2002>)**715678****CA**

HONDA

Accord VIII (2003>), Civic
(2006>)

HONDA

CR-V (2006>), Legend

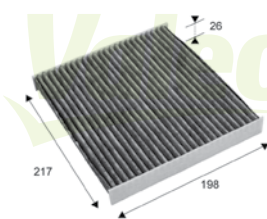
715679**CA**

MAZDA

6 (2002>)

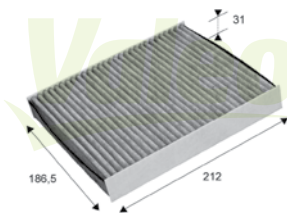
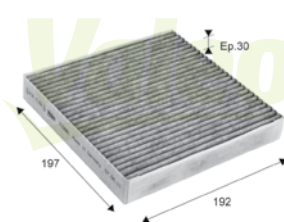
715680**CA**SAAB
SUBARU9 -2x
Impreza (GD, GG)**715681****CA**

JAGUAR

XF

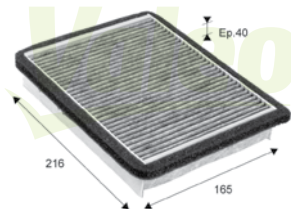
715682**CA**

LADA

110, 111, 112

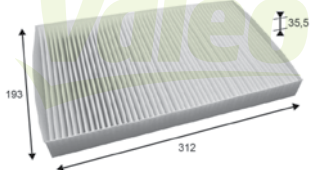
715683**PA**

AUDI

A6 (94>97), A6 (97>2001)

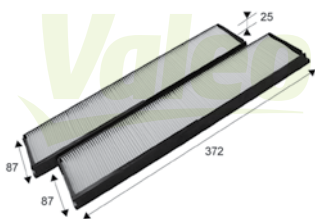
715684**PA**

MERCEDES

E Class (124)

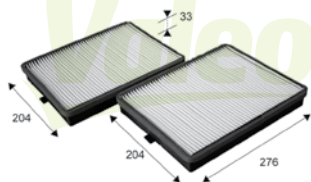
715685**PA**

BMW

5 series E39, M5 E39

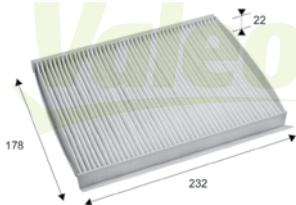
715686**PA**

FIAT

Bravo II, Stilo (2001>2007)

715687**PA**

VOLVO

S60, S80, V70 (2000>),

VOLVO

XC 70 (97>99), XC 70

(2000>2007)

VOLVO

XC 90 (2002>)

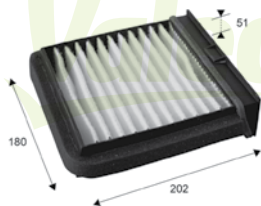
715688**PA**

MITSUBISHI Carisma, Space Star

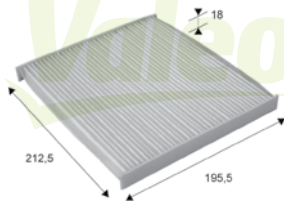
715689**PA**

TOYOTA Corolla Verso (E12) 2.0 D4D

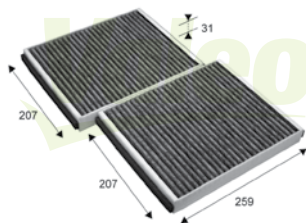
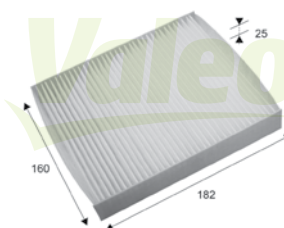
715690**CA**BMW 5 series (F07GT), 5 series (F10)
BMW 7 series (F01/F02)**715691****PA**

KIA Soul

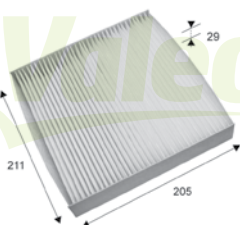
715692**PA**

HONDA CR-Z, City, Insight, Jazz

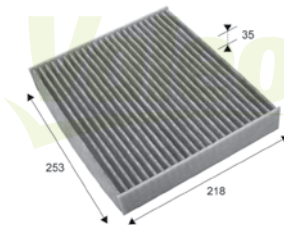
715693**CA**

PORSCHE Panamera

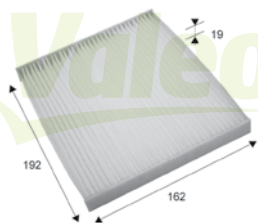
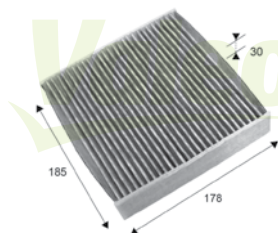
715694**PA**NISSAN
SUZUKIPixo
Alto**715695****CA**

DAIHATSU

Cuore VII, Terios

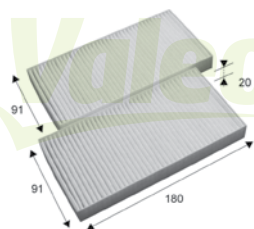
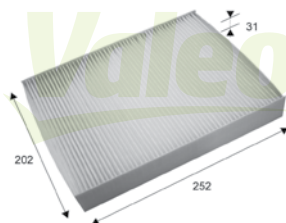
715696**PA**DODGE
JEEPNitro,
Liberty II**715697****PA**

HYUNDAI

ix35, Veracruz

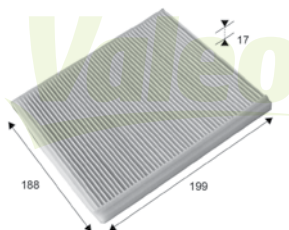
715698**PA**

SUZUKI

Liana

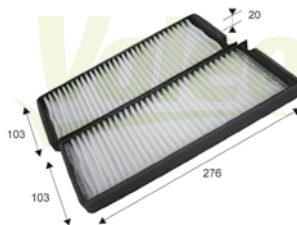
715699**PA**

SSANGYONG

Rexton

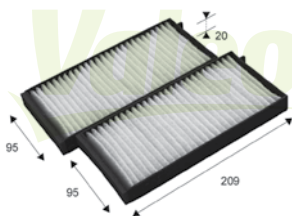
715700**PA**

SSANGYONG

Rodius

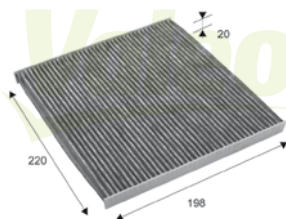
715701**CA**

TOYOTA Corolla IX, Verso IX, Avensis

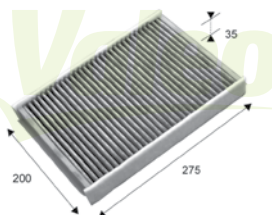
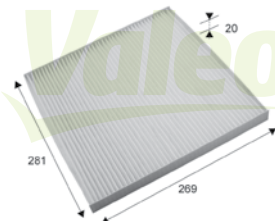
715702**CA**VOLVO
LAND ROVERXC60, S80 II
Freelander II**715703****PA**

NISSAN

Murano, Teana

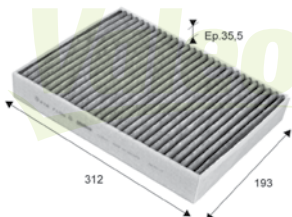
715704**CA**

VOLKSWAGEN

Touareg

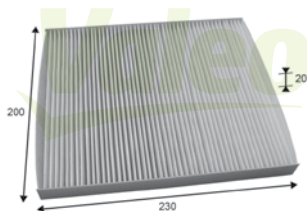
715705**PA**

ALFA ROMEO

Giulietta (2010>)

715706

PA

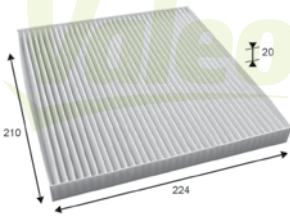

NISSAN

Micra IV

715707

PA

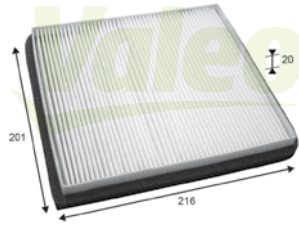

CHEVROLET

Spark

715708

PA

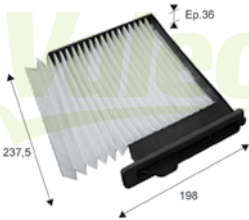

NISSAN

NV200, Tiida

715709

PA

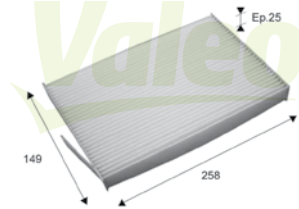

NISSAN

Cube, Leaf

715710

CA

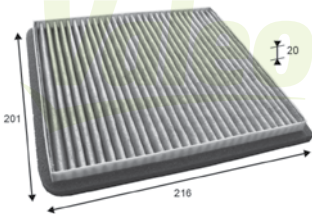

CHEVROLET

Spark

715711

PA

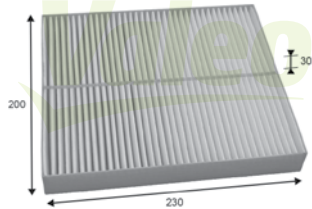

CHRYSLER

Grand Voyager (2008->)

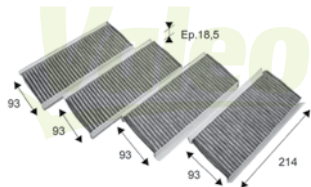
715712**CA**

BMW

3 series (E90-E94)

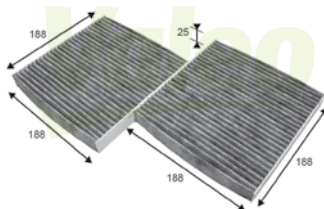
715713**CA**

BMW

X3 (F25) x Drive

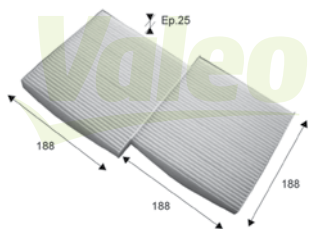
715714**PA**

BMW

X3 (F25)

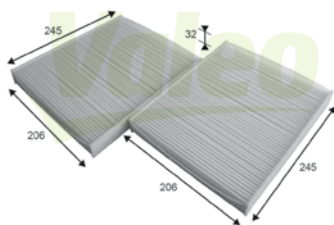
715715**PA**

BMW

5 series (F10, F11, F18)

BMW

6 series (F12, F13)

BMW

7 series (F01, F02)

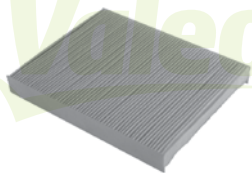
715716**PA**

HYUNDAI

Santa Fe II

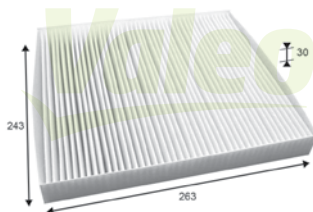
715717**PA**

JEEP

Grand Cherokee IV

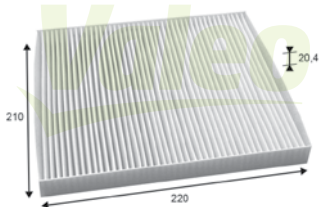
715718**PA**

ISUZU

D-Max

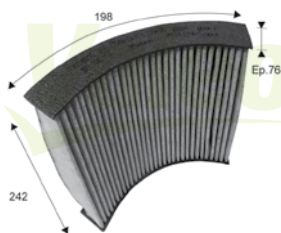
715719**PA**

BMW

Serie 1 & 3 (2012)

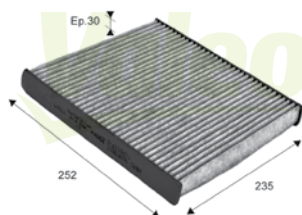
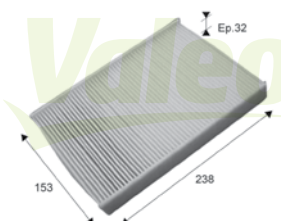
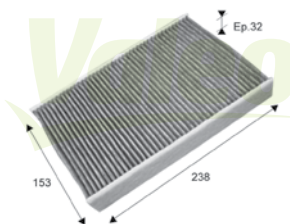
715720**PA**AUDI
VOLKSWAGENA3
Golf VII**715721****PA**NISSAN
RENAULTJuke
Fluence**715722****CA**

RENAULT

Fluence

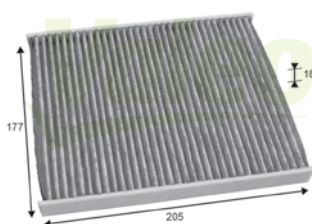
715723**CA**FIAT
FORDPanda,500
Ka II

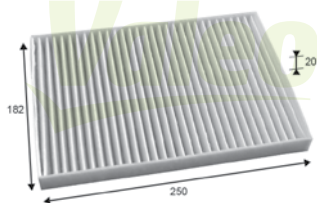
715724**PA**

RENAULT

Koleos

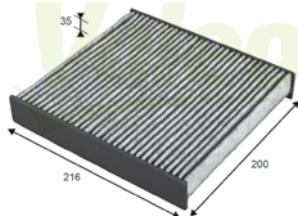
715725**CA**

RENAULT

Clio IV

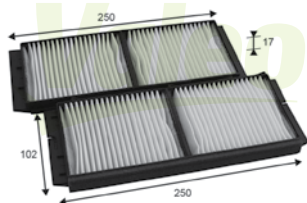
715726**PA**

MAZDA

3 (2008>)

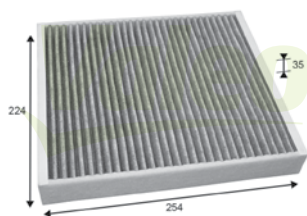
715727**CA**AUDI
SEAT
SKODAA1 (2010>)
Ibiza
Fabia (2010>), Praktik,
Roomster
Polo

VOLKSWAGEN

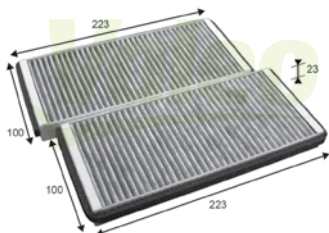
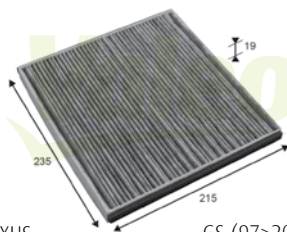
715728**CA**MAZDA
MAZDAMPV
RX-8**715729****CA**LEXUS
LEXUS
LEXUS
LEXUS
TOYOTA
TOYOTAGS (97>2000)
IS (99>2005)
LS (94>2000)
RX (97>2003)
Harrier
Highlander I

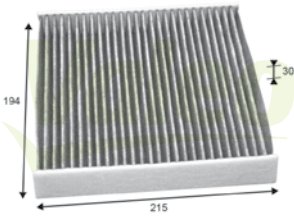
715730**CA**

LEXUS CT 200h (2010>)
 LEXUS GS (2005>)
 LEXUS IS (2005>)
 SUBARU Legacy
 TOYOTA Auris
 TOYOTA Avensis (T27)
 TOYOTA Yaris (2006>)

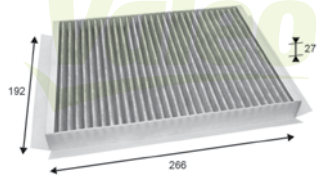
715731**CA**

CHEVROLET

Captiva (2011>)

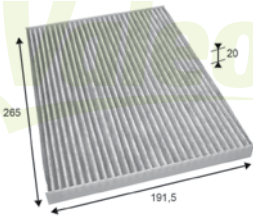
715732**CA**

NISSAN

Qashqai (2007>2010)

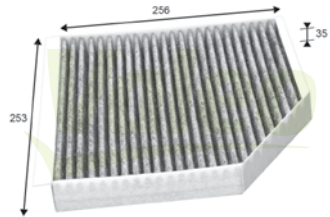
715733**CA**

AUDI A6 (2010>)
 AUDI A6 Allroad (2012>)
 AUDI A7 (2010>)
 AUDI A8 (2009>)
 AUDI S7
 AUDI S8 (2012>)
 BENTLEY Mulsanne

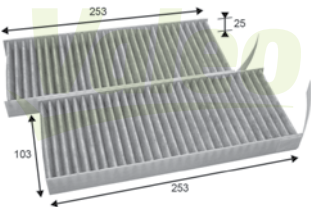
715734**CA**

RENAULT

Latitude

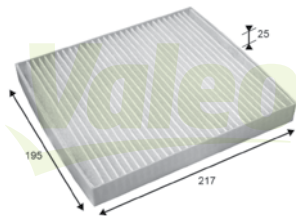
715735**PA**

CHRYSLER Sebring (2006>)
 DODGE Avenger
 DODGE Journey
 FIAT Freemont
 JEEP Compass
 LANCIA Flavia

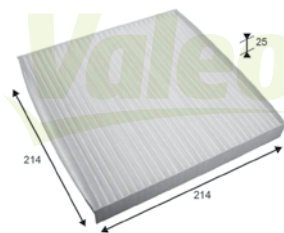
715736**PA**

SMART

Fortwo

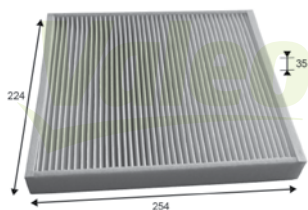
715737**CA**AUDI
SEAT
SKODAA1 (2010>)
Ibiza
Fabia (2010>), Praktik,
Roomster
Polo

VOLKSWAGEN

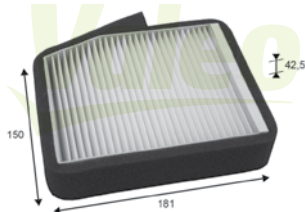
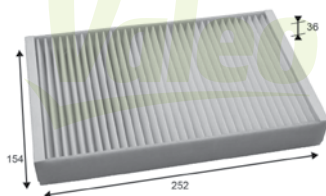
715738**PA**HYUNDAI H1 (2000>2006)
HYUNDAI H1 Mini Bus (2001>2006)**715739****PA**

LADA

Kalina 1118, 1119

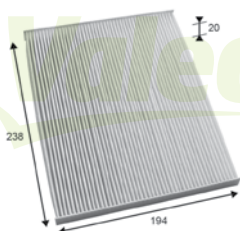
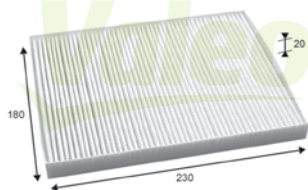
715740**PA**HYUNDAI ix35
HYUNDAI Tucson
KIA Sportage III**715741****PA**HYUNDAI ix20
KIA Venga (2010>)

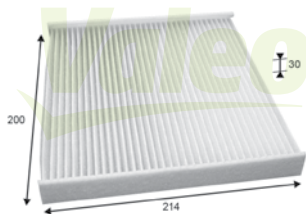
715742**PA**

FORD

Transit (2006>)

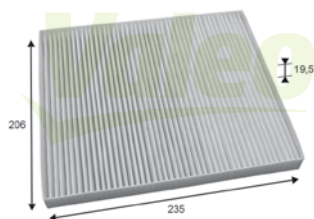
715743**PA**

SUZUKI

Kizashi Sport

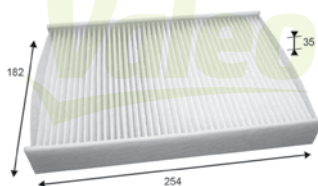
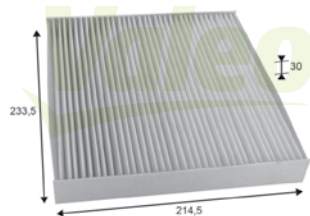
715744**PA**SEAT
SKODA
VOLKSWAGENMii
Citigo
UP**715745****PA**FORD
MAZDARanger
BT-50 II**715746****PA**DACIA Logan (2013>), Sandero 2
RENAULT Captur, Clio IV**715747****CA**

FORD

Transit (2006>)

715748

PA



HYUNDAI

i20, 140

715749

PA



LANCIA

Thema II

715750

CA



MAZDA

Demio

715751

PA



MERCEDES

GL Class (166), ML (166)

715752

CA



OPEL
VAUXHALL

Meriva B
Meriva B

715753

CA



PORSCHE

911, Boxster Lyberta

715754

PA



PORSCHE

911, Boxster Lyberta

715755

PA



CHRYSLER

FIAT

LANCIA

Ypsilon (2011>)
500, Panda 312 (Nuova)
Ypsilon 2011

715756

CA



NISSAN

Micra (2010>)

715757

CA



FORD

VOLVO

C-Max (B7), Focus III,
Gallopier
V40 II



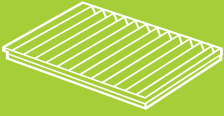
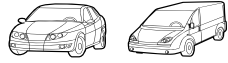

Valeo



Valeo









Valeo





|  |  |  |  |
|---|---|---|---|
| 698146 | PA | 6447Z4 | CITROËN Berlingo |
| 698146 | PA | 6447Z4 | CITROËN Xantia |
| 698146 | PA | 6447Z4 | CITROËN Xsara |
| 698146 | PA | 6447Z5 | PEUGEOT Partner |
| 698146 | PA | 6447Z5 | PEUGEOT Ranch |
| 698149 | PA | 7700845811 | RENAULT Mégane (95>99) |
| 698159 | PA | 1H0819644B | AUDI A3 (96>2003) |
| 698159 | PA | 1H0819644B | SEAT Arosa |
| 698159 | PA | 1H0819644B | SEAT Cordoba (93>2002) |
| 698159 | PA | 1H0819644B | SEAT Ibiza (93>2001) |
| 698159 | PA | 1H0819644B | SEAT Inca |
| 698159 | PA | 1H0819644B | SEAT Leon |
| 698159 | PA | 1H0819644B | SEAT Toledo (98>) |
| 698159 | PA | 1H0819644B | SKODA Octavia (96>2004) |
| 698159 | PA | 1H0819644B | SKODA Superb |
| 698159 | PA | 1H0819644B | VOLKSWAGEN Caddy (95>2004) |
| 698159 | PA | 1H0819644B | VOLKSWAGEN Golf II Cabriolet |
| 698159 | PA | 1H0819644B | VOLKSWAGEN Golf III (91>97) |
| 698159 | PA | 1H0819644B | VOLKSWAGEN Golf III Cabriolet |
| 698159 | PA | 1H0819644B | VOLKSWAGEN Lupo |
| 698159 | PA | 1H0819644B | VOLKSWAGEN New Beetle (2001>2005) |
| 698159 | PA | 1H0819644B | VOLKSWAGEN Polo (94>2001) |
| 698159 | PA | 1H0819644B | VOLKSWAGEN Vento |
| 698160 | PA | 1H0819638 | VOLKSWAGEN Golf III (91>97) |
| 698160 | PA | 1H0819638 | VOLKSWAGEN Vento |
| 698163 | PA | 3A0819644 | VOLKSWAGEN Passat (93>97) |
| 698164 | PA | 8A0819439A | AUDI 80 (91>95) |
| 698164 | PA | 8A0819439A | AUDI A4 (94>2000) |
| 698164 | PA | 8A0819439A | AUDI Cabriolet |
| 698164 | PA | 8A0819439A | AUDI Coupé (88>96) |
| 698164 | PA | 8A0819439A | AUDI RS4 Quattro (2000>2001) |
| 698164 | PA | 8A0819439A | AUDI S4 (97>99) |
| 698164 | PA | 8A0819439A | VOLKSWAGEN Passat (96>2000) |
| 698165 | PA | 1808602 | OPEL Astra F |
| 698165 | PA | 1808602 | OPEL Astra G |
| 698165 | PA | 1808602 | OPEL Calibra |
| 698165 | PA | 1808602 | OPEL Corsa B |
| 698165 | PA | 1808602 | OPEL Tigra |
| 698165 | PA | 90486282 | VAUXHALL Astra III |
| 698165 | PA | 90486282 | VAUXHALL Calibra |
| 698166 | PA | 1808604 | OPEL Combo |
| 698166 | PA | 1808604 | OPEL Corsa B |
| 698166 | PA | 1808604 | OPEL Tigra |
| 698166 | PA | 90386776 | VAUXHALL Combo |

|  |  |  |  |
|---|---|---|---|
| 698166 | PA | 90386776 | VAUXHALL Corsa I |
| 698166 | PA | 90386776 | VAUXHALL Tigra |
| 698167 | PA | 1808605 | OPEL Omega A (86>1994) |
| 698167 | PA | 1808605 | OPEL Omega B |
| 698167 | PA | 90510338 | VAUXHALL Omega |
| 698168 | PA | 1097670 | FORD Cougar |
| 698168 | PA | 1097670 | FORD Mondeo |
| 698169 | PA | 5101438AA | CHRYSLER Crossfire |
| 698169 | PA | 2028300018 | MERCEDES C Class (202), CLK (208) |
| 698169 | PA | 2028300018 | MERCEDES E Class (210) |
| 698169 | PA | 2028300018 | MERCEDES S Class (220) |
| 698169 | PA | 2028300018 | MERCEDES SLK (170) |
| 698170 | PA | 64311390836 | BMW 5 series E34 |
| 698170 | PA | 64311390836 | BMW 7 series E32 |
| 698170 | PA | 64311390836 | BMW M5 E34 |
| 698171 | PA | 64119069895 | BMW 3 series E36 |
| 698171 | PA | 5101438AA | BMW M3 E36 |
| 698173 | PA | 7700834816 | RENAULT Laguna (94>98) |
| 698173 | PA | 7700834816 | RENAULT Laguna (98>2000) |
| 698174 | PA | 46409630 | ALFA ROMEO GTV (95>2003) |
| 698174 | PA | 46721923 | ALFA ROMEO 145 |
| 698174 | PA | 46721923 | ALFA ROMEO 146 |
| 698174 | PA | 46721923 | ALFA ROMEO 155 |
| 698174 | PA | 71712595 | ALFA ROMEO Spider (2003>) |
| 698174 | PA | 71712595 | ALFA ROMEO Spider (95>2003) |
| 698174 | PA | 71712595 | FIAT Coupe |
| 698174 | PA | 71712595 | FIAT Tempra |
| 698174 | PA | 71712595 | FIAT Tipo |
| 698174 | PA | 71712595 | LANCIA Dedra |
| 698174 | PA | 71712595 | LANCIA Delta (93>99) |
| 698175 | PA | 7700846236 | RENAULT Mégane Scénic |
| 698176 | PA | 7700845219 | RENAULT Mégane Scénic |
| 698177 | PA | 7700845222 | RENAULT Mégane Scénic |
| 698196 | PA | 79831ST3E01 | HONDA Accord VII (98>2003) |
| 698196 | PA | 79831ST3E01 | HONDA Civic V (EJ*) (96>2000) |
| 698196 | PA | 79831ST3E01 | HONDA Civic V (MA/MB) (95>2001) |
| 698196 | PA | JKR100020 | MG MG ZR |
| 698196 | PA | JKR100020 | MG MG ZS |
| 698196 | PA | JKR100020 | ROVER 200 |
| 698196 | PA | JKR100020 | ROVER 25 |
| 698196 | PA | JKR100020 | ROVER 400 (95>) |
| 698196 | PA | JKR100020 | ROVER 45 |
| 698196 | PA | JKR100020 | ROVER Streetwise |
| 698197 | PA | 60653641 | ALFA ROMEO 156 (97>2003) |





|  |  |  |  |
|---|---|---|---|
| 698197 | PA | 46442422 | FIAT Brava |
| 698197 | PA | 46442422 | FIAT Bravo |
| 698197 | PA | 46442422 | FIAT Marea |
| 698197 | PA | 46442422 | FIAT Marengo (185) (95>) |
| 698197 | PA | 46442422 | LANCIA Dedra |
| 698197 | PA | 60653641 | LANCIA Lybra |
| 698198 | PA | 46721374 | FIAT Punto (93>99) |
| 698198 | PA | 46721374 | LANCIA Y Ipsilon (95>2000) |
| 698199 | PA | 7797229 | ALFA ROMEO 164 (92>98) |
| 698199 | PA | 82472557 | FIAT Croma |
| 698199 | PA | 82398550 | LANCIA Thema |
| 698199 | PA | 9625674 | SAAB 9000 |
| 698201 | PA | 1004051 | FORD Courier (96>) |
| 698201 | PA | 1004051 | FORD Fiesta (95>2002) |
| 698201 | PA | 1004051 | FORD Ka, StreetKa |
| 698201 | PA | 1004051 | FORD Puma |
| 698201 | PA | 1E0061J6X | MAZDA 121 (JA/JB) (96>) |
| 698202 | PA | 1808607 | OPEL Vectra B |
| 698202 | PA | 90512779 | VAUXHALL Vectra (95>2002) |
| 698203 | PA | 6447S5 | PEUGEOT 406 |
| 698203 | PA | 99657121901 | PORSCHE 911 (996), Boxster (986) |
| 698235 | PA | 644793 | PEUGEOT 405 (92>96) |
| 698246 | CA | 64319069927 | BMW 5 series E39 |
| 698246 | CA | 64319069927 | BMW M5 E39 |
| 698247 | PA | 7420372 | FORD Galaxy |
| 698247 | PA | 7H0819638A | SEAT Alhambra |
| 698247 | PA | 7M0819644 | VOLKSWAGEN Sharan |
| 698255 | PA | B729800QAA | NISSAN Kubistar |
| 698255 | PA | 7700424098 | RENAULT Clio II, Clio Campus Evolution (2009>) |
| 698255 | PA | 7700424098 | RENAULT Kangoo |
| 698255 | PA | 7700424098 | RENAULT Mégane |
| 698255 | PA | 7700424098 | RENAULT Thalia |
| 698276 | PA | 7700424093 | RENAULT Mégane |
| 698279 | PA | 7700428820 | RENAULT Mégane Scénic |
| 698290 | PA | 6025370624 | RENAULT Avantime |
| 698290 | PA | 6025370624 | RENAULT Espace III |
| 698454 | PA | 46794399 | FIAT Multipla |
| 698469 | PA | 64319071933 | BMW 3 series E36 Compact |
| 698470 | CA | 64319070072 | BMW 7 series E38 |
| 698475 | PA | 1688300018 | MERCEDES A Class (168) |
| 698475 | PA | 1688300018 | MERCEDES Vaneo (414) |
| 698487 | PA | 1062253 | FORD Focus |
| 698487 | PA | 1062253 | FORD Tourneo Connect |
| 698487 | PA | 1062253 | FORD Transit Connect |



|  |  |  |  |
|---|---|---|---|
| 698488 | PA | 6447AZ | PEUGEOT 206, 206 CC, 206+ |
| 698489 | PA | 64311000004 | BMW 3 series E46 |
| 698489 | PA | 64311000004 | BMW X3 |
| 698512 | PA | 7701047513 | RENAULT Mégane Scénic |
| 698535 | PA | 46770834 | FIAT Doblo |
| 698535 | PA | 46770834 | FIAT Punto II |
| 698540 | PA | 6447HT | CITROËN C5 (2001>2004) |
| 698541 | CA | 6447HV | CITROËN C5 (2001>2004) |
| 698594 | PA | 7701048748 | RENAULT Laguna II |
| 698594 | PA | 7701048748 | RENAULT Vel Satis |
| 698606 | PA | 8E0819439 | AUDI A4 (2000>) |
| 698606 | PA | 8E0819439 | AUDI A6 (97>2001) |
| 698606 | PA | 8E0819439 | SEAT Exeo |
| 698657 | PA | 6447HP | CITROËN Berlingo |
| 698657 | PA | 6447HP | CITROËN Xsara (2000>) |
| 698657 | PA | 6447KR | PEUGEOT Partner |
| 698657 | PA | 6447KR | PEUGEOT Ranch |
| 698662 | PA | 1808610 | OPEL Astra G |
| 698662 | PA | 90520689 | VAUXHALL Astra IV |
| 698663 | PA | 1808612 | OPEL Astra G |
| 698663 | PA | 1808612 | OPEL Zafira |
| 698663 | PA | 90559549 | VAUXHALL Zafira |
| 698664 | PA | 6447NT | CITROËN C2, C3 |
| 698664 | PA | 6447NT | CITROËN C3 Pluriel |
| 698664 | PA | 6447NT | CITROËN C3 Picasso (2009>) |
| 698664 | PA | 6447NT | CITROËN C4, C4 II, DS4 |
| 698664 | PA | 6447KK | PEUGEOT 1007 |
| 698664 | PA | 6447KK | PEUGEOT 307, 308 |
| 698679 | PA | 1H0819644A | VOLKSWAGEN Passat (2000>) |
| 698680 | PA | 6447FF | CITROËN Xsara Picasso |
| 698681 | PA | 8856852010 | TOYOTA Echo |
| 698681 | PA | 8856852010 | TOYOTA RAV4 (2000>) |
| 698681 | PA | 8856852010 | TOYOTA Yaris JPP |
| 698681 | PA | 8856852010 | TOYOTA Yaris Verso |
| 698681 | PA | 8856852010 | SCION Xa |
| 698681 | PA | 8856852010 | SCION xB |
| 698682 | CA | 4B0819439A | AUDI A6 (97>2001) |
| 698683 | CA | 4B0819439C | AUDI A4 (2000>) |
| 698683 | CA | 4B0819439C | AUDI A6 (97>2004) |
| 698683 | CA | 4B0819439C | AUDI A6 Allroad (2000>) |
| 698683 | CA | 4B0819439C | AUDI S6 (99>) |
| 698683 | CA | 4B0819439C | SEAT Exeo |
| 698684 | CA | 4A0819439A | AUDI 100 (90>94) |
| 698684 | CA | 4A0819439A | AUDI A6 (94>97) |





|  |  |  |  |
|---|---|---|---|
| 698684 | CA | 4A0819439A | AUDI S4 (99>2001) |
| 698685 | PA | 6Q0820367 | AUDI A2 |
| 698685 | PA | 6Q0820367 | SEAT Cordoba (2002>) |
| 698685 | PA | 6Q0820367 | SEAT Ibiza (2001>) |
| 698685 | PA | 6Q0820367 | SKODA Fabia, Roomster |
| 698685 | PA | 6Q0820367 | VOLKSWAGEN Fox |
| 698685 | PA | 6Q0820367 | VOLKSWAGEN Polo (2001>) |
| 698686 | CA | 1H0091800 | AUDI A3 (96>2003) |
| 698686 | CA | 1H0091800 | SEAT Arosa |
| 698686 | CA | 1H0091800 | SEAT Cordoba (93>2002) |
| 698686 | CA | 1H0091800 | SEAT Ibiza (93>2001) |
| 698686 | CA | 1H0091800 | SEAT Toledo (98>) |
| 698686 | CA | 1H0091800 | SKODA Octavia (96>2004) |
| 698686 | CA | 1H0091800 | VOLKSWAGEN Caddy (95>2004) |
| 698686 | CA | 1H0091800 | VOLKSWAGEN Golf III (91>97) |
| 698686 | CA | 1H0091800 | VOLKSWAGEN Golf III Cabriolet |
| 698686 | CA | 1H0091800 | VOLKSWAGEN Passat (2000>) |
| 698686 | CA | 1H0091800 | VOLKSWAGEN Polo (94>99) |
| 698686 | CA | 1H0091800 | VOLKSWAGEN Vento |
| 698687 | CA | 60815647 | ALFA ROMEO 156 |
| 698687 | CA | 46768502 | FIAT Brava/o, Marea |
| 698687 | CA | 60815647 | LANCIA Dedra, Lybra |
| 698688 | CA | 60814643 | ALFA ROMEO 166 |
| 698688 | CA | 60814643 | LANCIA Kappa |
| 698688 | CA | 382400304 | MASERATI 3200GT |
| 698688 | CA | 382400304 | MASERATI Coupe, Spider |
| 698689 | PA | 60653642 | ALFA ROMEO 156 (97>2003) |
| 698689 | PA | 46412715 | FIAT Brava |
| 698689 | PA | 46412715 | FIAT Bravo |
| 698689 | PA | 46412715 | FIAT Marea |
| 698689 | PA | 46412715 | FIAT Marengo (185) (95>) |
| 698690 | PA | 7079682 | FIAT Palio |
| 698690 | PA | 7079682 | FIAT Siena |
| 698690 | PA | 7079682 | FIAT Strada Pick Up |
| 698691 | PA | 7078711 | FIAT Palio |
| 698691 | PA | 7078711 | FIAT Siena |
| 698692 | CA | 46723435 | FIAT Stilo |
| 698693 | CA | 1204464 | FORD Fiesta (2002>) |
| 698693 | CA | 1204464 | FORD Fusion |
| 698693 | CA | DD1061P11 | MAZDA 2 |
| 698694 | PA | 1204459 | FORD Fiesta (2002>) |
| 698694 | PA | 1204459 | FORD Fusion |
| 698695 | CA | 1121106 | FORD Focus |
| 698695 | CA | 1121106 | FORD Tourneo Connect |

|  |  |  |  |
|---|---|---|---|
| 698695 | CA | 1121106 | FORD Transit Connect |
| 698696 | CA | 1113627 | FORD Galaxy |
| 698696 | CA | 7M3819644 | SEAT Alhambra |
| 698696 | CA | 7M3819644A | VOLKSWAGEN Sharan |
| 698697 | CA | 5101439AA | CHRYSLER Crossfire |
| 698697 | CA | 2108300818 | MERCEDES C Class (202) |
| 698697 | CA | 2108300818 | MERCEDES CLK (208) |
| 698697 | CA | 2108300818 | MERCEDES E Class (210) |
| 698697 | CA | 2108300818 | MERCEDES SLK (170) |
| 698700 | PA | 2038300118 | MERCEDES C Class (203) |
| 698700 | PA | 2038300118 | MERCEDES CLK (209) |
| 698701 | PA | 2038300218 | MERCEDES C Class (203) |
| 698701 | PA | 2038300218 | MERCEDES CLK (209) |
| 698702 | PA | 2118300218 | MERCEDES CLS (219) |
| 698702 | PA | 2118300218 | MERCEDES E Class (211) |
| 698704 | PA | 1408350047 | MERCEDES S Class (140) |
| 698705 | CA | 1408350447 | MERCEDES S Class (140) |
| 698706 | PA | 1408350547 | MERCEDES S Class (140) |
| 698707 | PA | 5029916 | FORD Maverick (93>98) |
| 698707 | PA | 278932F900 | NISSAN Primera (P11) (96>2001) |
| 698707 | PA | 278932F900 | NISSAN Terrano II (R20) (93>2001) |
| 698708 | CA | 1718042 | OPEL Astra G |
| 698708 | CA | 1718042 | OPEL Zafira |
| 698708 | CA | 91132364 | VAUXHALL Astra IV |
| 698708 | CA | 91132364 | VAUXHALL Zafira |
| 698710 | CA | 1808624 | CADILLAC Bls |
| 698710 | CA | 46844822 | FIAT Croma II (2005>) |
| 698710 | CA | 1808624 | OPEL Combo (2001>) |
| 698710 | CA | 1808624 | OPEL Corsa C |
| 698710 | CA | 1808624 | OPEL Signum |
| 698710 | CA | 1808624 | OPEL Tigra Twintop |
| 698710 | CA | 1808624 | OPEL Vectra C |
| 698710 | CA | 9179905 | SAAB 9-3 (2002>) |
| 698710 | CA | 93172129 | VAUXHALL Corsa II |
| 698710 | CA | 93172129 | VAUXHALL Tigra Twintop |
| 698710 | CA | 93172129 | VAUXHALL Signum |
| 698710 | CA | 93172129 | VAUXHALL Vectra (2002>) |
| 698711 | PA | 6808601 | CADILLAC BLS |
| 698711 | PA | 1808619 | OPEL Combo (2001>) |
| 698711 | PA | 1808619 | OPEL Corsa C |
| 698711 | PA | 1808619 | OPEL Signum |
| 698711 | PA | 1808619 | OPEL Tigra Twintop |
| 698711 | PA | 1808619 | OPEL Vectra C (2002>) |
| 698711 | PA | 9179904 | SAAB 9-3 (2002>) |





|  |  |  |  |
|---|---|---|---|
| 698711 | PA | 93172299 | VAUXHALL Corsa II |
| 698711 | PA | 93172299 | VAUXHALL Signum |
| 698711 | PA | 93172299 | VAUXHALL Tigra Twintop |
| 698711 | PA | 93172299 | VAUXHALL Vectra (2002->) |
| 698712 | PA | 1808609 | OPEL Sintra |
| 698712 | PA | 52470574 | VAUXHALL Sintra |
| 698713 | CA | 6447GW | PEUGEOT 607 |
| 698714 | CA | 6447NV | CITROËN C2 |
| 698714 | CA | 6447NV | CITROËN C3 |
| 698714 | CA | 6447NV | CITROËN C3 Picasso (2009->) |
| 698714 | CA | 6447NV | CITROËN C3 Pluriel |
| 698714 | CA | 6447NV | CITROËN C4, C4 II, DS4 |
| 698714 | CA | 6447KL | PEUGEOT 1007, Rcz |
| 698714 | CA | 6447KL | PEUGEOT 307, 308 |
| 698715 | CA | 7701048749 | RENAULT Laguna II |
| 698715 | CA | 7701048749 | RENAULT Vel Satis |
| 698716 | CA | 1J0819644A | AUDI A3 (96>2003) |
| 698716 | CA | 1J0819644A | AUDI S3 |
| 698716 | CA | 1J0819644A | AUDI TT |
| 698716 | CA | 1J0819644A | SEAT Arosa |
| 698716 | CA | 1J0819644A | SEAT Leon |
| 698716 | CA | 1J0819644A | SKODA Octavia (2000>2004) |
| 698716 | CA | 1J0819644A | VOLKSWAGEN Bora |
| 698716 | CA | 1J0819644A | VOLKSWAGEN Golf III (91>97) |
| 698716 | CA | 1J0819644A | VOLKSWAGEN Golf III Cabriolet |
| 698716 | CA | 1J0819644A | VOLKSWAGEN Golf IV (97>2003) |
| 698716 | CA | 1J0819644A | VOLKSWAGEN Lupo |
| 698716 | CA | 1J0819644A | VOLKSWAGEN New Beetle |
| 698716 | CA | 1J0819644A | VOLKSWAGEN Polo (99>2001) |
| 698723 | CA | 12758727 | SAAB 9-5 |
| 698724 | PA | 64311496710 | MINI Mini |
| 698725 | CA | 64311496711 | MINI Mini |
| 698730 | PA | 7701055109 | RENAULT Mégane II |
| 698731 | PA | 6447FG | CITROËN Xsara |
| 698734 | PA | 27891BM401 | NISSAN Almera |
| 698734 | PA | 27891BM401 | NISSAN Almera Tino (2003->) |
| 698734 | PA | 27891BM401 | NISSAN Primera (P12) |
| 698735 | PA | 80292S5A003 | HONDA Civic (EP) (2001->) |
| 698735 | PA | 80292S5A003 | HONDA CR-V (2002->) |
| 698736 | PA | 7701055110 | RENAULT Scénic II |
| 698737 | CA | 7701056390 | RENAULT Espace IV (2002->) |
| 698738 | PA | 6447LZ | CITROËN C8 |
| 698738 | PA | 1484383080 | FIAT Ulysse (2002->) |
| 698738 | PA | 1484383080 | LANCIA Phedra |





|  |  |  |  |
|---|---|---|---|
| 698738 | PA | 6447LY | PEUGEOT Expert (95>2004), 807 |
| 698739 | CA | 6Q0819653 | AUDI A2 |
| 698739 | CA | 6Q0819653 | SEAT Cordoba (2002->) |
| 698739 | CA | 6Q0819653 | SEAT Ibiza (2001->) |
| 698739 | CA | 6Q0819653 | SKODA Fabia |
| 698739 | CA | 6Q0819653 | VOLKSWAGEN Fox |
| 698739 | CA | 6Q0819653 | VOLKSWAGEN Polo (2001->) |
| 698740 | CA | 2118300818 | MERCEDES CLS (219) |
| 698740 | CA | 2118300818 | MERCEDES E Class (211) |
| 698741 | CA | 2118300018 | MERCEDES CLS (219) |
| 698741 | CA | 2118300018 | MERCEDES E Class (211) |
| 698742 | CA | 2038300518 | MERCEDES C Class (203) |
| 698743 | CA | 2038300918 | MERCEDES C Class (203) |
| 698744 | CA | 1688300818 | MERCEDES A Class (168) |
| 698744 | CA | 1688300818 | MERCEDES Vaneo (414) |
| 698745 | CA | 1119616 | FORD Mondeo (2000->) |
| 698745 | CA | C2S8622 | JAGUAR X-Type |
| 698746 | CA | 1808614 | OPEL Omega B (94->) |
| 698746 | CA | 9192320 | VAUXHALL Omega |
| 698747 | CA | 46799653 | ALFA ROMEO 147 |
| 698747 | CA | 46799653 | ALFA ROMEO 156 (2003->) |
| 698747 | CA | 46799653 | ALFA ROMEO GT |
| 698748 | CA | 6447PG | PEUGEOT 406 |
| 698748 | CA | 99657121902 | PORSCHE 911 (996) |
| 698748 | CA | 99657121902 | PORSCHE Boxster (986) |
| 698749 | CA | 6447PE | PEUGEOT 206, 206 CC |
| 698750 | CA | 64319071935 | BMW 3 series E46 |
| 698750 | CA | 64319071935 | BMW M3 E46 |
| 698750 | CA | 64319071935 | BMW X3 |
| 698751 | CA | 46723024 | LANCIA Thesis |
| 698753 | PA | 2727272835R | DACIA Lodgy |
| 698753 | PA | 27891AX010 | NISSAN Micra (K12) |
| 698753 | PA | 27891AX010 | NISSAN Note |
| 698753 | PA | 7701062227 | RENAULT Clio III |
| 698753 | PA | 7701062227 | RENAULT Modus |
| 698753 | PA | 7701062227 | RENAULT Twingo (2007->) |
| 698762 | PA | 4042703 | FORD Transit (2000->) |
| 698768 | CA | 7H0819631A | AUDI Q7 |
| 698768 | CA | 95557221910 | PORSCHE Cayenne |
| 698768 | CA | 7H0819631A | VOLKSWAGEN Touareg |
| 698768 | CA | 7H0819631A | VOLKSWAGEN Transporter (7J/7H) (2003->) |
| 698769 | PA | 30612666 | VOLVO S40 |
| 698769 | PA | 30612666 | VOLVO V40 |
| 698770 | PA | 9171296 | VOLVO 850 |



|  |  |  |  |
|---|---|---|---|
| 698770 | PA | 9171296 | VOLVO C70 |
| 698770 | PA | 9171296 | VOLVO S70 |
| 698770 | PA | 9171296 | VOLVO V70 (96>99) |
| 698771 | PA | 9204626 | VOLVO S60 |
| 698771 | PA | 9204626 | VOLVO S80 |
| 698771 | PA | 9204626 | VOLVO V70 (2000->) |
| 698771 | PA | 9204626 | VOLVO XC 70 |
| 698771 | PA | 9204626 | VOLVO XC 90 |
| 698772 | CA | 2108300018 | MAYBACH Maybach 57/62 |
| 698772 | CA | 2108300018 | MERCEDES CL Class (215) |
| 698772 | CA | 2108300018 | MERCEDES E Class (210) |
| 698772 | CA | 2108300018 | MERCEDES S Class (220) |
| 698773 | PA | 4705463 | OPEL Agila |
| 698773 | PA | 9586078F10 | SUBARU Justy (2003->) |
| 698773 | PA | 9586078F10 | SUZUKI Ignis |
| 698773 | PA | 9586078F10 | SUZUKI Wagon R+ |
| 698773 | PA | 9196805 | VAUXHALL Agila |
| 698774 | CA | 0001110V004 | SMART Crossblade |
| 698774 | CA | 0001110V004 | SMART Fortwo |
| 698774 | CA | 0001110V004 | SMART Smart |
| 698775 | PA | 64318409043 | BMW X5 |
| 698775 | PA | | LAND ROVER Range Rover (2002->) |
| 698776 | CA | 64318409044 | BMW X5 |
| 698776 | CA | JMO000010 | LAND ROVER Range Rover (2002->) |
| 698777 | PA | 1638350247 | MERCEDES ML Class (163) |
| 698778 | CA | 1638350047 | MERCEDES ML Class (163) |
| 698779 | PA | 1119613 | FORD Mondeo (2000->) |
| 698779 | PA | C2S8619 | JAGUAR X-Type |
| 698790 | PA | 4D0819439 | AUDI A8 (94>2002) |
| 698791 | CA | 4D0819439A | AUDI A8 (94>2002) |
| 698792 | CA | 4E0819439A | AUDI A8 (2002->) |
| 698793 | CA | 3D0898644 | BENTLEY Continental Flying Spur |
| 698793 | CA | 3D0819619A | BENTLEY Continental Flying Spur |
| 698793 | CA | 3D0898644 | BENTLEY Continental GT |
| 698793 | CA | 3D0819619A | BENTLEY Continental GT |
| 698793 | CA | 3D0898644 | BENTLEY Continental GTC |
| 698793 | CA | 3D0819619A | BENTLEY Continental GTC |
| 698793 | CA | 3D0898644 | VOLKSWAGEN Phaeton |
| 698794 | PA | 7D0819989 | VOLKSWAGEN Transporter (90>2003) |
| 698795 | PA | 8856802030 | TOYOTA Avensis (2001->) |
| 698795 | PA | 8856802030 | TOYOTA Corolla (120) (2001->) |
| 698795 | PA | 8856802030 | TOYOTA Corolla Verso (2001>2003) |
| 698796 | PA | 72880AG000 | SUBARU Legacy (2003->) |
| 698796 | PA | 8713947083 | TOYOTA Avalon, Avensis Verso (2001->) |
| 698796 | PA | 8713947083 | TOYOTA Camry |





|  |  |  |  |
|---|---|---|---|
| 698796 | PA | 8713947083 | TOYOTA Celica (ZT230) (99->) |
| 698796 | PA | 8713947083 | TOYOTA FJ Cruiser |
| 698796 | PA | 8713947083 | TOYOTA Land Cruiser (2002->) |
| 698796 | PA | 8713947083 | TOYOTA Previa (R30) (2000->) |
| 698796 | PA | 8713947083 | TOYOTA Prius (2000->) |
| 698796 | PA | 8713947083 | TOYOTA Yaris |
| 698797 | PA | | MERCEDES S Class (140) |
| 698799 | PA | JKR100200 | LAND ROVER Freelander |
| 698800 | PA | 1K0819644A | AUDI A3 (2003->) |
| 698800 | PA | 1K0819644A | SEAT Alhambra III (2010->), Altea |
| 698800 | PA | 1K0819644A | SEAT Leon II |
| 698800 | PA | 1K0819644A | SEAT Toledo (2004->) |
| 698800 | PA | 1K0819644 | SKODA Octavia (2004->) |
| 698800 | PA | 1K0819644B | SKODA Yeti |
| 698800 | PA | 1K0819644A | VOLKSWAGEN Caddy (2004->) |
| 698800 | PA | 1K0819644A | VOLKSWAGEN Eos |
| 698800 | PA | 1K0819644A | VOLKSWAGEN Golf Plus (2005->) |
| 698800 | PA | 1K0819644A | VOLKSWAGEN Golf V (2003->) |
| 698800 | PA | 1K0819644A | VOLKSWAGEN Jetta (2005->), New Beetle (2011->), Passat VII, Scirocco |
| 698800 | PA | 1K0819644B | VOLKSWAGEN Sharan III, Tiguan, Touran, Touran Héros |
| 698801 | CA | 1K1819653A | AUDI A3 (2003->) |
| 698801 | CA | 1K1819653A | SEAT Alhambra III (2010->), Leon II |
| 698801 | CA | 1K1819653A | SKODA Octavia (2004->) |
| 698801 | CA | 1K1819653B | SKODA Yeti |
| 698801 | CA | 1K1819653A | VOLKSWAGEN Caddy (2004->) |
| 698801 | CA | 1K1819653A | VOLKSWAGEN Golf Plus (2005->) |
| 698801 | CA | 1K1819653A | VOLKSWAGEN Golf V (2003->) |
| 698801 | CA | 1K1819653A | VOLKSWAGEN Jetta (2005->), New Beetle (2011->) |
| 698801 | CA | 1K1819653A | VOLKSWAGEN Passat VII |
| 698801 | CA | 1K1819653B | VOLKSWAGEN Scirocco, Tiguan, Touran, Touran Héros |
| 698802 | CA | 0013871V001 | SMART Forfour |
| 698802 | CA | 0013871V001 | SMART Roadster |
| 698802 | CA | MR958017 | MITSUBISHI Colt (2005->) |
| 698817 | PA | JKR100280 | LAND ROVER Freelander |
| 698819 | PA | 79831ST3E01 | HONDA Civic V (95>2002) |
| 698819 | PA | 79831ST3E01 | HONDA CR-V (97>2002) |
| 698819 | PA | 79831ST3E01 | HONDA Insight (2000->) |
| 698819 | PA | JKR100220 | MG MG ZS |
| 698819 | PA | JKR100220 | ROVER 400 (95->) |
| 698819 | PA | JKR100220 | ROVER 45 (2000>2004) |
| 698838 | PA | 64319069926 | BMW 7 series E38 |
| 698839 | CA | 46723245 | FIAT Doblo |
| 698839 | CA | 46723245 | FIAT Punto II |
| 698840 | PA | 9018300018 | MERCEDES Sprinter (95->) |
| 698856 | PA | 64116921018 | BMW 7 series E65/E66 |

|  |  |  |  |
|---|---|---|---|
| 698857 | CA | 64116921019 | BMW 7 series E65/E66 |
| 698858 | PA | 6447SY | CITROËN Jumper (94>2001) |
| 698858 | PA | 6447SY | CITROËN Jumper (2002>) |
| 698858 | PA | 6447SY | CITROËN Relay (94>2001) |
| 698858 | PA | 1312766080 | FIAT Ducato (94>2001) |
| 698858 | PA | 1312766080 | FIAT Ducato (2002>) |
| 698858 | PA | 6447J0 | PEUGEOT Boxer (94>2001) |
| 698858 | PA | 6447J0 | PEUGEOT Boxer (2002>) |
| 698859 | PA | 96207422 | DAEWOO Leganza |
| 698860 | PA | 96190645 | CHEVROLET Nubira |
| 698860 | PA | 96190645 | DAEWOO Nubira |
| 698861 | PA | 64316915763 | BMW Z4 |
| 698862 | CA | 64316915764 | BMW Z4 |
| 698863 | PA | 64316935822 | BMW 5 series E60/E61 |
| 698863 | PA | 64316935822 | BMW 6 series E63/E64 |
| 698864 | CA | 64316935823 | BMW 5 series E60/E61 |
| 698864 | CA | 64316935823 | BMW 6 series E63/E64 |
| 698865 | CA | 82205905 | CHRYSLER Grand Voyager (2004>) |
| 698865 | CA | 82205905 | CHRYSLER Voyager (2001>2004) |
| 698865 | CA | 82205905 | CHRYSLER Voyager (2004>) |
| 698866 | PA | 46723321 | ABARTH Nuova 500 |
| 698866 | PA | 46723321 | FIAT 500, 500C, Panda (2003>) |
| 698866 | PA | 1557375 | FORD Ka (2008>) |
| 698867 | PA | 46723331 | FIAT Doblo |
| 698867 | PA | 46723331 | FIAT Idea |
| 698867 | PA | 46723331 | FIAT Punto II |
| 698867 | PA | 46723331 | LANCIA Musa |
| 698867 | PA | 46723331 | LANCIA Y Ipsilon |
| 698868 | PA | 80292SDCA01 | HONDA Accord VIII (2003>) |
| 698869 | PA | 80290ST3E01 | HONDA Civic Aerodeck (97>) |
| 698869 | PA | 80290ST3E01 | HONDA Civic V (95>2001) |
| 698869 | PA | 80290ST3E01 | HONDA CR-V (97>2002) |
| 698869 | PA | 272774M425 | NISSAN X-Trail |
| 698870 | PA | GJ6A61P11A | MAZDA 6 (2002>) |
| 698871 | PA | 6398350247 | MERCEDES Viano |
| 698872 | CA | 6398350347 | MERCEDES Viano |
| 698873 | CA | B72003Y000 | INFINITI I30 |
| 698873 | CA | B72003Y000 | INFINITI I35 |
| 698873 | CA | 272773Y525 | NISSAN Maxima QX (A33) |
| 698874 | PA | 6808606 | OPEL Astra H (2004>) |
| 698874 | PA | 13175553 | VAUXHALL Astra (2004>) |
| 698875 | CA | 6808607 | OPEL Astra H (2004>) |
| 698875 | CA | 1718046 | OPEL Astra G |
| 698875 | CA | 13175554 | VAUXHALL Astra (2004>) |





|  |  |  |  |
|---|---|---|---|
| 698875 | CA | 9121627 | VAUXHALL Astra IV |
| 698876 | PA | 6808604 | OPEL Meriva |
| 698876 | PA | 93174800 | VAUXHALL Meriva |
| 698877 | CA | 6808605 | OPEL Meriva |
| 698877 | CA | 93174801 | VAUXHALL Meriva |
| 698878 | PA | 7701409324 | RENAULT Twingo |
| 698879 | PA | JKR000030 | MG MG ZT |
| 698879 | PA | JKR000030 | ROVER 75 |
| 698880 | PA | JKR100193 | MG MG ZT |
| 698880 | CA | JKR100193 | ROVER 75 |
| 698882 | PA | 1315686 | FORD Focus C-MAX |
| 698882 | PA | 1315686 | FORD Kuga, Mondeo (2007>) |
| 698883 | CA | 1315687 | FORD Focus C-Max, Mondeo (2007>) |
| 698883 | CA | 1415687 | FORD Kuga |
| 698884 | CA | 6447TC | CITROËN C5 (2004>) |
| 698884 | CA | 6447TC | CITROËN C6 |
| 698884 | CA | 6447RG | PEUGEOT 407 |
| 698885 | PA | 1H0819644B | AUDI A3 (96>2003) |
| 698885 | PA | 1H0819644B | SEAT Arosa |
| 698885 | PA | 1H0819644B | SEAT Cordoba (93>2002) |
| 698885 | PA | 1H0819644B | SEAT Ibiza (93>2001) |
| 698885 | PA | 1H0819644B | SEAT Inca |
| 698885 | PA | 1H0819644B | SEAT Leon |
| 698885 | PA | 1H0819644B | SEAT Toledo (98>) |
| 698885 | PA | 1H0819644B | SKODA Octavia (96>2004) |
| 698885 | PA | 1H0819644B | SKODA Superb |
| 698885 | PA | 1H0819644B | VOLKSWAGEN Bora |
| 698885 | PA | 1H0819644B | VOLKSWAGEN Caddy (95>2004) |
| 698885 | PA | 1H0819644B | VOLKSWAGEN Golf II Cabriolet |
| 698885 | PA | 1H0819644B | VOLKSWAGEN Golf III (91>97) |
| 698885 | PA | 1H0819644B | VOLKSWAGEN Golf III Cabriolet |
| 698885 | PA | 1H0819644B | VOLKSWAGEN Lupo |
| 698885 | PA | 1H0819644B | VOLKSWAGEN New Beetle (98>) |
| 698885 | PA | 1H0819644B | VOLKSWAGEN Polo (94>2001) |
| 698885 | PA | 1H0819644B | VOLKSWAGEN Vento |
| 698886 | PA | 71743821 | FIAT Sedici |
| 698886 | PA | 80291SAAE01 | HONDA Jazz (2002>) |
| 698886 | PA | 9586062J00000 | SUZUKI Swift (2005>) |
| 698886 | PA | 9586062J00000 | SUZUKI SX4 |
| 698888 | PA | 9761938100 | HYUNDAI Santa Fe |
| 698888 | PA | 9761938100 | HYUNDAI Sonata |
| 698888 | PA | 9761938100 | HYUNDAI Trajet |
| 698888 | PA | 9761938100 | HYUNDAI XG |
| 698888 | PA | 9761938100 | KIA Magentis |





|  |  |  |  |
|---|---|---|---|
| 698888 | PA | 9761938100 | KIA Sorrento |
| 698889 | PA | 971143B100 | KIA Amanti (USA) |
| 698889 | PA | 971143B100 | KIA Opirus |
| 698890 | CA | CB1261J6X | MAZDA 323 (BJ) |
| 698890 | CA | CB1261J6X | MAZDA 626 (GF) |
| 698890 | CA | CB1261J6X | MAZDA Premacy |
| 698891 | PA | GE6T61J6X | MAZDA 323 (BJ) |
| 698891 | PA | GE6T61J6X | MAZDA 626 (GF) |
| 698891 | PA | GE6T61J6X | MAZDA Premacy (2001->) |
| 698892 | PA | BP4K61J6X | MAZDA 3 |
| 698893 | PA | 4416570 | FORD Maverick (2000->) |
| 698893 | PA | EC1361J6XA | MAZDA Tribute |
| 698894 | PA | 9586165D000 | SUZUKI Grand Vitara (98->) |
| 698895 | PA | 971332F000 | KIA Cerato |
| 715500 | PA | 4F0819439 | AUDI A6 (2004->) |
| 715500 | PA | 4F0819439 | LAMBORGHINI Gallardo |
| 715501 | CA | 4F0819439A | AUDI A6 (2004->) |
| 715501 | CA | 4F0819438A | AUDI R8 |
| 715501 | CA | 4F0819439A | LAMBORGHINI Gallardo |
| 715502 | PA | 64316946629 | BMW 1 series E87 |
| 715502 | PA | 64316946629 | BMW 3 series E90 |
| 715502 | PA | 64316946629 | BMW X1 (E84) |
| 715503 | CA | 64316946628 | BMW 1 series E87 |
| 715503 | CA | 64316946628 | BMW 3 series E90 |
| 715503 | CA | 64316946628 | BMW X1 (E84) |
| 715504 | CA | C2C6884 | JAGUAR XJ (2002->) |
| 715505 | CA | XR830254 | JAGUAR S-Type |
| 715506 | PA | 1698300118 | MERCEDES A Class (169) |
| 715506 | PA | 1698300118 | MERCEDES B Class (245) |
| 715507 | CA | 1698300218 | MERCEDES A Class (169) |
| 715507 | CA | 1698300218 | MERCEDES B Class (245) |
| 715508 | CA | 1718300418 | MERCEDES SLK (171) |
| 715509 | CA | MZ360034 | MITSUBISHI Pajero III |
| 715509 | CA | MZ360034 | MITSUBISHI Pajero Pinin |
| 715510 | PA | 1354952 | FORD Focus (2004->) |
| 715510 | PA | 1354952 | FORD Turnier |
| 715511 | CA | 1395953 | FORD Focus (2004->), Turnier |
| 715512 | CA | 9171756 | VOLVO S60 |
| 715512 | CA | 9171756 | VOLVO S80 |
| 715512 | CA | 9171756 | VOLVO V70 (2000->) |
| 715512 | CA | 9171756 | VOLVO XC 70 |
| 715512 | CA | 9171756 | VOLVO XC 90 |
| 715513 | PA | 2729800QAA | NISSAN Primastar |
| 715513 | PA | 4408840 | OPEL Vivaro, Movano |





|  |  |  |  |
|---|---|---|---|
| 715513 | PA | 7701050319 | RENAULT Trafic (2001->) |
| 715513 | PA | 91160128 | VAUXHALL Vivaro, Movano |
| 715514 | PA | 5047113 | SAAB 9-3 |
| 715514 | PA | 5047113 | SAAB 900 (93->) |
| 715515 | PA | 6447TV | CITROËN C1 |
| 715515 | PA | 6447TT | PEUGEOT 107 |
| 715515 | PA | 885080H010 | TOYOTA Aygo |
| 715516 | PA | 9761037000 | HYUNDAI Accent (1999->) |
| 715516 | PA | 9761037000 | HYUNDAI Grandeur (2005->) |
| 715517 | PA | 971332D000 | HYUNDAI Coupé (2002->) |
| 715517 | PA | 971332D000 | HYUNDAI Elantra |
| 715517 | PA | 971332D000 | HYUNDAI Matrix |
| 715518 | PA | JKR500010 | LAND ROVER Discovery III |
| 715519 | CA | JKR500020 | LAND ROVER Discovery III |
| 715520 | PA | 27274EA000 | NISSAN Frontier |
| 715520 | PA | 27274EA000 | NISSAN Navarra |
| 715520 | PA | 27274EA000 | NISSAN Pathfinder (2005->) |
| 715520 | PA | 999M1D4005 | NISSAN Xterra |
| 715521 | PA | 971332E200 | HYUNDAI Tucson |
| 715521 | PA | 0K9A46452XA | KIA Sportage (2004->) |
| 715521 | PA | 971332E200 | KIA Carens III |
| 715522 | PA | 0K2FA6152X | KIA Carens II |
| 715523 | PA | 0K9A46152XA | KIA Clarus |
| 715523 | PA | 0K9A46152XA | KIA Rio |
| 715524 | PA | 9713307010 | HYUNDAI i10 |
| 715524 | PA | 9713307000 | KIA Picanto |
| 715525 | PA | 976171C000 | HYUNDAI Getz |
| 715526 | PA | 96554421 | CHEVROLET Lacetti |
| 715526 | PA | 96554421 | DAEWOO Lacetti |
| 715526 | PA | 96554421 | DAEWOO Nubira |
| 715527 | PA | 97030H1726 | HYUNDAI Terracan (HP) |
| 715528 | PA | MR315876 | MITSUBISHI Galant |
| 715529 | PA | 973043F000 | HYUNDAI Sonata (2005->) |
| 715530 | PA | 6447H0 | CITROËN Evasion |
| 715530 | PA | 6447H0 | CITROËN Jumpy |
| 715530 | PA | 6447H0 | CITROËN Synergie |
| 715530 | PA | 6447H1 | CITROËN Evasion |
| 715530 | PA | 6447H1 | CITROËN Jumpy |
| 715530 | PA | 6447H1 | CITROËN Synergie |
| 715530 | PA | 1475478080 | FIAT Scudo (95>2003) |
| 715530 | PA | 1475478080 | FIAT Ulysse (94>2002) |
| 715530 | PA | 1475479080 | FIAT Scudo (95>2003) |
| 715530 | PA | 1475479080 | FIAT Ulysse (94>2002) |
| 715530 | PA | 1475478080 | LANCIA Zeta |





|  |  |  |  |
|---|---|---|---|
| 715530 | PA | 1475479080 | LANCIA Zeta |
| 715530 | PA | 6447P2 | PEUGEOT Expert |
| 715530 | PA | 6447P2 | PEUGEOT 806 |
| 715530 | PA | 6447P3 | PEUGEOT 806 |
| 715531 | PA | 2108300018 | MAYBACH 57/62 (240) |
| 715531 | PA | 2108300018 | MERCEDES E Class (210) |
| 715531 | PA | 2108300018 | MERCEDES S Class (220) |
| 715531 | PA | 2108301018 | MERCEDES E Class (210) |
| 715532 | PA | 71754158 | ALFA ROMEO 159 |
| 715532 | PA | 71754158 | ALFA ROMEO Brera |
| 715532 | PA | 71754158 | ALFA ROMEO Spider (2006->) |
| 715533 | CA | 77363370 | ALFA ROMEO 159 |
| 715533 | CA | 77363370 | ALFA ROMEO Brera |
| 715533 | CA | 77363370 | ALFA ROMEO Spider (2006->) |
| 715534 | PA | 50580040AA | CHRYSLER PT Cruiser |
| 715535 | PA | 96539649 | CHEVROLET Aveo |
| 715535 | PA | 96539649 | CHEVROLET Kalos |
| 715535 | PA | 96539649 | DAEWOO Kalos |
| 715536 | PA | 93740495 | CHEVROLET Rezzo |
| 715536 | PA | 93740495 | CHEVROLET Tacuma |
| 715536 | PA | 93740495 | DAEWOO Rezzo |
| 715536 | PA | 93740495 | DAEWOO Tacuma |
| 715537 | CA | 5058381AA | DODGE Caliber, Journey |
| 715537 | CA | 5058381AA | JEEP Compass, Patriot |
| 715537 | CA | K05058693AA | FIAT Freemont |
| 715538 | CA | 7711228912 | NISSAN Kubistar |
| 715538 | CA | 7711228912 | RENAULT Clio II, Clio Campus Evolution (2009->) |
| 715538 | CA | 7711228912 | RENAULT Clio II (2001>2005) |
| 715538 | CA | 7711228912 | RENAULT Mégane (95>99) |
| 715538 | CA | 7711228912 | RENAULT Mégane (98>2002) |
| 715538 | CA | 7711228912 | RENAULT Thalia |
| 715538 | CA | 7711228912 | RENAULT Kangoo (97>2003) |
| 715538 | CA | 7711228912 | RENAULT Kangoo (2003->) |
| 715539 | CA | 7701064235 | RENAULT Mégane II |
| 715540 | PA | 80292SMGE01 | HONDA Civic (2006->) |
| 715541 | PA | 971333K000 | HYUNDAI Santa Fé (2006->) |
| 715541 | PA | 971333K000 | HYUNDAI Sonata (2005->) |
| 715541 | PA | 971333K000 | KIA Magentis |
| 715542 | PA | 8713930010 | LEXUS GS (97>2000) |
| 715542 | PA | 8713948020 | LEXUS LS (94>2000) |
| 715542 | PA | 8713948020 | LEXUS IS (99>2005) |
| 715542 | PA | 8713950010 | LEXUS RX (97>2003) |
| 715543 | PA | MR227823 | MITSUBISHI Lancer VI |
| 715543 | PA | MR227823 | MITSUBISHI Colt V |



|  |  |  |  |
|---|---|---|---|
| 715543 | PA | MR227823 | mitsubishi L200 |
| 715544 | CA | 1648300218 | mercedes GL Class (164) |
| 715544 | CA | 1648300218 | mercedes M Class (164) |
| 715544 | CA | 1648300218 | mercedes R Class (251) |
| 715545 | PA | XR315172 | mitsubishi Pajero Pinin |
| 715546 | PA | MR398288 | mitsubishi Grandis |
| 715546 | PA | MR398288 | mitsubishi Lancer VII (CS) |
| 715546 | PA | MR398288 | mitsubishi Outlander |
| 715547 | PA | MR360889 | mitsubishi Space Runner, Space Wagon |
| 715548 | PA | MZ311917 | mitsubishi Space Star |
| 715548 | PA | MZ311917 | mitsubishi Carisma |
| 715549 | PA | 278936F600 | nissan Micra K11 |
| 715551 | PA | 72880FE000 | subaru Impreza (G11) |
| 715552 | PA | 55702456 | alfa romeo MiTo |
| 715552 | PA | 55702456 | fiat Grande Punto, Punto Evo |
| 715552 | PA | 6808622 | opel Corsa D (2006>) |
| 715553 | CA | 55702468 | alfa romeo MiTo |
| 715553 | CA | 55702456 | fiat Grande Punto |
| 715553 | CA | 6808623 | opel Corsa D (2006>) |
| 715554 | PA | 6447XF | citroën C4 Picasso, Berlingo (2008>) |
| 715554 | PA | 6447XF | peugeot 3008 |
| 715554 | PA | 6447XF | peugeot 5008 |
| 715554 | PA | 6447XF | peugeot Partner (2008>) |
| 715555 | CA | 6447XG | citroën Berlingo II, C4 Picasso, C4 Grand Picasso, DS5 |
| 715555 | CA | 6447XG | peugeot 3008, 5008, Partner II |
| 715556 | PA | 6447VY | citroën C3, DS3 |
| 715556 | PA | 6447VY | peugeot 207, 208 |
| 715557 | CA | 6447VX | citroën C3, DS3 |
| 715557 | CA | 6447VX | peugeot 207, 208 |
| 715558 | CA | 6447SP | citroën C8 |
| 715558 | CA | 9655190480 | fiat Ulysse (2002>) |
| 715558 | CA | 9655190480 | lancia Phedra |
| 715558 | CA | 6447TA | peugeot 807 |
| 715558 | CA | 6447TA | peugeot Expert (95>2004) |
| 715559 | PA | 27277EN000 | nissan Qashqai |
| 715559 | PA | 27277EN025 | nissan Dualis, Rogue, X-trail |
| 715560 | CA | 27277CL025H | infiniti FX |
| 715560 | CA | 27277CL025H | infiniti G35 |
| 715560 | CA | 27277CL025H | nissan Altima |
| 715560 | CA | 27277Z5000 | nissan Maxima |
| 715560 | CA | 27277CL025H | nissan Murano |
| 715560 | CA | 27277CL025H | nissan X-Trail |
| 715561 | PA | 272747J125 | infiniti G20 |
| 715561 | PA | 272747J125 | infiniti QX-4 |

|  |  |  |  |
|---|---|---|---|
| 715561 | PA | 272747J125 | NISSAN Pathfinder (R50) |
| 715561 | PA | 272747J125 | NISSAN Patrol GR (Y61) |
| 715562 | PA | 7701056389 | RENAULT Espace IV (2002->) |
| 715563 | PA | G3210AE000 | SUBARU Legacy |
| 715563 | PA | G3210AE000 | SUBARU Outback |
| 715564 | PA | 9586154J00 | SUZUKI Grand Vitara |
| 715565 | PA | 8850812010 | TOYOTA Corolla (E11) |
| 715566 | PA | 6923005400 | SSANGYONG Korando |
| 715566 | PA | 6923005400 | SSANGYONG Musso Sport |
| 715566 | PA | 6923005400 | SSANGYONG Musso |
| 715567 | PA | 6923005410 | SSANGYONG Korando |
| 715567 | PA | 6923005410 | SSANGYONG Musso Sport |
| 715567 | PA | 6923005410 | SSANGYONG Musso |
| 715568 | CA | 6025372486 | RENAULT Avantime |
| 715568 | CA | 6025372486 | RENAULT Espace II, Espace III |
| 715569 | PA | 8971708040 | ISUZU Trooper |
| 715569 | PA | 1808613 | OPEL Monterey |
| 715569 | PA | 97170804 | VAUXHALL Monterey |
| 715570 | PA | 647904 | CITROËN C5 (2004->) |
| 715570 | PA | 647904 | CITROËN C6 |
| 715570 | PA | 647904 | PEUGEOT 407 |
| 715571 | CA | 9171757 | VOLVO S60 |
| 715571 | CA | 9171757 | VOLVO S80 |
| 715571 | CA | 9171757 | VOLVO V70 (2000->) |
| 715571 | CA | 9171757 | VOLVO XC 70 |
| 715571 | CA | 9171757 | VOLVO XC 90 |
| 715572 | PA | 88880-20060 | TOYOTA Avensis (T22) |
| 715572 | PA | 88880-20060 | TOYOTA Carina E |
| 715573 | PA | 79370S1AG01 | HONDA Accord (98>2003) |
| 715574 | PA | LDY461J6X | MAZDA MPV |
| 715574 | PA | LDY461J6X | MAZDA RX-8 |
| 715575 | PA | 272751N6P6 | NISSAN Almera (95>2000) |
| 715576 | PA | DC2161J6X | MAZDA Demio |
| 715577 | PA | 6388350047 | MERCEDES V Class (638) |
| 715577 | PA | 6388350047 | MERCEDES Vito (638) |
| 715578 | CA | 8D0091800 | AUDI 80 (91>95) |
| 715578 | CA | 8D0091800 | AUDI A4 (94>2000) |
| 715578 | CA | 8D0091800 | AUDI Cabriolet |
| 715578 | CA | 8D0091800 | AUDI Coupé (88>96) |
| 715578 | CA | 8D0091800 | AUDI RS4 Quattro (2000>2001) |
| 715578 | CA | 8D0091800 | AUDI S4 (97>99) |
| 715578 | CA | 8D0091800 | VOLKSWAGEN Passat (96>2000) |
| 715579 | PA | 8K0819439 | AUDI A4 (2007->) |
| 715579 | PA | 8K0819439 | AUDI A5, A5 Cabriolet (2009->) |

|  |  |  |  |
|---|---|---|---|
| 715579 | PA | 8K0819439 | AUDI Q5 |
| 715579 | PA | 8K0819439 | AUDI S4 (2008->) |
| 715579 | PA | 8K0819439 | AUDI S5 |
| 715580 | CA | 8K0819439A | AUDI A4 (2007->) |
| 715580 | CA | 8K0819439A | AUDI A5, A5 Cabriolet (2009->) |
| 715580 | CA | 8K0819439A | AUDI Q5 |
| 715580 | CA | 8K0819439A | AUDI S4 (2008->) |
| 715581 | PA | 7H0819631 | AUDI Q7 |
| 715581 | PA | 7H0819631 | VOLKSWAGEN Touareg |
| 715581 | PA | 7H0819631 | VOLKSWAGEN Caravelle |
| 715581 | PA | 7H0819631 | VOLKSWAGEN Transporter (7J/7H) (2003->) |
| 715582 | CA | 64106907746 | BMW 7 series E65/E66 |
| 715583 | PA | 64316945585 | BMW X5 E70 |
| 715583 | PA | 64316945585 | BMW X6 E71 |
| 715584 | CA | 64316945586 | BMW X5 E70 |
| 715584 | CA | 64316945586 | BMW X6 E71 |
| 715585 | PA | 64319127516 | MINI Mini (2006->), Mini 2 (R56/R57) (2009->) |
| 715586 | CA | 64319127515 | MINI Mini (2006->), Mini 2 (R56/R57) (2009->) |
| 715587 | PA | 96296618 | CHEVROLET Magnus |
| 715587 | PA | 96327366 | CHEVROLET Epica |
| 715587 | PA | 96327366 | CHEVROLET Evanda |
| 715588 | PA | 96425700 | CHEVROLET Matiz |
| 715588 | PA | 96425700 | DAEWOO Matiz |
| 715589 | PA | 6441G9 | CITROËN Saxo (96>99) |
| 715589 | PA | 644191 | PEUGEOT 106 |
| 715590 | PA | 99906-850M2-036 | DAIHATSU CUORE VII |
| 715591 | PA | 971332D200 | HYUNDAI Elantra (2000->) |
| 715592 | PA | 971331E000 | HYUNDAI Accent (2005->) |
| 715593 | PA | 80291S84A01 | HONDA Accord VII Coupe (97->) |
| 715593 | PA | 80291S84A01 | HONDA Acura CL |
| 715594 | PA | 80291S2HE01 | HONDA HR-V |
| 715594 | PA | 08R79S2H600 | HONDA HR-V |
| 715595 | PA | 3802821 | IVECO Daily (2006->) |
| 715597 | PA | LR000899 | LAND ROVER Freelander |
| 715597 | PA | 30767022 | VOLVO S60 II, S80, V60, V70 (2007->) |
| 715597 | PA | 30767022 | VOLVO XC 60, XC 70 (2007->) |
| 715598 | PA | BTR8037 | LAND ROVER Range Rover (94>2002) |
| 715599 | PA | GE7B61J6XA | MAZDA 323 (BJ) (98>2000) |
| 715599 | PA | GE7B61J6XA | MAZDA 323 (BJ) (2000>2003) |
| 715599 | PA | GE7B61J6XA | MAZDA 626 (GF) (99>2002) |
| 715599 | PA | GE7B61J6XA | MAZDA Premacy (99>2001) |
| 715600 | CA | 2048300018 | MERCEDES C Class (204) |
| 715601 | PA | 9068300218 | MERCEDES Sprinter II |
| 715601 | PA | 2E0819638 | VOLKSWAGEN Crafter |

|  |  |  |  |
|---|---|---|---|
| 715602 | CA | 9068300318 | MERCEDES Sprinter II |
| 715602 | CA | 2E0819638A | VOLKSWAGEN Crafter |
| 715603 | PA | MR958016 | MITSUBISHI Colt VI (2004->) |
| 715607 | CA | 272770001R | RENAULT Laguna III (2007->) |
| 715608 | CA | 4518300018 | SMART Fortwo |
| 715609 | PA | 9586164J00 | SUZUKI Grand Vitara III |
| 715610 | CA | 7701064237 | RENAULT Scénic II |
| 715611 | CA | 5072176AA | CHRYSLER Grand Voyager (2004->) |
| 715612 | CA | 6447LN | CITROËN Xsara Picasso |
| 715613 | PA | 6447YK | CITROËN Jumpy II |
| 715613 | PA | 1497497080 | FIAT Scudo II |
| 715613 | PA | 6447YJ | PEUGEOT Expert II |
| 715614 | CA | 6447YN | CITROËN Jumpy II |
| 715614 | CA | 1497498080 | FIAT Scudo II |
| 715614 | CA | 6447YL | PEUGEOT Expert II |
| 715615 | PA | 7082301 | FIAT Albea |
| 715615 | PA | 7082301 | FIAT Palio |
| 715615 | PA | 7082301 | FIAT Siena |
| 715615 | PA | 7082301 | FIAT Strada Pick Up |
| 715616 | PA | 77364561 | FIAT Linea |
| 715616 | PA | 77364561 | FIAT Fiorino |
| 715617 | CA | 1120475 | FORD Fiesta (95->2002) |
| 715617 | CA | 1120475 | FORD Courier, Ka, Puma |
| 715617 | CA | 410077732 | MAZDA 121 (JA/JB) (96->) |
| 715618 | PA | 0K9A56152XA | KIA Sportage (94->2004), Shuma II |
| 715619 | CA | 8713933010 | LEXUS RX 300 |
| 715619 | CA | 8713933010 | LEXUS RX 350 |
| 715619 | CA | 8713933010 | LEXUS RX 400 |
| 715619 | CA | 72880AG000 | SUBARU Legacy (2003->) |
| 715619 | CA | 72880AG000 | SUBARU Outback (2003->) |
| 715619 | CA | 72880XA000A | SUBARU Tribeca |
| 715619 | CA | 8713933010 | TOYOTA Avalon |
| 715619 | CA | 8713933010 | TOYOTA Avensis Verso (2001->) |
| 715619 | CA | 87139YZZ03 | TOYOTA 4 Runner |
| 715619 | CA | 87139YZZ03 | TOYOTA Camry |
| 715619 | CA | 87139YZZ03 | TOYOTA Sienna |
| 715620 | PA | 8713930040 | LEXUS GS (2005->) |
| 715620 | PA | 8713930040 | LEXUS IS (2005->) |
| 715620 | PA | 72880AJ000 | SUBARU Legacy |
| 715620 | PA | 72880AJ000 | SUBARU Outback |
| 715620 | PA | 8713902020 | TOYOTA Auris |
| 715620 | PA | 8713952020 | TOYOTA Avensis (T27) |
| 715620 | PA | 8713952020 | TOYOTA Land Cruiser Prado, RAV4 II (2006->) |
| 715620 | PA | 8713952020 | TOYOTA Urban Cruiser, Yaris II (2006->) |

|  |  |  |  |
|---|---|---|---|
| 715621 | CA | 2308300418 | MERCEDES SL (R230) |
| 715621 | CA | 2308300418 | MERCEDES SLR (R199) |
| 715622 | CA | 7803A027 | MITSUBISHI Pajero III (2000->) |
| 715623 | CA | 7803A043 | MITSUBISHI Lancer VIII |
| 715623 | CA | 7803A005 | MITSUBISHI Outlander (2007->) |
| 715624 | PA | 68111091A0 | SSANGYONG Actyon |
| 715624 | PA | 68111091A0 | SSANGYONG Kyron |
| 715625 | PA | 72880FG000 | SUBARU Impreza III |
| 715626 | PA | GE210FC000 | SUBARU Forester I |
| 715626 | PA | GE210FC000 | SUBARU Impreza I |
| 715627 | PA | 8687389 | VOLVO C30 |
| 715627 | PA | 8687389 | VOLVO C70 (2006->) |
| 715627 | PA | 8687389 | VOLVO S40 (2004->) |
| 715627 | PA | 8687389 | VOLVO V50 |
| 715628 | CA | 30676484 | VOLVO C30 |
| 715628 | CA | 30676484 | VOLVO C70 (2006->) |
| 715628 | CA | 30676484 | VOLVO S40 (2004->) |
| 715628 | CA | 30676484 | VOLVO V50 |
| 715629 | CA | 6447SQ | CITROËN Xsara (97>2000) |
| 715629 | CA | 6447SQ | CITROËN Berlingo (2002->) |
| 715631 | PA | 6447ZY | CITROËN C Crosser |
| 715631 | PA | B727A79925 | INFINITI FX |
| 715631 | PA | B727A79925 | INFINITI G35 |
| 715631 | PA | 7803A004 | MITSUBISHI Airtrek II |
| 715631 | PA | 7803A004 | MITSUBISHI Lancer VIII |
| 715631 | PA | 7803A004 | MITSUBISHI Outlander (2007->) |
| 715631 | PA | 27277CL025H | NISSAN Altima |
| 715631 | PA | 27277CL025H | NISSAN Maxima VI |
| 715631 | PA | 27277CL025H | NISSAN Murano |
| 715631 | PA | B727A79925 | NISSAN X-Trail (2001>2003) |
| 715631 | PA | 6447ZX | PEUGEOT 4007 |
| 715632 | CA | 1718044 | OPEL Astra F (91>98) |
| 715632 | CA | 1718044 | OPEL Calibra |
| 715632 | CA | 1718044 | OPEL Combo (93>2001) |
| 715632 | CA | 1718044 | OPEL Corsa B (93>2000), Tigra (94>2003) |
| 715632 | CA | 9121625 | VAUXHALL Astra III (91>98) |
| 715632 | CA | 9121625 | VAUXHALL Calibra |
| 715632 | CA | 9121625 | VAUXHALL Corsa I (93>2000) |
| 715632 | CA | 9121625 | VAUXHALL Tigra |
| 715632 | CA | 9121625 | VAUXHALL Combo (93>2001) |
| 715633 | PA | 7701042499 | RENAULT Kangoo (97>2003) |
| 715635 | CA | 6479-45 | CITROËN C5 II (2008) |
| 715635 | CA | 9682603680 | CITROËN C5 II (2008) |
| 715635 | CA | 647945 | CITROËN C6 |



|  |  |  |  |
|---|---|---|---|
| 715635 | CA | 647945 | PEUGEOT 407 |
| 715636 | PA | 6447YC | CITROËN Jumper |
| 715636 | PA | 77364063 | FIAT Ducato |
| 715636 | PA | 6447YA | PEUGEOT Boxer |
| 715637 | PA | 99906-850M2-038 | DAIHATSU Sirion II (01/05->) |
| 715637 | PA | 99906850M2-038 | SUBARU Justy IV |
| 715638 | PA | 97133-2L000 | HYUNDAI i30 (08/07->) |
| 715638 | PA | 971331H000 | KIA Cee'd |
| 715639 | PA | 97133-2E900 | HYUNDAI Tucson (RHD) |
| 715639 | PA | 97133-2E910 | KIA Sorento (JC) |
| 715640 | CA | C2P2410 | JAGUAR XK |
| 715640 | CA | 6W8318D483AA | JAGUAR XK |
| 715641 | CA | 87139-YZZ01 | LEXUS GS II (JZS160) |
| 715641 | CA | 87139-50030 | LEXUS LS 430 (UCF30) / SC 430 |
| 715642 | PA | D65161J6X | MAZDA 2 (10/07->) |
| 715643 | CA | 2218300018 | MERCEDES S Class (W221) 09/05-> |
| 715644 | PA | 4710210 | OPEL Agila II |
| 715644 | PA | 95860-51K00 | SUZUKI Splash |
| 715644 | PA | 93194847 | VAUXHALL Agila II |
| 715645 | PA | 1808606 | OPEL Corsa RHD, Tigra RHD |
| 715645 | PA | 90512706 | VAUXHALL Corsa, Tigra |
| 715646 | PA | 0024.84 | PEUGEOT 306 |
| 715647 | CA | 272778970R | RENAULT Mégane III, |
| 715648 | CA | 04596501AB | CHRYSLER 300 C |
| 715648 | CA | 04596501AB | DODGE Magnum |
| 715649 | PA | 7701209837 | RENAULT Kangoo II (2008) |
| 715649 | PA | 7701209837 | RENAULT Kangoo Be Bop |
| 715650 | CA | 89740-00820 | SCION xA / Xb |
| 715650 | CA | 08974-00820 | TOYOTA Echo / RAV 4 / Yaris (japan) / Yaris Verso |
| 715651 | PA | G3010-SA100 | SUBARU Forester II (09/02->) |
| 715651 | PA | 72880-SA000 | SUBARU Forester II (09/02->) |
| 715652 | PA | 95860-80J00 | SUZUKI SX4 (05/06->) |
| 715653 | PA | 191091700 | SEAT Toledo I |
| 715653 | PA | 191819638 | VOLKSWAGEN Golf Cabriolet I , Golf II , Jetta II |
| 715654 | PA | 96800069 | CHEVROLET Captiva |
| 715654 | PA | 4803883 | OPEL Antara |
| 715654 | PA | 615974 | SATURN Vue |
| 715654 | PA | 96440878 | VAUXHALL Antara |
| 715655 | PA | 589150001 | LDV Maxus |
| 715656 | PA | 9999Z-07019 | HYUNDAI Getz (A/C-) |
| 715657 | PA | TA0561J6X | MAZDA Xedos 9 (TA), Xedos 6 (CA) |
| 715658 | PA | 13271190 | CHEVROLET Cruze |
| 715658 | PA | 1808524 | OPEL Astra J, Insignia |
| 715658 | PA | 52425938 | VAUXHALL Insignia |



|  |   |  |   |
|---|---|---|---|
| 715659 | CA | 13271191 | CHEVROLET Cruze |
| 715659 | CA | 1808246 | OPEL Astra J, Insignia |
| 715659 | CA | 52420930 | VAUXHALL Insignia |
| 715660 | PA | 1541456 | FORD Fiesta |
| 715661 | CA | 1566997 | FORD Fiesta |
| 715662 | PA | 971331J000 | HYUNDAI i20 |
| 715664 | PA | BC5D61J6X | MAZDA 323 (BA) |
| 715665 | CA | 1K2 819 653 | AUDI A3 II / TT coupe / Roadster |
| 715665 | CA | 1K2819653A | SEAT Toledo III |
| 715665 | CA | 1K2819653A | SKODA Octavia II |
| 715665 | CA | 1K2 819 653 B | VOLKSWAGEN Eos, Golf Plus, Golf V, Jetta, Passat |
| 715665 | CA | 1K2 819 653 B | VOLKSWAGEN Tiguan, Touran |
| 715667 | CA | 27891JY15A | RENAULT Koleos |
| 715668 | PA | 95860-81A10 | SUZUKI Jimny |
| 715669 | PA | 97617-4H000 | HYUNDAI H1 Starex |
| 715670 | PA | 05013595AB | JEEP Cherokee II |
| 715670 | PA | 05013595AA | JEEP Cherokee III |
| 715670 | PA | 82204691 | JEEP Grand Cherokee II |
| 715670 | PA | 82208300 | JEEP Grand Cherokee III |
| 715671 | CA | 88957450 | CADILLAC CTS, SRX |
| 715672 | CA | 272771128R | RENAULT Scénic III, Grand Scénic |
| 715673 | CA | 6479K9 | PEUGEOT 508 (break/ berline) |
| 715674 | CA | 1488903 | FORD Cougar, Mondeo |
| 715675 | CA | 1808608 | OPEL Vectra B |
| 715675 | CA | 90541317 | VAUXHALL Vectra B |
| 715676 | CA | 30883952 | VOLVO S40, V40 |
| 715677 | CA | 6447SR | CITROËN Berlingo, Xsara (N1) (97>2000) |
| 715678 | CA | 80292SFY003 | HONDA Accord, Civic |
| 715678 | CA | 80292SFY003 | HONDA CR-V, Legend IV Legend IV |
| 715679 | CA | GJ6B61P11 | MAZDA 2, 6, CX7 |
| 715680 | CA | G3210FE000 | SAAB Saab 9 -2X |
| 715680 | CA | G3210FE000 | SUBARU Impreza II |
| 715681 | CA | C2Z6525 | JAGUAR XF |
| 715682 | CA | 211812202010 | LADA 110,111, 112, 2110 |
| 715683 | PA | 4A0819439A | AUDI A6 (C4), A6 (C5) |
| 715684 | PA | 1248350047 | MERCEDES E-Klasse |
| 715685 | PA | 64319069927 | BMW 5 (E39) |
| 715686 | PA | 46723435 | FIAT Bravo II, Stilo 192 |
| 715687 | PA | 9204627 | VOLVO Cross Country, S60, S80 |
| 715687 | PA | 9204627 | VOLVO V70 II, XC 90 |
| 715688 | PA | MZ311916 | MITSUBISHI Carisma |
| 715688 | PA | MR262425 | MITSUBISHI Space Star |
| 715688 | PA | 30818694 | VOLVO S40 |
| 715689 | PA | 87139YZ206 | TOYOTA Corolla IX Verso |



|  |  |  |  |
|---|---|---|---|
| 715690 | CA | 64119163329 | BMW Serie 5(F10), Serie 5 GT (F07GT) |
| 715690 | CA | 64119163329 | BMW Serie 7 (F01/F02) |
| 715691 | PA | 971332K000 | KIA Soul (2008->) |
| 715692 | PA | 80291TF0E01 | HONDA CR-Z (2010->) |
| 715692 | PA | 80291TF0E01 | HONDA Insight (2009->) |
| 715692 | PA | 80292TF0G01 | HONDA Jazz (2008->) |
| 715693 | CA | 97057362300 | PORSCHE Cayenne |
| 715694 | PA | 278914A00C | NISSAN Pixo |
| 715694 | PA | 95861M68K10 | SUZUKI Alto (2009->) |
| 715695 | CA | 08975-K2000-100 | DAIHATSU Cuore VIII |
| 715695 | CA | 08975-K2000-100 | DAIHATSU Terios |
| 715696 | PA | 68033193AA | DODGE Nitro |
| 715696 | PA | 68033193AA | JEEP Cherokee |
| 715696 | PA | 68033193AA | JEEP Liberty |
| 715697 | PA | 971333J100 | HYUNDAI ix55 (2008->) |
| 715698 | PA | 9586154G00 | SUZUKI Liana |
| 715699 | PA | 6812008030 | SSANGYONG Rexton |
| 715700 | PA | 6811021000 | SSANGYONG Rodius |
| 715701 | CA | 0897400850 | TOYOTA Avensis (T25) |
| 715701 | CA | 0897400850 | TOYOTA Corolla (120) (2001->) |
| 715701 | CA | 0897400850 | TOYOTA Corolla Verso (2001->) |
| 715702 | CA | LR000901 | LAND ROVER Freelander |
| 715702 | CA | 30767024 | VOLVO S80 |
| 715702 | CA | 30767024 | VOLVO V70 (2000->) |
| 715702 | CA | 30767024 | VOLVO V70 (2007->) |
| 715702 | CA | 30733893 | VOLVO XC 70 (2000>2007) |
| 715703 | PA | B7277JN20A | NISSAN Murano (Z51) (2008->) |
| 715703 | PA | B7277JN20A | NISSAN Teana |
| 715704 | CA | 7P0819631 | PORSCHE Cayenne (06/10->) |
| 715704 | CA | 7P0819631 | VOLKSWAGEN Touareg |
| 715705 | PA | 77365352 | ALFA ROMEO Giulietta (2010->) |
| 715706 | PA | 272771HE0E | NISSAN Micra IV |
| 715707 | PA | 95947238 | CHEVROLET Spark |
| 715708 | PA | 27891EL00A | NISSAN NV200, Tiida |
| 715709 | PA | 278911FC0A | NISSAN Cube, Leaf |
| 715710 | CA | 95215156 | CHEVROLET Spark |
| 715711 | PA | 68042866AA | CHRYSLER Grand Voyager (2008->) |
| 715712 | CA | 64319159606 | BMW 3 series (E90-E94) |
| 715713 | CA | 64319237157 | BMW X3 (F25) x Drive |
| 715714 | PA | 64319237158 | BMW X3 (F25) |
| 715715 | PA | 64119163328 | BMW 5 series (F10, F11, F18) |
| 715715 | PA | 64119163328 | BMW 6 series (F12, F13) |
| 715715 | PA | 64119163328 | BMW 7 series (F01, F02) |
| 715716 | PA | 971332B005 | HYUNDAI Santa Fe II |

|  |  |  |  |
|---|---|---|---|
| 715717 | PA | 68079487AA | JEEP Grand Cherokee IV |
| 715718 | PA | 8973561270 | ISUZU D-Max |
| 715719 | CA | 64119283497 | BMW Serie 1 & 3 (2012>) |
| 715720 | CA | 5Q0818653 | AUDI Audi A3 (2012>) |
| 715720 | CA | 5Q0818653 | VOLKSWAGEN Golf VII (2012>) |
| 715721 | PA | 272771KAQA | NISSAN Juke |
| 715721 | PA | 272772100R | RENAULT Fluence |
| 715722 | CA | 272774936R | RENAULT Fluence |
| 715723 | CA | 77365763 | FIAT Panda,500 |
| 715723 | CA | 1673744 | FORD Ka II |
| 715724 | PA | 27891.JY15A | RENAULT Koleos |
| 715725 | CA | 272770567R | RENAULT Clio IV |
| 715726 | PA | BBP261.J6X | MAZDA 3 (2008>) |
| 715727 | CA | 6R0819653 | AUDI A1 |
| 715727 | CA | 6R0819653 | SEAT Ibiza |
| 715727 | CA | 6R0819653 | SKODA Fabia, Praktik,Roomster |
| 715727 | CA | 6R0819653 | VOLKSWAGEN Polo (2010>) |
| 715728 | CA | LDY361.J6X | MAZDA MPV, RX-8 |
| 715729 | CA | 8850530100 | LEXUS GS (97>2000),IS (99>2005) |
| 715729 | CA | 8850530100 | LEXUS LS (94>2000),RX (97>2003) |
| 715729 | CA | 8850530100 | TOYOTA Harrier,Highlander I |
| 715730 | CA | 8713950060 | DAIHATSU Charade |
| 715730 | CA | 8713950060 | LEXUS CT 200h (2010>),GS (2005>) |
| 715730 | CA | 8713950060 | SUBARU Legacy,Outback,Trezia |
| 715730 | CA | 8713950060 | TOYOTA Auris, Avalon, Yaris II, Yaris III |
| 715731 | CA | 22753219 | CHEVROLET Captiva (2011>) |
| 715732 | CA | 27277JD10A | NISSAN Qashqai (2007>2010) |
| 715733 | CA | 4H0819439 | AUDI A6 (2010>),A8 (2009>),S8 (2012>) |
| 715733 | CA | 4H0819439 | BENTLEY Mulsanne |
| 715734 | CA | 272774653R | RENAULT Latitude |
| 715735 | PA | 5058693AA | CHRYSLER Sebring (2006>) |
| 715735 | PA | 5058693AA | DODGE Avenger,Caliber,Journey |
| 715735 | PA | 05058696AA | FIAT Freemont |
| 715735 | PA | 5058693AA | JEEP Compass,Patriot |
| 715735 | PA | K05058693AA | LANCIA Flavia |
| 715736 | PA | 4518350247 | SMART Fortwo |
| 715737 | PA | 6R0820367 | AUDI A1 |
| 715737 | PA | 6R0820367 | SEAT Ibiza |
| 715737 | PA | 6R0820367 | SKODA Fabia,Praktik,Roomster |
| 715737 | PA | 6R0820367 | VOLKSWAGEN Polo (2010>) |
| 715738 | PA | 974064A900 | HYUNDAI H1,H1 Mini Bus |
| 715739 | PA | 111808122010 | LADA Kalina 1118,Kalina 1119 |
| 715740 | PA | 97133-2E250 | HYUNDAI ix35, Tucson |
| 715740 | PA | 971330Z000 | KIA Sportage III |

|  |  |  |  |
|---|---|---|---|
| 715741 | PA | 971331P000 | HYUNDAI ix20 |
| 715741 | PA | 971331P000 | KIA Venga (2010->) |
| 715742 | PA | 1748480 | FORD Transit (2006->) |
| 715743 | PA | 9586157L00 | SUZUKI Kizashi Sport |
| 715744 | PA | 1S0820367 | SEAT Mii |
| 715744 | PA | 1S0820367 | SKODA Citigo |
| 715744 | PA | 1S0820367 | VOLKSWAGEN UP |
| 715745 | PA | 1718237 | FORD Ranger |
| 715745 | PA | UCY061P11 | MAZDA BT-50 II |
| 716063 | CA | 2994769 | IVECO Campagnola, Daily, Massif, Rapido |
| 715746 | PA | 272773016R | DACIA Logan II, Sandero |
| 715746 | PA | 272773016R | RENAULT Capture, Clio IV |
| 715747 | CA | 1748479 | FORD Transit 2007 |
| 715748 | PA | 97133-4P000 | HYUNDAI i20 |
| 715749 | PA | K68071668AA | LANCIA Thema II |
| 715750 | CA | DC4561J6X | MAZDA Demio |
| 715751 | PA | 1668300218 | MERCEDES GL (X166), M-Klasse (W166) |
| 715752 | CA | 1808020 | OPEL Meriva B |
| 715752 | CA | 1808020 / 13356914 | OPEL Meriva B |
| 715753 | CA | 99157362300 | PORSCHE 911 (991), Boxster/Boxster S |
| 715754 | PA | 99157237100 | PORSCHE 911 Carrera (991), Boxster |
| 715755 | PA | 51854923 | CHRYSLER Ypsilon |
| 715755 | PA | 51854923 | FIAT 500, Panda III |
| 715755 | PA | 51854923 | LANCIA Ypsilon II |
| 715756 | CA | 27277-1HE0E | NISSAN Micra |
| 715757 | CA | AV6N 19G244 AA | FORD Kuga II |
| 715757 | CA | 31369455 | VOLVO V40 II |

|  |  |
|---|---|
| ABARTH | |
| 46723321 | 698866 |
| 55702456 | 715552 |
| ALFA ROMEO | |
| 7797229 | 698199 |
| 46721923 | 698174 |
| 46799653 | 698747 |
| 60653641 | 698687 |
| 60653641 | 698197 |
| 60653642 | 698689 |
| 60801430 | 698199 |
| 60810570 | 698174 |
| 60814643 | 698688 |
| 71754158 | 715532 |
| 77363370 | 715533 |
| 77363481 | 715532 |
| 77365352 | 715705 |
| 93162491 | 698687 |
| 573228900 | 698688 |
| AUDI | |
| 1H0091800 | 698686 |
| 1H0819644 | 698159 |
| 1H0819644A | 698159 |
| 1J0819644A | 698716 |
| 1K0819644 | 698800 |
| 1K0819644A | 698800 |
| 1K1819653 | 698801 |
| 1K1819653A | 698801 |
| 1K2819653 | 715665 |
| 4A0819430A | 698682 |
| 4A0819439A | 698684 |
| 4A0819439A | 715683 |
| 4B0091800 | 698682 |
| 4B0819439A | 698682 |
| 4B0819439C | 698683 |
| 4D0819439 | 698790 |
| 4D0819439A | 698791 |
| 4E0819439A | 698792 |
| 4F0819439 | 715500 |
| 4F0819439A | 715501 |
| 4H0819439 | 715733 |
| 5Q0818653 | 715720 |
| 6Q0819653 | 698739 |
| 6Q0819653B | 698739 |

|  |  |
|---|---|
| AUDI (.../...) | |
| 6Q0820367 | 698685 |
| 6R0819653 | 715727 |
| 6R0820367 | 715737 |
| 7H0819631 | 715581 |
| 8A0819439 | 698164 |
| 8A0819439A | 698164 |
| 8D0091800 | 715578 |
| 8E0819439 | 698606 |
| 8K0819439 | 715579 |
| 8K0819439A | 715580 |
| 8L0091800 | 698686 |
| BENTLEY | |
| 3D0819619A | 698793 |
| 3D0819619B | 698793 |
| 3D0898644 | 698793 |
| 3D2819619A | 698793 |
| 3D2819620A | 698793 |
| 4H0819439 | 715733 |
| BMW | |
| 64106907746 | 715582 |
| 64110008138 | 698246 |
| 64111393489 | 698171 |
| 64116915763 | 698861 |
| 64116915764 | 698862 |
| 64116921018 | 698856 |
| 64116921019 | 698857 |
| 64116945593 | 715583 |
| 64116945594 | 715584 |
| 64118390377 | 698838 |
| 64118390447 | 698470 |
| 64118391198 | 698246 |
| 64119069895 | 698171 |
| 64119163328 | 715715 |
| 64119163329 | 715690 |
| 64119283497 | 715719 |
| 64311000004 | 698489 |
| 64311390836 | 698170 |
| 64316142114 | 715502 |
| 64316915763 | 698861 |
| 64316915764 | 698862 |
| 64316935822 | 698863 |
| 64316935823 | 698864 |
| 64316945585 | 715583 |

|  |  |
|---|---|
| BMW (.../...) | |
| 64316945586 | 715584 |
| 64316946628 | 715503 |
| 64316946629 | 715502 |
| 64316962548 | 715502 |
| 64318361899 | 698489 |
| 64318409043 | 698775 |
| 64318409044 | 698776 |
| 64319069926 | 698470 |
| 64319069926 | 698838 |
| 64319069927 | 715685 |
| 64319070072 | 698470 |
| 64319071933 | 698469 |
| 64319071934 | 698489 |
| 64319071935 | 698750 |
| 64319159606 | 715712 |
| 64319195193 | 698861 |
| 64319237157 | 715713 |
| 64319237158 | 715714 |
| 64319142114 | 715502 |
| CADILLAC | |
| 88957450 | 715671 |
| 90535131 | 698711 |
| CHEVROLET | |
| 13271190 | 715658 |
| 13271191 | 715659 |
| 22753219 | 715731 |
| 52420930 | 715659 |
| 52420938 | 715658 |
| 52425938 | 715658 |
| 93740495 | 715536 |
| 95215156 | 715710 |
| 95947238 | 715707 |
| 96296618 | 715587 |
| 96327366 | 715587 |
| 96337653 | 715587 |
| 96425700 | 715588 |
| 96435888 | 715535 |
| 96539649 | 715535 |
| 96554421 | 715526 |
| 96629614 | 715654 |
| 96800069 | 715654 |
| 96800069 | 715654 |
| 96800837 | 715526 |

|  | Valeo |
|---|--------------|
| CHEVROLET (.../...) | |
| 96830504 | 715535 |
| 96832648 | 715536 |
| EC93740495 | 715536 |
| EC96331028 | 715536 |
| CHRYSLER | |
| 82205905 | 698865 |
| 2108301218 | 698697 |
| 04596501AB | 715648 |
| 05058040AA | 715534 |
| 4596501AB | 715648 |
| 50580040AA | 715534 |
| 5058693AA | 715735 |
| 5072176AA | 715611 |
| 5101438AA | 698697 |
| 5101439AA | 698697 |
| 51854923 | 715755 |
| 68042866AA | 715711 |
| B66809901 | 698697 |
| CITROËN | |
| 647904 | 715570 |
| 647945 | 715635 |
| 95667986 | 698146 |
| 9682603680 | 715635 |
| 27277CL025H | 715631 |
| 6441G9 | 715589 |
| 6447FF | 698680 |
| 6447FG | 698731 |
| 6447H0 | 715530 |
| 6447H1 | 715530 |
| 6447HP | 698657 |
| 6447HT | 698540 |
| 6447HV | 698541 |
| 6447J0 | 698858 |
| 6447LN | 715612 |
| 6447LZ | 698738 |
| 6447NT | 698664 |
| 6447NV | 698714 |
| 6447SP | 715558 |
| 6447SQ | 715629 |
| 6447SR | 715677 |
| 6447SY | 698858 |
| 6447TC | 698884 |
| 6447TV | 715515 |

|  | Valeo |
|---|--------------|
| CITROËN (.../...) | |
| 6447XF | 715554 |
| 6447XG | 715555 |
| 6447YC | 715636 |
| 6447YK | 715613 |
| 6447YN | 715614 |
| 6447Z4 | 698146 |
| 6447ZY | 715631 |
| 6479C9 | 715636 |
| 6479E5 | 715515 |
| 6479E9 | 715623 |
| 999M1VP001 | 715631 |
| 999M1VP051 | 715631 |
| B72005M000 | 715631 |
| B727AZ5003 | 715631 |
| DACIA | |
| 7711228912 | 715538 |
| 272772835R | 698753 |
| 272772835R | 698753 |
| 272773016R | 715746 |
| DAEWOO | |
| 93740495 | 715536 |
| 96190645 | 698860 |
| 96207422 | 698859 |
| 96259613 | 698860 |
| 96425700 | 715588 |
| 96435888 | 715535 |
| 96539649 | 715535 |
| 96554421 | 715526 |
| EC96190645 | 698860 |
| EC96207422 | 698859 |
| DAIHATSU | |
| 8713950060 | 715730 |
| 08975K2000100 | 715695 |
| 99906850M2036 | 715590 |
| 99906850M2038 | 715637 |
| DODGE | |
| 04596501AB | 715648 |
| 05103600AA | 698840 |
| 5058381AA | 715537 |
| 5058693AA | 715735 |
| 68033193AA | 715696 |
| FIAT | |
| 7078711 | 698691 |

|  | Valeo |
|---|--------------|
| FIAT (.../...) | |
| 7079682 | 698690 |
| 7082301 | 715615 |
| 46409630 | 698174 |
| 46412715 | 698689 |
| 46442422 | 698197 |
| 46721374 | 698198 |
| 46722862 | 698535 |
| 46723245 | 698839 |
| 46723321 | 698866 |
| 46723331 | 698867 |
| 46723435 | 698692 |
| 46723435 | 715686 |
| 46768502 | 698687 |
| 46770829 | 698839 |
| 46770834 | 698535 |
| 46794399 | 698454 |
| 46844822 | 698710 |
| 5058696AA | 715735 |
| 51854923 | 715755 |
| 55702456 | 715552 |
| 55702456 | 715553 |
| 60811242 | 698199 |
| 60812197 | 698174 |
| 60815647 | 698687 |
| 71712595 | 698174 |
| 71712596 | 698174 |
| 71743821 | 698886 |
| 77362394 | 698867 |
| 77364063 | 715636 |
| 77364561 | 715616 |
| 77365763 | 715723 |
| 1312766080 | 698858 |
| 1475478080 | 715530 |
| 1475479080 | 715530 |
| 1484383080 | 698738 |
| 1497497080 | 715613 |
| 1497498080 | 715614 |
| 9655190480 | 715558 |
| 9586063J10 | 698886 |
| 9586063J10000 | 698886 |
| K05058693AA | 715537 |
| FORD | |
| 1004051 | 698201 |

|  | Valeo |
|---|---------------|
| FORD (.../...) | |
| 1062253 | 698487 |
| 1097670 | 698168 |
| 1113627 | 698696 |
| 1119613 | 698779 |
| 1119616 | 698745 |
| 1120475 | 715617 |
| 1121106 | 698695 |
| 1132445 | 715674 |
| 1139654 | 698695 |
| 1148366 | 698696 |
| 1204459 | 698694 |
| 1204464 | 698693 |
| 1225788 | 715674 |
| 1315686 | 698882 |
| 1315687 | 698883 |
| 1353270 | 715617 |
| 1354952 | 715510 |
| 1354953 | 715511 |
| 1382861 | 698695 |
| 1459009 | 698762 |
| 1488903 | 715674 |
| 1491752 | 698696 |
| 1541456 | 715660 |
| 1566997 | 715661 |
| 1673744 | 715723 |
| 1718237 | 715745 |
| 1748479 | 715747 |
| 1748480 | 715742 |
| 4042703 | 698762 |
| 4134237 | 698893 |
| 4416570 | 698893 |
| 5028225 | 698707 |
| 5028226 | 698707 |
| 5029916 | 698707 |
| 6797072 | 698168 |
| 7180932 | 698168 |
| 7420372 | 698247 |
| 382400304 | 698688 |
| 410077732 | 715617 |
| 1S7H16N619 | 698779 |
| 1S7H16N619AC | 698779 |
| 1X4H16N619 | 698779 |
| 1X4H19G244 | 698745 |

|  | Valeo |
|---|---------------|
| FORD (.../...) | |
| 256H19G244AA | 698693 |
| 278939F900 | 698707 |
| 7M0091800 | 698696 |
| 93BW19G244BB | 715674 |
| 94BW19N619AB | 698168 |
| 96FW19G2AA | 715617 |
| 9S5116N619AA | 698866 |
| AV6N19G244AA | 715757 |
| EC136114Y | 698893 |
| EC1361J6QA | 698893 |
| XS4H16N619AB | 698487 |
| XS4H19G244AA | 698695 |
| YC1H19N619AB | 698762 |
| YL8419N619AA | 698893 |
| YM2119N551AB | 698696 |
| HONDA | |
| 08R79S2H600 | 715594 |
| 08R79ST3600 | 698196 |
| 79370S1AG01 | 715573 |
| 79831S04003 | 698869 |
| 79831ST3E01 | 698196 |
| 79831ST3EC1 | 698196 |
| 80290SDCA01 | 715573 |
| 80290ST3E01 | 698869 |
| 80291S2HE01 | 715594 |
| 80291S5A003 | 698735 |
| 80291S84A01 | 715593 |
| 80291SAAE01 | 698886 |
| 80291ST3505 | 698869 |
| 80291ST3E01 | 698869 |
| 80291TF0E01 | 715692 |
| 80292S5A003 | 698735 |
| 80292S6DG01 | 698735 |
| 80292SCAE11 | 698735 |
| 80292SDCA01 | 698868 |
| 80292SFY003 | 715678 |
| 80292SHJA41 | 698868 |
| 80292SMGE01 | 715540 |
| 80292SWWG01 | 698868 |
| 80292TF0G01 | 715692 |
| JKR100020 | 698196 |
| HYUNDAI | |
| 9713307010 | 715524 |

|  | Valeo |
|---|---------------|
| HYUNDAI (.../...) | |
| 9761037000 | 715516 |
| 9761725000 | 715516 |
| 9761938000 | 698888 |
| 9761938100 | 698888 |
| 97030H1726 | 715527 |
| 971331E000 | 715592 |
| 971331J000 | 715662 |
| 971331J000 | 715662 |
| 971331P000 | 715741 |
| 971332B005 | 715716 |
| 971332D000 | 715517 |
| 971332D200 | 715591 |
| 971332E200 | 715521 |
| 971332E250 | 715740 |
| 971332E900 | 715639 |
| 971332L000 | 715638 |
| 971333J100 | 715697 |
| 971333K000 | 715541 |
| 971334P000 | 715748 |
| 974064A900 | 715738 |
| 976171C000 | 715525 |
| 976174H000 | 715669 |
| 976193D100 | 715529 |
| 976193D200 | 715529 |
| '976193E000 | 698888 |
| 9999Z07010 | 698888 |
| 9999Z07015 | 715517 |
| 9999Z07016 | 715527 |
| 9999Z07017 | 715525 |
| 9999Z07018 | 715591 |
| 9999Z07019 | 715656 |
| 9999Z07024 | 715591 |
| 9999Z07025 | 715541 |
| P87901F200 | 715521 |
| INFINITI | |
| 272747J125 | 715561 |
| 27277CL025H | 715560 |
| 27277Z5000 | 715560 |
| 999M1VS251 | 715560 |
| B72000W010 | 715561 |
| B72003Y000 | 698873 |
| B727A79925 | 715631 |
| B727C79925 | 715561 |

|  | Valeo |
|---|---------------|
| ISUZU | |
| 8971708040 | 715569 |
| 8973561270 | 715718 |
| 8980084420 | 715718 |
| IVECO | |
| 3802821 | 715595 |
| JAGUAR | |
| 1X4H16N619 | 698779 |
| 2W9319G244AA | 715504 |
| 6W83020B02AB | 715640 |
| 6W8318D483AA | 715640 |
| 6W8318D483AA | 715640 |
| C2C6884 | 715504 |
| C2P2410 | 715640 |
| C2S8619 | 698779 |
| C2S8622 | 698745 |
| C2Z6525 | 715681 |
| MF1455700380 | 715681 |
| XR830254 | 715505 |
| XR849205 | 715505 |
| JEEP | |
| 82204691 | 715670 |
| 82208300 | 715670 |
| 5013595AA | 715670 |
| 5013595AB | 715670 |
| 5058381AA | 715537 |
| 5058693AA | 715735 |
| 68033193AA | 715696 |
| 68079487AA | 715717 |
| KIA | |
| 9713307000 | 715524 |
| 0K2FA6152X | 715522 |
| 0K2FA6152XA | 715522 |
| 0K2N16152X | 715618 |
| 0K2N16152XA | 715618 |
| 0K2NJ6152X | 715618 |
| 0K2NJ6152XA | 715618 |
| 0K9A46152X | 715523 |
| 0K9A46152XA | 715523 |
| 971330Z000 | 715740 |
| 971331H000 | 715638 |
| 971331P000 | 715741 |
| 971332E200 | 715521 |
| 971332E910 | 715639 |

|  | Valeo |
|---|---------------|
| KIA (.../...) | |
| 971332F000 | 698895 |
| 971332K000 | 715691 |
| 971333K000 | 715541 |
| 9761938100 | 698888 |
| 976193C100 | 698888 |
| 97619FD200 | 715523 |
| 0K9A56152XA | 715618 |
| LADA | |
| 111808122010 | 715739 |
| 211812202010 | 715682 |
| LAMBORGHINI | |
| 4F0819439 | 715500 |
| 4F0819439A | 715501 |
| LANCIA | |
| 46409630 | 698174 |
| 46442422 | 698197 |
| 46721047 | 698688 |
| 46721374 | 698198 |
| 46722335 | 698688 |
| 46723024 | 698751 |
| 46723331 | 698867 |
| 51854923 | 715755 |
| 60653641 | 698687 |
| 60653641 | 698197 |
| 60811242 | 698199 |
| 60812197 | 698174 |
| 60815647 | 698687 |
| 71712595 | 698174 |
| 71712596 | 698174 |
| 77362394 | 698867 |
| 1475478080 | 715530 |
| 1475479080 | 715530 |
| 1484383080 | 698738 |
| 9655190480 | 715558 |
| K05058693AA | 715735 |
| K68071668AA | 715749 |
| LAND ROVER | |
| 30733892 | 715597 |
| 6G9N180543BA | 715597 |
| BTR8037 | 715598 |
| JKR100200 | 698799 |
| JKR100280 | 698817 |
| JKR500010 | 715518 |



|  | Valeo |
|---|---------------|
| LAND ROVER (.../...) | |
| JKR500020 | 715519 |
| JM0000010 | 698776 |
| LR000899 | 715597 |
| LR000901 | 715702 |
| LR019192 | 715597 |
| LR019589 | 715702 |
| LDV | |
| 589150001 | 715655 |
| LEXUS | |
| 8713930010 | 715542 |
| 8713930040 | 715620 |
| 8713933010 | 715619 |
| 8713948020 | 715542 |
| 8713949010 | 698796 |
| 8713950010 | 715542 |
| 8713950030 | 715641 |
| 8713950060 | 715730 |
| 8850530100 | 715542 |
| 8850530100 | 715729 |
| 8856802020 | 698796 |
| 72880AJ000 | 715620 |
| 72880XA000 | 698796 |
| 72880XA000A | 698796 |
| 871394701083 | 698796 |
| 8713950060 | 715730 |
| 87139YZZ01 | 715641 |
| 87139YZZ04 | 715542 |
| 87139YZZ08 | 715620 |
| MASERATI | |
| 382400304 | 698688 |
| 573228900 | 698688 |
| MAYBACH | |
| 2108300018 | 715531 |
| MAZDA | |
| 410077732 | 715617 |
| 1E0061J6X | 698201 |
| BBP261J6X | 715726 |
| BC5D61J6X | 715664 |
| BP4K61J6X | 698892 |
| C10261J6X | 698890 |
| CB1261J6X | 698890 |
| CB1261J6X9B | 698890 |
| CB1261J6XA9A | 698890 |



|  | Valeo |
|---|--------------|
| MAZDA (.../...) | |
| CC6461J6X | 698892 |
| D65161J6X | 715642 |
| DC2161J6X | 715576 |
| DC4561J6X | 715750 |
| DD1061P11 | 698693 |
| EC1361J6XA | 698893 |
| GE6T61J6X | 698891 |
| GE6T61J6XA9B | 698891 |
| GE7B61J6XA | 715599 |
| GJ6A61P119A | 715679 |
| GJ6A61P119B | 715679 |
| GJ6A61P11A | 698870 |
| GJ6A61P11A9B | 698870 |
| GJ6B61P11 | 715679 |
| LDY361J6X | 715728 |
| LDY461J6X | 715574 |
| TA0561J6X | 715657 |
| UCY061P11 | 715745 |
| MERCEDES | |
| 1248300118 | 715684 |
| 1248350047 | 715684 |
| 1408350047 | 698704 |
| 1408350447 | 698705 |
| 1408350547 | 698706 |
| 1638350047 | 698778 |
| 1638350047 | 698777 |
| 1638350247 | 698777 |
| 1648300218 | 715544 |
| 1668300218 | 715751 |
| 1688300018 | 698475 |
| 1688300818 | 698744 |
| 1698300118 | 715506 |
| 1698300218 | 715507 |
| 1718300418 | 715508 |
| 2028300018 | 698169 |
| 2028300318 | 698169 |
| 2038300118 | 698700 |
| 2038300218 | 698701 |
| 2038300318 | 698742 |
| 2038300518 | 698742 |
| 2038300918 | 698743 |
| 2048300018 | 715600 |
| 2108300018 | 698169 |

|  | Valeo |
|---|--------------|
| MERCEDES (.../...) | |
| 2108300018 | 715531 |
| 2108300218 | 698169 |
| 2108300618 | 698169 |
| 2108300818 | 698697 |
| 2108300918 | 698697 |
| 2108301018 | 715531 |
| 2108301118 | 698772 |
| 2108301218 | 698697 |
| 2118300018 | 698741 |
| 2118300218 | 698702 |
| 2118300818 | 698740 |
| 2208300118 | 698772 |
| 2208300218 | 698772 |
| 2218300018 | 715643 |
| 2308300418 | 715621 |
| 4638300018 | 698685 |
| 6388350047 | 715577 |
| 6398350247 | 698871 |
| 6398350347 | 698872 |
| 9018300018 | 698840 |
| 9068300218 | 715601 |
| 9068300318 | 715602 |
| 0018353047 | 715577 |
| B66809903 | 698778 |
| MG | |
| JKR000030 | 698879 |
| JKR000040 | 698880 |
| JKR100020 | 698196 |
| JKR100183 | 698879 |
| JKR100193 | 698880 |
| JKR100220 | 698819 |
| MINI | |
| 64311496710 | 698724 |
| 64311496711 | 698725 |
| 64319127515 | 715586 |
| 64319127516 | 715585 |
| MITSUBISHI | |
| 7803A004 | 715631 |
| 7803A005 | 715630 |
| 7803A027 | 715622 |
| 7803A043 | 715623 |
| MR227823 | 715543 |
| MR262425 | 715688 |

|  | Valeo |
|---|--------------|
| MITSUBISHI (.../...) | |
| MR315876 | 715528 |
| MR360889 | 715547 |
| MR398288 | 715546 |
| MR460201 | 715548 |
| MR500058 | 715509 |
| MR958016 | 715603 |
| MR958016P | 715603 |
| MR958017 | 698802 |
| MZ311916 | 715688 |
| MZ311917 | 715548 |
| MZ311917 | 715548 |
| MZ3600031 | 715547 |
| MZ3600034 | 715545 |
| MZ3600034 | 715509 |
| MZ600138 | 715547 |
| MZ600163 | 715543 |
| XR315172 | 715545 |
| XR315172D | 715545 |
| XR315586 | 715528 |
| XR315876 | 715528 |
| XR315876D | 715528 |
| XR360889 | 715547 |
| XR398288 | 715546 |
| XR398288D | 715546 |
| XR500058D | 715509 |
| XZ311917 | 715545 |
| XZ311917D | 715548 |
| NISSAN | |
| 7711228912 | 715538 |
| 271T200A00 | 715722 |
| 272747J125 | 715561 |
| 27274EA000 | 715520 |
| 272751N6P6 | 715575 |
| 2727700A26 | 715721 |
| 272771HE0E | 715706 |
| 272771HE0E | 715756 |
| 272771KA0A | 715721 |
| 272771KA4A | 715721 |
| 272773Y525 | 698873 |
| 272774M425 | 698869 |
| 27277CL025H | 715560 |
| 27277CL025H | 715631 |
| 27277EN025 | 715559 |

|  |  |
|---|---|
| NISSAN (.../...) | |
| 27277JD10A | 715732 |
| 27277Z5000 | 715560 |
| 2729800QAA | 715513 |
| 278911FC0A | 715709 |
| 278914A00C | 715694 |
| 27891AX010 | 698753 |
| 27891BM400 | 698734 |
| 27891BM401 | 698734 |
| 27891BM401KE | 698734 |
| 27891EL00A | 715708 |
| 278932F900 | 698707 |
| 278936F600 | 715549 |
| 278939F500 | 698707 |
| 999M1D4005 | 715520 |
| B72005M000 | 698869 |
| B7277JN20A | 715703 |
| B727A79925 | 698869 |
| B727A79925 | 715631 |
| B729800QAA | 698255 |
| OPEL | |
| 13271191 | 715659 |
| 13271407 | 698877 |
| 13356914 | 715752 |
| 1718042 | 698708 |
| 1718044 | 715632 |
| 1718046 | 698875 |
| 1808020 | 715752 |
| 1808246 | 715659 |
| 1808524 | 715658 |
| 1808600 | 698165 |
| 1808602 | 698165 |
| 1808604 | 698166 |
| 1808605 | 698167 |
| 1808606 | 715645 |
| 1808607 | 698202 |
| 1808608 | 715675 |
| 1808609 | 698712 |
| 1808610 | 698874 |
| 1808610 | 698662 |
| 1808612 | 698663 |
| 1808613 | 715569 |
| 1808614 | 698746 |
| 1808617 | 698710 |

|  |  |
|---|---|
| OPEL (.../...) | |
| 1808619 | 698711 |
| 1808624 | 698710 |
| 4408840 | 715513 |
| 4705463 | 698773 |
| 4710210 | 715644 |
| 4803883 | 715654 |
| 52420930 | 715659 |
| 6808601 | 698711 |
| 6808604 | 698876 |
| 6808605 | 698877 |
| 6808606 | 698874 |
| 6808607 | 698875 |
| 6808611 | 698663 |
| 6808622 | 715552 |
| 6808623 | 715553 |
| 93182437 | 698166 |
| 09207486 | 698773 |
| 9586051K00 | 715644 |
| 9586051K00000 | 715644 |
| PEUGEOT | |
| 002435 | 698749 |
| 2484 | 715646 |
| 644191 | 715589 |
| 644793 | 698235 |
| 647904 | 715570 |
| 647989 | 698713 |
| 6447AZ | 698488 |
| 6447GW | 698713 |
| 6447J0 | 698858 |
| 6447KK | 698664 |
| 6447KL | 698714 |
| 6447KR | 698657 |
| 6447LY | 698738 |
| 6447P2 | 715530 |
| 6447P3 | 715530 |
| 6447PE | 698749 |
| 6447PG | 698748 |
| 6447RG | 698884 |
| 6447S5 | 698203 |
| 6447SY | 698858 |
| 6447TA | 715558 |
| 6447TT | 715515 |
| 6447VX | 715557 |

|  |  |
|---|---|
| PEUGEOT (.../...) | |
| 6447VY | 715556 |
| 6447YA | 715636 |
| 6447YJ | 715613 |
| 6447YL | 715614 |
| 6447Z5 | 698146 |
| 6447ZX | 715631 |
| 6479K9 | 715673 |
| 85601415 | 698713 |
| PORSCHE | |
| 95557221910 | 698768 |
| 95857221900 | 715704 |
| 97057362300 | 715693 |
| 99157237100 | 715754 |
| 99157362300 | 715753 |
| 99657121901 | 698203 |
| 99657121902 | 698748 |
| 99657121903 | 698748 |
| 99657221901 | 698203 |
| 99757121900 | 698748 |
| RENAULT | |
| 272770001R | 715607 |
| 272770567R | 715725 |
| 272771128R | 715672 |
| 272772100R | 715721 |
| 272773016R | 715746 |
| 272774653R | 715734 |
| 272774658R | 715724 |
| 272774936R | 715722 |
| 272775374R | 698753 |
| 272778970R | 715647 |
| 27891JY15A | 715667 |
| 27891JY15A | 715724 |
| 52419600 | 715607 |
| 52485325 | 698594 |
| 6025370624 | 698290 |
| 6025372486 | 715568 |
| 7700424093 | 698276 |
| 7700424098 | 698255 |
| 7700428820 | 698279 |
| 7700834816 | 698173 |
| 7700845219 | 698176 |
| 7700845222 | 698177 |
| 7700845811 | 698149 |

|  | Valeo |
|---|---------------|
| RENAULT (.../...) | |
| 7700846236 | 698175 |
| 7701040543 | 698149 |
| 7701042499 | 698255 |
| 7701042499 | 715633 |
| 7701044813 | 698255 |
| 7701047513 | 698512 |
| 7701048748 | 698594 |
| 7701048749 | 698715 |
| 7701050319 | 715513 |
| 7701055109 | 698730 |
| 7701055110 | 698736 |
| 7701056389 | 715562 |
| 7701056390 | 698737 |
| 7701059997 | 698753 |
| 7701062227 | 698753 |
| 7701064235 | 715539 |
| 7701064237 | 715610 |
| 7701205278 | 698149 |
| 7701205279 | 698176 |
| 7701205280 | 698175 |
| 7701205281 | 698177 |
| 7701209837 | 715649 |
| 7701409324 | 698878 |
| 7711228912 | 715538 |
| ROLLS ROYCE | |
| 64116921019 | 698857 |
| ROVER | |
| JKR000030 | 698879 |
| JKR000040 | 698880 |
| JKR100020 | 698196 |
| JKR100183 | 698879 |
| JKR100193 | 698880 |
| JKR100220 | 698819 |
| SAAB | |
| 4541546 | 698723 |
| 5047113 | 715514 |
| 5335948 | 698723 |
| 5335955 | 698723 |
| 9179904 | 698711 |
| 9179905 | 698710 |
| 9625674 | 698199 |
| 12758727 | 698723 |
| 93172129 | 698711 |



|  | Valeo |
|---|---------------|
| SAAB (.../...) | |
| 72880FE001 | 715551 |
| G3210FE000 | 715680 |
| SATURN | |
| 615974 | 715654 |
| SCION | |
| 8713952010 | 698681 |
| 8974000820 | 715650 |
| 885685201083 | 698681 |
| SEAT | |
| 191091700 | 715653 |
| 191819638 | 715653 |
| 1H0091800 | 698686 |
| 1H0819638 | 698160 |
| 1H0819638A | 698160 |
| 1H0819644 | 698159 |
| 1H0819644A | 698159 |
| 1H0819644B | 698159 |
| 1J0819644 | 698716 |
| 1K0819644 | 698800 |
| 1K0819644A | 698800 |
| 1K1819653A | 698801 |
| 1K2819653A | 715665 |
| 1S0820367 | 715744 |
| 6Q0819653 | 698739 |
| 6Q0819653B | 698739 |
| 6Q0820367 | 698685 |
| 6R0819653 | 715727 |
| 6R0820367 | 715737 |
| 7H0819638A | 698247 |
| 7M0091800 | 698696 |
| 7M0819644 | 698247 |
| 7M3819644 | 698696 |
| 8L0091800 | 698686 |
| SKODA | |
| 1H0091800 | 698686 |
| 1H0819644 | 698159 |
| 1H0819644A | 698159 |
| 1H0819644B | 698159 |
| 1J0819644A | 698716 |
| 1K0819644 | 698800 |
| 1K1819653 | 698801 |
| 1K1819653A | 698801 |
| 1K2819653A | 715665 |

|  | Valeo |
|---|---------------|
| SKODA (.../...) | |
| 1S0820367 | 715744 |
| 6Q0819653 | 698739 |
| 6Q0819653B | 698739 |
| 6Q0820367 | 698685 |
| 6R0819653 | 715727 |
| 6R0820367 | 715737 |
| 8L0091800 | 698686 |
| SMART | |
| 4518300018 | 715608 |
| 4518350247 | 715736 |
| 0001110V003 | 698774 |
| 0001110V004 | 698774 |
| 0013871V001 | 698802 |
| SSANGYONG | |
| 6811021000 | 715700 |
| 6812008030 | 715699 |
| 6923005400 | 715566 |
| 6923005410 | 715567 |
| 68111091A0 | 715624 |
| SUBARU | |
| 72880AE090 | 715563 |
| 72880AG000 | 715619 |
| 72880AJ000 | 715620 |
| 72880FE000 | 715551 |
| 72880FG000 | 715625 |
| 72880SA000 | 715651 |
| 72880XA000A | 715619 |
| 8713950060 | 715730 |
| G210FC000 | 715626 |
| G3010SA100 | 715651 |
| G3210AE000 | 715563 |
| G3210FE000 | 715680 |
| GE210FC000 | 715626 |
| SUZUKI | |
| 586154G000 | 698681 |
| 9586051K00 | 715644 |
| 9586062J000 | 698886 |
| 9586078F10 | 698773 |
| 9586080J00 | 715652 |
| 9586081A10 | 715668 |
| 9586154G00 | 715698 |
| 9586154J00 | 715564 |
| 9586157L00 | 715743 |

|  | Valeo |
|---|---------------|
| SUZUKI (.../...) | |
| 9586164J00 | 715609 |
| 9586165D000 | 698894 |
| 95861M68K10 | 715694 |
| 99000990NOF10 | 698894 |
| 99000990NOF30 | 698894 |
| 99000990NOF40 | 698894 |
| TOYOTA | |
| 897400820 | 715619 |
| 897400820 | 715650 |
| 897400850 | 715701 |
| 8713902020 | 715620 |
| 8713932010 | 715620 |
| 8713933010 | 715619 |
| 8713947010 | 698796 |
| 871394701083 | 698796 |
| 8713947083 | 698796 |
| 8713949010 | 698796 |
| 8713950060 | 715730 |
| 8713952010 | 698681 |
| 8713952020 | 715620 |
| 8850530100 | 715729 |
| 8850812010 | 715565 |
| 8850812030 | 715565 |
| 8856802030 | 698795 |
| 8856852010 | 698681 |
| 8888020060 | 715572 |
| 8888020080 | 715572 |
| 8888020130 | 715572 |
| 87139YZZ03 | 715619 |
| 87139YZZ06 | 715689 |
| 87139YZZ07 | 698795 |
| 87139YZZ08 | 715620 |
| 885080H010 | 715515 |
| VAUXHALL | |
| 9118699 | 698708 |
| 9121625 | 715632 |
| 9121627 | 698875 |
| 9192320 | 698746 |
| 9196805 | 698773 |
| 9200067 | 698165 |
| 13175553 | 698874 |
| 13175554 | 698875 |
| 52420930 | 715659 |

|  | Valeo |
|---|---------------|
| VAUXHALL (.../...) | |
| 52425938 | 715658 |
| 52470574 | 698712 |
| 55702456 | 715552 |
| 55702468 | 715553 |
| 90386776 | 698166 |
| 90486282 | 698165 |
| 90509367 | 698166 |
| 90510338 | 698167 |
| 90512706 | 715645 |
| 90512779 | 698202 |
| 90520689 | 698662 |
| 90541317 | 715675 |
| 90559549 | 698663 |
| 91132359 | 698875 |
| 91132364 | 698708 |
| 91160128 | 715513 |
| 93172129 | 698710 |
| 93172299 | 698711 |
| 93174800 | 698876 |
| 93174801 | 698877 |
| 93182436 | 698663 |
| 93194847 | 715644 |
| 96440878 | 715654 |
| 97170804 | 715569 |
| VOLKSWAGEN | |
| 191091700 | 715653 |
| 191819638 | 715653 |
| 357819638 | 698163 |
| 1H0091800 | 698686 |
| 1H0819638 | 698160 |
| 1H0819638A | 698160 |
| 1H0819644 | 698159 |
| 1H0819644A | 698159 |
| 1H0819644A | 698679 |
| 1H0819644B | 698159 |
| 1J0819644 | 698716 |
| 1J0819644A | 698716 |
| 1K0819644 | 698800 |
| 1K0819644A | 698800 |
| 1K1819653 | 698801 |
| 1K1819653A | 698801 |
| 1K2819653B | 715665 |
| 1S0820367 | 715744 |

|  | Valeo |
|---|---------------|
| VOLKSWAGEN (.../...) | |
| 2E0819638 | 715601 |
| 2E0819638A | 715602 |
| 3A0819638 | 698163 |
| 3A0819644 | 698163 |
| 3D0898644 | 698793 |
| 5Q0818653 | 715720 |
| 6Q0819653 | 698739 |
| 6Q0819653B | 698739 |
| 6Q0820367 | 698685 |
| 6R0819653 | 715727 |
| 6R0820367 | 715737 |
| 7D0819989 | 698794 |
| 7H0819631 | 715581 |
| 7H0819631A | 698768 |
| 7M0091800 | 698696 |
| 7M0819638A | 698247 |
| 7M0819644 | 698247 |
| 7M3819644 | 698696 |
| 7M3819644A | 698696 |
| 7P0819631 | 715704 |
| 8A0819439A | 698164 |
| 8L0091800 | 698686 |
| VOLVO | |
| 8687389 | 715627 |
| 9171296 | 698770 |
| 9171756 | 715512 |
| 9171757 | 715571 |
| 9204626 | 698771 |
| 9204627 | 715687 |
| 30612666 | 698769 |
| 30662349 | 715676 |
| 30733893 | 715702 |
| 30767022 | 715597 |
| 30767024 | 715702 |
| 30780377 | 715628 |
| 30818694 | 715688 |
| 30883952 | 715676 |
| 31369455 | 715757 |

|  |  |
|---|---|
| BOSCH | |
| 1235522053 | 698594 |
| 1423429008 | 698175 |
| 1987431001 | 698169 |
| 1987431002 | 698171 |
| 1987431003 | 698197 |
| 1987431005 | 698199 |
| 1987431006 | 698201 |
| 1987431007 | 698203 |
| 1987431009 | 698149 |
| 1987431009 | 698276 |
| 1987431010 | 698165 |
| 1987431012 | 698159 |
| 1987431012 | 698160 |
| 1987431013 | 698163 |
| 1987431014 | 698174 |
| 1987431015 | 698166 |
| 1987431016 | 698167 |
| 1987431017 | 698164 |
| 1987431018 | 698168 |
| 1987431019 | 698198 |
| 1987431021 | 698146 |
| 1987431022 | 698235 |
| 1987431027 | 698173 |
| 1987431028 | 698247 |
| 1987431030 | 698202 |
| 1987431031 | 715645 |
| 1987431032 | 698170 |
| 1987431034 | 698177 |
| 1987431035 | 698169 |
| 1987431036 | 698489 |
| 1987431037 | 698475 |
| 1987431038 | 698663 |
| 1987431038 | 698708 |
| 1987431039 | 698255 |
| 1987431040 | 698662 |
| 1987431042 | 698858 |
| 1987431043 | 698840 |
| 1987431045 | 698487 |
| 1987431046 | 698172 |
| 1987431048 | 698488 |
| 1987431049 | 698290 |
| 1987431052 | 698712 |
| 1987431053 | 698869 |

|  |  |
|---|---|
| BOSCH (.../...) | |
| 1987431054 | 698680 |
| 1987431055 | 698196 |
| 1987431057 | 698685 |
| 1987431058 | 698707 |
| 1987431059 | 698454 |
| 1987431060 | 715530 |
| 1987431061 | 698279 |
| 1987431062 | 698770 |
| 1987431063 | 698769 |
| 1987431064 | 698771 |
| 1987431066 | 698773 |
| 1987431070 | 698700 |
| 1987431071 | 698606 |
| 1987431072 | 698535 |
| 1987431073 | 698779 |
| 1987431075 | 698734 |
| 1987431076 | 698711 |
| 1987431082 | 698724 |
| 1987431084 | 698681 |
| 1987431085 | 698796 |
| 1987431090 | 698276 |
| 1987431092 | 698870 |
| 1987431095 | 698878 |
| 1987431096 | 715514 |
| 1987431102 | 698863 |
| 1987431103 | 698856 |
| 1987431106 | 698866 |
| 1987431111 | 698876 |
| 1987431113 | 715510 |
| 1987431300 | 698716 |
| 1987431301 | 698697 |
| 1987431303 | 698687 |
| 1987431307 | 698748 |
| 1987431312 | 698686 |
| 1987431324 | 698606 |
| 1987431328 | 698696 |
| 1987431333 | 698684 |
| 1987431335 | 698697 |
| 1987431336 | 698750 |
| 1987431337 | 698744 |
| 1987431345 | 698695 |
| 1987431346 | 698778 |
| 1987431357 | 698739 |

|  |  |
|---|---|
| BOSCH (.../...) | |
| 1987431360 | 698688 |
| 1987431361 | 698246 |
| 1987431362 | 698470 |
| 1987431364 | 698777 |
| 1987431365 | 698867 |
| 1987431366 | 698746 |
| 1987431370 | 698743 |
| 1987431371 | 698683 |
| 1987431373 | 698745 |
| 1987431376 | 698710 |
| 1987431377 | 698692 |
| 1987431378 | 698774 |
| 1987431379 | 698714 |
| 1987431380 | 698715 |
| 1987431382 | 698725 |
| 1987431386 | 698747 |
| 1987431387 | 698693 |
| 1987431398 | 698541 |
| 1987431399 | 698713 |
| 1987431401 | 698723 |
| 1987431402 | 698864 |
| 1987431409 | 698883 |
| 1987431410 | 715507 |
| 1987431411 | 698877 |
| 1987431412 | 698884 |
| 1987431413 | 715511 |
| 1987431551 | 715516 |
| 1987431552 | 698889 |
| 1987431554 | 715591 |
| 1987431557 | 698887 |
| 1987431562 | 715536 |
| 1987431565 | 715699 |
| 1987431568 | 715566 |
| 1987431571 | 715535 |
| 1987431953 | 715550 |
| 1987432001 | 698169 |
| 1987432004 | 715658 |
| 1987432006 | 715617 |
| 1987432009 | 698149 |
| 1987432012 | 698159 |
| 1987432020 | 715531 |
| 1987432024 | 715683 |
| 1987432026 | 698819 |

**Valeo****BOSCH (.../...)**



| | |
|------------|---------------|
| 1987432027 | 698173 |
| 1987432034 | 715603 |
| 1987432037 | 698475 |
| 1987432040 | 698709 |
| 1987432040 | 698874 |
| 1987432041 | 715646 |
| 1987432043 | 698840 |
| 1987432044 | 715577 |
| 1987432049 | 698290 |
| 1987432051 | 715684 |
| 1987432056 | 698794 |
| 1987432058 | 698707 |
| 1987432061 | 698276 |
| 1987432061 | 715685 |
| 1987432065 | 715636 |
| 1987432066 | 698773 |
| 1987432068 | 698861 |
| 1987432069 | 698512 |
| 1987432070 | 698700 |
| 1987432077 | 698731 |
| 1987432078 | 715649 |
| 1987432079 | 698664 |
| 1987432081 | 698702 |
| 1987432083 | 698657 |
| 1987432085 | 715619 |
| 1987432087 | 698694 |
| 1987432088 | 698795 |
| 1987432089 | 698177 |
| 1987432090 | 698279 |
| 1987432091 | 698738 |
| 1987432093 | 698730 |
| 1987432094 | 698736 |
| 1987432095 | 698878 |
| 1987432097 | 698800 |
| 1987432100 | 715562 |
| 1987432103 | 698857 |
| 1987432105 | 698860 |
| 1987432107 | 698691 |
| 1987432108 | 698690 |
| 1987432109 | 698882 |
| 1987432113 | 715627 |
| 1987432114 | 715581 |
| 1987432115 | 698886 |

**Valeo****BOSCH (.../...)**



| | |
|------------|---------------|
| 1987432118 | 715575 |
| 1987432119 | 715549 |
| 1987432120 | 698753 |
| 1987432124 | 715502 |
| 1987432132 | 715662 |
| 1987432133 | 715532 |
| 1987432134 | 715543 |
| 1987432137 | 715554 |
| 1987432148 | 715694 |
| 1987432154 | 715589 |
| 1987432155 | 715565 |
| 1987432156 | 715668 |
| 1987432157 | 715688 |
| 1987432158 | 715517 |
| 1987432159 | 715572 |
| 1987432160 | 715529 |
| 1987432161 | 715525 |
| 1987432162 | 715664 |
| 1987432163 | 698892 |
| 1987432164 | 715524 |
| 1987432164 | 715666 |
| 1987432167 | 715594 |
| 1987432169 | 715598 |
| 1987432170 | 715521 |
| 1987432171 | 715588 |
| 1987432172 | 715698 |
| 1987432175 | 698859 |
| 1987432176 | 715523 |
| 1987432182 | 698879 |
| 1987432183 | 715615 |
| 1987432184 | 715534 |
| 1987432188 | 715552 |
| 1987432188 | 715553 |
| 1987432189 | 715515 |
| 1987432192 | 698762 |
| 1987432193 | 715633 |
| 1987432194 | 715520 |
| 1987432195 | 698871 |
| 1987432197 | 715538 |
| 1987432198 | 698540 |
| 1987432203 | 715540 |
| 1987432205 | 715597 |
| 1987432207 | 715528 |

**Valeo****BOSCH (.../...)**

| | |
|------------|---------------|
| 1987432208 | 715513 |
| 1987432210 | 698799 |
| 1987432211 | 715618 |
| 1987432213 | 715601 |
| 1987432213 | 715602 |
| 1987432214 | 715644 |
| 1987432215 | 715660 |
| 1987432218 | 715626 |
| 1987432219 | 715583 |
| 1987432220 | 698735 |
| 1987432221 | 715564 |
| 1987432222 | 715654 |
| 1987432225 | 698176 |
| 1987432227 | 715541 |
| 1987432228 | 715616 |
| 1987432234 | 715692 |
| 1987432235 | 715518 |
| 1987432236 | 715609 |
| 1987432238 | 715559 |
| 1987432240 | 715697 |
| 1987432270 | 698701 |
| 1987432296 | 715585 |
| 1987432296 | 715586 |
| 1987432301 | 698697 |
| 1987432304 | 715659 |
| 1987432306 | 715617 |
| 1987432309 | 715544 |
| 1987432310 | 715632 |
| 1987432311 | 715635 |
| 1987432315 | 715690 |
| 1987432317 | 715578 |
| 1987432318 | 715674 |
| 1987432319 | 715641 |
| 1987432324 | 698682 |
| 1987432326 | 715600 |
| 1987432327 | 715647 |
| 1987432328 | 698696 |
| 1987432330 | 715675 |
| 1987432337 | 698744 |
| 1987432348 | 698749 |
| 1987432354 | 715612 |
| 1987432362 | 698838 |
| 1987432363 | 715676 |

|  |  |
|---|---|
| BOSCH (.../...) | |
| 1987432364 | 698777 |
| 1987432364 | 698778 |
| 1987432365 | 698839 |
| 1987432367 | 698791 |
| 1987432368 | 698862 |
| 1987432369 | 715580 |
| 1987432370 | 698743 |
| 1987432371 | 698683 |
| 1987432380 | 698715 |
| 1987432381 | 698741 |
| 1987432393 | 715539 |
| 1987432394 | 715610 |
| 1987432397 | 698801 |
| 1987432400 | 698737 |
| 1987432405 | 715702 |
| 1987432406 | 715613 |
| 1987432406 | 715614 |
| 1987432410 | 715507 |
| 1987432413 | 715628 |
| 1987432415 | 715661 |
| 1987432416 | 715623 |
| 1987432416 | 715630 |
| 1987432419 | 715584 |
| 1987432422 | 715501 |
| 1987432423 | 698792 |
| 1987432424 | 715503 |
| 1987432425 | 698776 |
| 1987432426 | 715546 |
| 1987432428 | 715505 |
| 1987432431 | 698768 |
| 1987432433 | 715533 |
| 1987432434 | 698802 |
| 1987432435 | 715682 |
| 1987432436 | 715556 |
| 1987432436 | 715557 |
| 1987432437 | 715555 |
| 1987432464 | 715512 |
| 1987432468 | 715542 |
| 1987432482 | 698880 |
| 1987432495 | 698872 |
| 1987432497 | 698865 |
| 1987432498 | 715509 |
| 1987432499 | 715608 |

|  |  |
|---|---|
| BOSCH (.../...) | |
| 1987432500 | 715607 |
| 1987432512 | 698740 |
| 1987432533 | 698772 |
| 1987432597 | 715665 |
| 2914551117 | 698817 |
| 0986477134 | 715500 |
| 0986AF4002 | 715526 |
| 0986AF4003 | 715700 |
| 0986AF4008 | 715522 |
| 0986AF4009 | 715521 |
| 0986AF4010 | 698895 |
| 0986AF4011 | 715624 |
| 0986AF4099 | 715643 |
| 0986AF4151 | 698888 |
| 0986AF4163 | 715592 |
| 0986AF4186 | 715639 |
| 0986AF4187 | 715669 |
| 0986AF4189 | 715638 |
| 0986AF5008 | 715679 |
| 0986AF5028 | 715631 |
| 0986AF5164 | 715620 |
| 0986AF5169 | 715574 |
| 0986AF5403 | 715653 |
| 0986AF5415 | 698891 |
| 0986AF5431 | 698800 |
| 0986AF5432 | 698801 |
| 0986AF5433 | 715501 |
| COOPERS | |
| ACE003 | 698165 |
| ACE004 | 698146 |
| ACE005 | 698164 |
| ACE006 | 698159 |
| ACE008 | 698166 |
| ACE009 | 698199 |
| ACE010 | 698169 |
| ACE012 | 698203 |
| ACE015 | 698149 |
| ACE015 | 698738 |
| ACE016 | 698247 |
| ACE017 | 698201 |
| ACE020 | 698202 |
| ACE021 | 698235 |
| ACE023 | 698171 |

|  |  |
|---|---|
| COOPERS (.../...) | |
| ACE024 | 698174 |
| ACE026 | 698197 |
| ACE027 | 698198 |
| ACE028 | 698167 |
| ACE029 | 698276 |
| ACE032 | 715531 |
| ACE033 | 698770 |
| ACE034 | 698475 |
| ACE035 | 698723 |
| ACE036 | 698487 |
| ACE037-2 | 698290 |
| ACE039 | 715632 |
| ACE040 | 698682 |
| ACE041 | 698697 |
| ACE042 | 698696 |
| ACE043 | 715675 |
| ACE047 | 698716 |
| ACE048 | 698686 |
| ACE054 | 698731 |
| ACE055 | 698255 |
| ACE056 | 715578 |
| ACE057 | 698454 |
| ACE058 | 715577 |
| ACE061 | 698170 |
| ACE062 | 698173 |
| ACE063 | 698196 |
| ACE064 | 698663 |
| ACE065 | 698662 |
| ACE067 | 715530 |
| ACE068 | 698840 |
| ACE069 | 698488 |
| ACE070 | 698773 |
| ACE071 | 698769 |
| ACE072 | 698707 |
| ACE073 | 698680 |
| ACE076 | 698681 |
| ACE077 | 698762 |
| ACE079 | 698879 |
| ACE080 | 715617 |
| ACE082 | 715565 |
| ACE083 | 698693 |
| ACE085 | 715598 |
| ACE086 | 698710 |

**Valeo****COOPERS (.../...)**

| | |
|----------|--------|
| ACE087 | 698606 |
| ACE088 | 698724 |
| ACE089 | 698685 |
| ACE090 | 698739 |
| ACE091 | 715645 |
| ACE092 | 698689 |
| ACE094 | 698888 |
| ACE096 | 698714 |
| ACE097-2 | 698747 |
| ACE098 | 698694 |
| ACE099 | 698799 |
| ACE100 | 698794 |
| ACE102 | 698882 |
| ACE103 | 698168 |
| ACE104 | 698163 |
| ACE105 | 698541 |
| ACE106 | 698734 |
| ACE107 | 698859 |
| ACE109 | 698175 |
| ACE110 | 698715 |
| ACE112 | 698753 |
| ACE113-2 | 698735 |
| ACE114 | 698777 |
| ACE115-2 | 698246 |
| ACE116 | 698750 |
| ACE118 | 698870 |
| ACE119-2 | 715536 |
| ACE120 | 698796 |
| ACE121 | 698657 |
| ACE122 | 715562 |
| ACE123 | 698737 |
| ACE124 | 715581 |
| ACE125 | 698800 |
| ACE126 | 715573 |
| ACE127 | 698692 |
| ACE128 | 715688 |
| ACE129 | 715572 |
| ACE130 | 698795 |
| ACE131 | 715571 |
| ACE132 | 715513 |
| ACE133 | 698801 |
| ACE134 | 698839 |
| ACE135 | 698876 |



**Valeo****COOPERS (.../...)**



| | |
|----------|--------|
| ACE137 | 698884 |
| ACE138 | 715631 |
| ACE139 | 698730 |
| ACE141 | 698736 |
| ACE144 | 715515 |
| ACE145 | 715506 |
| ACE147 | 715514 |
| ACE148 | 698868 |
| ACE149-2 | 698864 |
| ACE154 | 698866 |
| ACE156 | 715503 |
| ACE158 | 715510 |
| ACE160 | 698817 |
| ACE162-2 | 698740 |
| ACE164 | 715687 |
| ACE166 | 715533 |
| ACE169-2 | 715557 |
| ACE171-2 | 715501 |
| ACE172 | 715521 |
| ACE173-2 | 698892 |
| ACE185 | 715550 |
| ACE186 | 715689 |
| ACE187 | 715558 |
| ACE192 | 715517 |
| ACE194 | 715553 |
| ACE195 | 715613 |
| ACE196 | 698886 |
| ACE197 | 715541 |
| ACE198 | 698741 |
| ACE201 | 715519 |
| ACE204-2 | 715555 |
| ACE205 | 715636 |
| ACE206 | 715552 |
| ACE207 | 715580 |
| ACE208 | 715540 |
| ACE209 | 715638 |
| ACE210-2 | 715607 |
| ACE211 | 698725 |
| ACE215-2 | 715642 |
| ACE220-2 | 715554 |
| ACE223-2 | 715525 |
| PC8038 | 698177 |
| PC8051 | 698858 |

**Valeo****COOPERS (.../...)**

| | |
|----------|--------|
| PC8053 | 698489 |
| PC8061 | 698176 |
| PC8075 | 698512 |
| PC8085 | 698771 |
| PC8087 | 698860 |
| PC8112 | 698878 |
| PC8147 | 698700 |
| PC8153 | 715570 |
| PC8174 | 715532 |
| PC8197 | 715597 |
| PC8199 | 715601 |
| PC8200 | 715616 |
| PC8209 | 715579 |
| PC8215 | 715526 |
| PC8217-2 | 715649 |
| PC8225 | 715595 |
| PC8228 | 715724 |
| PC8230 | 698871 |
| PC8241-2 | 715556 |
| PC8248 | 715524 |
| PC8250 | 715660 |
| PC8254 | 715542 |
| PC8255 | 715658 |
| PC8256 | 715691 |
| PC8257 | 715694 |
| PC8263 | 715585 |
| PC8264 | 715721 |
| PC8265 | 715654 |
| PC8269-2 | 715662 |
| PC8279 | 698664 |
| PC8290 | 715705 |
| PC8297 | 715559 |
| PC8298 | 715706 |
| PC8303-2 | 715523 |
| PCK8003 | 715677 |
| PCK8020 | 698748 |
| PCK8036 | 698688 |
| PCK8043 | 698695 |
| PCK8059 | 715538 |
| PCK8060 | 698749 |
| PCK8063 | 698745 |
| PCK8068 | 698687 |
| PCK8085 | 715512 |

|  |  |
|---|---|
| COOPERS (.../...) | |
| PCK8091 | 715612 |
| PCK8095 | 698774 |
| PCK8103 | 698683 |
| PCK8104 | 698746 |
| PCK8111 | 715539 |
| PCK8164 | 715610 |
| PCK8198 | 715702 |
| PCK8214 | 715511 |
| PCK8216 | 715635 |
| PCK8219 | 698883 |
| PCK8226 | 715608 |
| PCK8227 | 715505 |
| PCK8229 | 698802 |
| PCK8230 | 698872 |
| PCK8249 | 715647 |
| PCK8250 | 715661 |
| PCK8253 | 715672 |
| PCK8255 | 715659 |
| PCK8260-2 | 715544 |
| PCK8262 | 698776 |
| PCK8263 | 715586 |
| PCK8264 | 715722 |
| PCK8278 | 715600 |
| CORTECO | |
| 21650107 | 698168 |
| 21651182 | 698165 |
| 21651183 | 698167 |
| 21651184 | 698166 |
| 21651185 | 698202 |
| 21651195 | 698772 |
| 21651195 | 715531 |
| 21651196 | 698169 |
| 21651196 | 698169 |
| 21651197 | 698170 |
| 21651198 | 698171 |
| 21651199 | 715684 |
| 21651292 | 698744 |
| 21651293 | 698488 |
| 21651293 | 698749 |
| 21651294 | 698778 |
| 21651295 | 698774 |
| 21651296 | 698535 |
| 21651296 | 698839 |

|  |  |
|---|---|
| CORTECO (.../...) | |
| 21651881 | 698470 |
| 21651881 | 698838 |
| 21651882 | 698246 |
| 21651887 | 698704 |
| 21651890 | 698164 |
| 21651891 | 698164 |
| 21651891 | 698235 |
| 21651893 | 698201 |
| 21651894 | 698198 |
| 21651895 | 698247 |
| 21651895 | 698696 |
| 21651896 | 698199 |
| 21651897 | 698246 |
| 21651897 | 715685 |
| 21651898 | 698163 |
| 21651899 | 698146 |
| 21651901 | 698197 |
| 21651911 | 698770 |
| 21651912 | 698159 |
| 21651912 | 698679 |
| 21651912 | 698885 |
| 21651914 | 715683 |
| 21651914 | 698684 |
| 21651915 | 698174 |
| 21651916 | 698173 |
| 21651917 | 698149 |
| 21651918 | 698172 |
| 21651920 | 698203 |
| 21651952 | 698197 |
| 21651953 | 698687 |
| 21651954 | 698688 |
| 21651955 | 698686 |
| 21651956 | 715578 |
| 21651956 | 698164 |
| 21651957 | 698682 |
| 21651958 | 698684 |
| 21651960 | 698696 |
| 21651961 | 698697 |
| 21651963 | 698746 |
| 21651964 | 715632 |
| 21651966 | 715675 |
| 21651966 | 698202 |

|  |  |
|---|---|
| CORTECO (.../...) | |
| 21651967 | 698716 |
| 21651968 | 698163 |
| 21651969 | 698489 |
| 21651970 | 698689 |
| 21651972 | 698196 |
| 21651974 | 698706 |
| 21651976 | 698840 |
| 21651979 | 698662 |
| 21651979 | 698874 |
| 21651980 | 698663 |
| 21651981 | 715645 |
| 21651982 | 698712 |
| 21651983 | 698255 |
| 21651984 | 698177 |
| 21651984 | 698279 |
| 21651986 | 698770 |
| 21651987 | 698794 |
| 21651991 | 698878 |
| 21651994 | 698858 |
| 21651995 | 698487 |
| 21652045 | 715577 |
| 21652308 | 698454 |
| 21652317 | 698771 |
| 21652335 | 698701 |
| 21652336 | 698750 |
| 21652336 | 698489 |
| 21652338 | 698860 |
| 21652338 | 715526 |
| 21652340 | 698859 |
| 21652341 | 698859 |
| 21652345 | 698869 |
| 21652346 | 698734 |
| 21652347 | 698707 |
| 21652348 | 698276 |
| 21652349 | 698512 |
| 21652350 | 698773 |
| 21652351 | 698769 |
| 21652352 | 698747 |
| 21652354 | 698695 |
| 21652355 | 715617 |
| 21652356 | 698685 |
| 21652357 | 698739 |

**Valeo****CORTECO (.../...)**

| | |
|----------|---------------|
| 21652357 | 698685 |
| 21652358 | 698700 |
| 21652359 | 715573 |
| 21652360 | 698762 |
| 21652361 | 698745 |
| 21652538 | 698692 |
| 21652539 | 698796 |
| 21652539 | 715563 |
| 21652540 | 698714 |
| 21652541 | 698748 |
| 21652542 | 698715 |
| 21652543 | 698680 |
| 21652544 | 698867 |
| 21652544 | 698535 |
| 21652546 | 698735 |
| 21652548 | 698664 |
| 21652550 | 698594 |
| 21652551 | 698681 |
| 21652552 | 698791 |
| 21652687 | 698290 |
| 21652687 | 715562 |
| 21652687 | 715568 |
| 21652688 | 698475 |
| 21652688 | 698475 |
| 21652689 | 698606 |
| 21652694 | 698751 |
| 21652709 | 698779 |
| 21652713 | 698683 |
| 21652714 | 698711 |
| 21652715 | 698710 |
| 21652812 | 715621 |
| 21652848 | 698856 |
| 21652849 | 698861 |
| 21652850 | 698724 |
| 21652851 | 698857 |
| 21652852 | 698862 |
| 21652853 | 698725 |
| 21652854 | 698865 |
| 21652855 | 715611 |
| 21652856 | 698738 |
| 21652856 | 715530 |
| 21652857 | 698694 |

**Valeo****CORTECO (.../...)**

| | |
|----------|---------------|
| 21652858 | 698693 |
| 21652859 | 715505 |
| 21652860 | 698891 |
| 21652860 | 698890 |
| 21652861 | 698743 |
| 21652863 | 698702 |
| 21652865 | 698741 |
| 21652867 | 715545 |
| 21652867 | 715548 |
| 21652868 | 715528 |
| 21652870 | 715549 |
| 21652872 | 698737 |
| 21652873 | 715565 |
| 21652874 | 698795 |
| 21652897 | 715572 |
| 21652898 | 698792 |
| 21652899 | 698691 |
| 21652900 | 698690 |
| 21652916 | 698776 |
| 21652985 | 698840 |
| 21652989 | 698886 |
| 21652990 | 715594 |
| 21652991 | 715504 |
| 21652992 | 698870 |
| 21652993 | 698893 |
| 21652994 | 698876 |
| 21652995 | 698877 |
| 21652996 | 715512 |
| 21653002 | 698797 |
| 21653008 | 698801 |
| 21653009 | 698872 |
| 21653011 | 698705 |
| 21653013 | 698802 |
| 21653013 | 715603 |
| 21653014 | 698774 |
| 21653015 | 698768 |
| 21653017 | 698879 |
| 21653020 | 715581 |
| 21653020 | 698768 |
| 21653023 | 698790 |
| 21653024 | 698800 |
| 21653025 | 698871 |

**Valeo****CORTECO (.../...)**

| | |
|----------|---------------|
| 21653026 | 698866 |
| 21653027 | 715686 |
| 21653028 | 698657 |
| 21653029 | 698777 |
| 21653029 | 698778 |
| 21653030 | 698838 |
| 21653031 | 698793 |
| 21653032 | 698731 |
| 21653033 | 715590 |
| 21653034 | 698882 |
| 21653035 | 698883 |
| 21653063 | 698863 |
| 21653064 | 698864 |
| 21653066 | 715501 |
| 21653067 | 715500 |
| 21653068 | 698749 |
| 21653069 | 715676 |
| 21653070 | 715568 |
| 21653071 | 698730 |
| 21653102 | 698884 |
| 21653114 | 715514 |
| 21653115 | 698723 |
| 21653140 | 698177 |
| 21653141 | 698540 |
| 21653142 | 698541 |
| 21653143 | 715507 |
| 21653144 | 715506 |
| 21653145 | 698870 |
| 21653146 | 715629 |
| 21653147 | 715558 |
| 21653148 | 698713 |
| 21653149 | 698713 |
| 26152355 | 698201 |
| 80000021 | 698709 |
| 80000021 | 698875 |
| 80000022 | 698469 |
| 80000027 | 715646 |
| 80000029 | 698819 |
| 80000029 | 698196 |
| 80000060 | 698817 |
| 80000061 | 715510 |
| 80000062 | 715511 |

|  | Valeo |
|---|--------------|
| CORTECO (.../...) | |
| 8000063 | 715502 |
| 8000064 | 715503 |
| 8000065 | 698775 |
| 8000066 | 715598 |
| 8000067 | 698873 |
| 8000068 | 715509 |
| 8000069 | 715571 |
| 8000070 | 698880 |
| 8000071 | 715508 |
| 8000072 | 715513 |
| 8000074 | 698753 |
| 8000077 | 715677 |
| 8000079 | 715670 |
| 8000080 | 698736 |
| 8000082 | 715534 |
| 8000083 | 715517 |
| 8000083 | 715591 |
| 8000084 | 715525 |
| 8000113 | 698708 |
| 8000114 | 715538 |
| 8000155 | 715535 |
| 8000156 | 715593 |
| 8000157 | 715516 |
| 8000158 | 698888 |
| 8000159 | 715527 |
| 8000160 | 715569 |
| 8000162 | 715542 |
| 8000163 | 715574 |
| 8000164 | 715551 |
| 8000165 | 715641 |
| 8000330 | 698868 |
| 8000345 | 715532 |
| 8000346 | 715533 |
| 8000360 | 715518 |
| 8000361 | 715519 |
| 8000373 | 698176 |
| 8000402 | 698888 |
| 8000403 | 698890 |
| 8000405 | 698892 |
| 8000406 | 698892 |
| 8000408 | 715648 |
| 8000409 | 698723 |
| 8000412 | 715687 |

|  | Valeo |
|---|--------------|
| CORTECO (.../...) | |
| 8000415 | 715670 |
| 8000418 | 698512 |
| 8000429 | 698680 |
| 8000431 | 715573 |
| 8000436 | 698279 |
| 8000440 | 715517 |
| 8000536 | 698175 |
| 8000538 | 715643 |
| 8000541 | 715552 |
| 8000546 | 715529 |
| 8000548 | 715522 |
| 8000602 | 715665 |
| 8000603 | 698886 |
| 8000604 | 715550 |
| 8000605 | 715550 |
| 8000606 | 715640 |
| 8000614 | 715601 |
| 8000615 | 715555 |
| 8000615 | 715554 |
| 8000616 | 715602 |
| 8000616 | 715601 |
| 8000617 | 715637 |
| 8000620 | 715540 |
| 8000621 | 698710 |
| 8000622 | 715540 |
| 8000628 | 715653 |
| 8000634 | 698859 |
| 8000636 | 715653 |
| 8000637 | 715615 |
| 8000643 | 715545 |
| 8000644 | 715523 |
| 8000647 | 715544 |
| 8000648 | 715546 |
| 8000649 | 715520 |
| 8000652 | 715521 |
| 8000654 | 715523 |
| 8000655 | 698895 |
| 8000657 | 698894 |
| 8000660 | 715556 |
| 8000662 | 715515 |
| 8000666 | 715556 |
| 8000667 | 715557 |
| 8000670 | 715539 |

|  | Valeo |
|---|--------------|
| CORTECO (.../...) | |
| 8000671 | 715682 |
| 8000676 | 715609 |
| 8000689 | 715657 |
| 8000712 | 715597 |
| 8000740 | 715585 |
| 8000741 | 715586 |
| 8000741 | 715585 |
| 8000742 | 698869 |
| 8000745 | 715619 |
| 8000760 | 698688 |
| 8000761 | 715645 |
| 8000764 | 715541 |
| 8000775 | 698817 |
| 8000776 | 698887 |
| 8000777 | 715553 |
| 8000779 | 715615 |
| 8000783 | 715526 |
| 8000784 | 715515 |
| 8000785 | 715564 |
| 8000786 | 715520 |
| 8000788 | 698175 |
| 8000802 | 715509 |
| 8000804 | 715526 |
| 8000807 | 715570 |
| 8000812 | 715590 |
| 8000813 | 715592 |
| 8000815 | 715636 |
| 8000816 | 715636 |
| 8000817 | 698160 |
| 8000824 | 715547 |
| 8000825 | 715688 |
| 8000839 | 715554 |
| 8000844 | 715600 |
| 8000847 | 715583 |
| 8000848 | 715584 |
| 8000848 | 715583 |
| 8000852 | 715591 |
| 8000853 | 715631 |
| 8000854 | 715630 |
| 8000865 | 715614 |
| 8000866 | 715614 |
| 8000869 | 715588 |
| 8000871 | 715596 |

**Valeo****CORTECO (.../...)**

| | |
|----------|--------|
| 80000874 | 715559 |
| 80000875 | 715559 |
| 80000877 | 715654 |
| 80000878 | 715654 |
| 80000879 | 715579 |
| 80000880 | 715580 |
| 80000911 | 715639 |
| 80000912 | 715639 |
| 80000915 | 715595 |
| 80001024 | 715561 |
| 80001027 | 715616 |
| 80001030 | 715607 |
| 80001031 | 715607 |
| 80001033 | 715536 |
| 80001035 | 715608 |
| 80001036 | 715644 |
| 80001041 | 715575 |
| 80001129 | 715661 |
| 80001130 | 715669 |
| 80001170 | 715513 |
| 80001171 | 715616 |
| 80001179 | 715681 |
| 80001185 | 715658 |
| 80001185 | 715658 |
| 80001186 | 715659 |
| 80001208 | 715663 |
| 80001211 | 715690 |
| 80001439 | 715624 |
| 80001447 | 715668 |
| 80001450 | 715672 |
| 80001456 | 715649 |
| 80001459 | 715635 |
| 80001460 | 715647 |

DELPHI



| | |
|-------------|--------|
| TSP0325001 | 698199 |
| TSP0325002 | 698174 |
| TSP0325003 | 698164 |
| TSP0325003C | 715578 |
| TSP0325004 | 698159 |
| TSP0325004 | 698885 |
| TSP0325004C | 698686 |
| TSP0325005 | 698171 |
| TSP0325006 | 698170 |



**Valeo****DELPHI (.../...)**



| | |
|-------------|--------|
| TSP0325007 | 698146 |
| TSP0325009 | 698197 |
| TSP0325009C | 698687 |
| TSP0325010 | 698198 |
| TSP0325011 | 698168 |
| TSP0325011 | 698779 |
| TSP0325011C | 698745 |
| TSP0325012 | 698201 |
| TSP0325012 | 715617 |
| TSP0325014 | 698688 |
| TSP0325015 | 698165 |
| TSP0325015C | 715632 |
| TSP0325016 | 698166 |
| TSP0325017 | 698746 |
| TSP0325017 | 698167 |
| TSP0325018 | 698235 |
| TSP0325019 | 698203 |
| TSP0325019C | 698748 |
| TSP0325020 | 698173 |
| TSP0325021 | 698149 |
| TSP0325021 | 698176 |
| TSP0325022 | 715653 |
| TSP0325023 | 698160 |
| TSP0325024 | 698163 |
| TSP0325026 | 698202 |
| TSP0325027C | 698716 |
| TSP0325028 | 698662 |
| TSP0325028C | 698709 |
| TSP0325029 | 698247 |
| TSP0325029C | 698696 |
| TSP0325031 | 698279 |
| TSP0325032 | 698819 |
| TSP0325033 | 698196 |
| TSP0325034 | 698255 |
| TSP0325034C | 715538 |
| TSP0325035 | 698177 |
| TSP0325036 | 698290 |
| TSP0325037 | 698276 |
| TSP0325038C | 698246 |
| TSP0325039 | 698682 |
| TSP0325040 | 698684 |
| TSP0325042 | 698858 |
| TSP0325043 | 698691 |

**Valeo****DELPHI (.../...)**

| | |
|-------------|--------|
| TSP0325044 | 698454 |
| TSP0325047 | 698772 |
| TSP0325047C | 715531 |
| TSP0325048 | 698487 |
| TSP0325048C | 698695 |
| TSP0325050 | 698753 |
| TSP0325050 | 715549 |
| TSP0325051 | 698663 |
| TSP0325051C | 698708 |
| TSP0325052 | 698860 |
| TSP0325053 | 698859 |
| TSP0325054 | 698865 |
| TSP0325055 | 715514 |
| TSP0325056 | 698723 |
| TSP0325058 | 698770 |
| TSP0325059 | 698869 |
| TSP0325060 | 715530 |
| TSP0325061 | 698475 |
| TSP0325061C | 698744 |
| TSP0325062 | 698488 |
| TSP0325062C | 698749 |
| TSP0325063 | 715633 |
| TSP0325065 | 698790 |
| TSP0325065 | 698791 |
| TSP0325072 | 698707 |
| TSP0325072C | 698707 |
| TSP0325074 | 698172 |
| TSP0325077 | 698840 |
| TSP0325079 | 698535 |
| TSP0325080 | 698774 |
| TSP0325082 | 698681 |
| TSP0325083 | 698700 |
| TSP0325083C | 698743 |
| TSP0325084 | 698512 |
| TSP0325085 | 698680 |
| TSP0325085C | 715612 |
| TSP0325086 | 698879 |
| TSP0325088 | 715512 |
| TSP0325092 | 715646 |
| TSP0325098 | 698712 |
| TSP0325101 | 698777 |
| TSP0325102 | 698773 |
| TSP0325105 | 698878 |

|  |  |
|---|---|
| DELPHI (.../...) | |
| TSP0325106 | 698769 |
| TSP0325107 | 698169 |
| TSP0325107C | 698697 |
| TSP0325108 | 698734 |
| TSP0325110C | 698747 |
| TSP0325111 | 698685 |
| TSP0325111C | 698739 |
| TSP0325112 | 698606 |
| TSP0325112C | 698683 |
| TSP0325113 | 698657 |
| TSP0325113 | 715629 |
| TSP0325114 | 698731 |
| TSP0325116 | 698692 |
| TSP0325119 | 698890 |
| TSP0325119 | 698891 |
| TSP0325122 | 698711 |
| TSP0325122 | 698877 |
| TSP0325123 | 698664 |
| TSP0325123C | 698714 |
| TSP0325124 | 698594 |
| TSP0325124C | 698715 |
| TSP0325128 | 698796 |
| TSP0325129 | 698771 |
| TSP0325139 | 698694 |
| TSP0325139C | 698693 |
| TSP0325140 | 698762 |
| TSP0325141 | 698735 |
| TSP0325146 | 715509 |
| TSP0325148 | 698795 |
| TSP0325149 | 715619 |
| TSP0325151 | 698794 |
| TSP0325152 | 698867 |
| TSP0325153 | 698868 |
| TSP0325154 | 698689 |
| TSP0325155 | 698489 |
| TSP0325155C | 698750 |
| TSP0325158 | 715577 |
| TSP0325159 | 698724 |
| TSP0325159C | 698725 |
| TSP0325161 | 698775 |
| TSP0325161C | 698776 |
| TSP0325162 | 698738 |
| TSP0325162C | 715558 |

|  |  |
|---|---|
| DELPHI (.../...) | |
| TSP0325163 | 698866 |
| TSP0325164 | 698882 |
| TSP0325164 | 715510 |
| TSP0325165 | 715594 |
| TSP0325166 | 698751 |
| TSP0325167 | 698799 |
| TSP0325167 | 698817 |
| TSP0325168 | 715598 |
| TSP0325171 | 698876 |
| TSP0325172 | 698737 |
| TSP0325174 | 698800 |
| TSP0325174C | 698801 |
| TSP0325175 | 715619 |
| TSP0325176 | 698870 |
| TSP0325176C | 715679 |
| TSP0325178 | 698753 |
| TSP0325178C | 698753 |
| TSP0325179 | 715529 |
| TSP0325180 | 715627 |
| TSP0325180C | 715628 |
| TSP0325181 | 715575 |
| TSP0325182 | 715524 |
| TSP0325183 | 698884 |
| TSP0325184 | 715502 |
| TSP0325184C | 715503 |
| TSP0325185 | 698802 |
| TSP0325186 | 715506 |
| TSP0325186C | 715506 |
| TSP0325187 | 715505 |
| TSP0325188 | 715500 |
| TSP0325189 | 698874 |
| TSP0325189C | 698875 |
| TSP0325190 | 715534 |
| TSP0325191 | 698871 |
| TSP0325193 | 715513 |
| TSP0325194 | 698730 |
| TSP0325194C | 715539 |
| TSP0325195 | 698736 |
| TSP0325195C | 698736 |
| TSP0325196 | 698777 |
| TSP0325196 | 698778 |
| TSP0325198 | 715508 |
| TSP0325199C | 715544 |

|  |  |
|---|---|
| DELPHI (.../...) | |
| TSP0325200 | 715643 |
| TSP0325201 | 715551 |
| TSP0325201C | 715680 |
| TSP0325202 | 698892 |
| TSP0325203 | 715522 |
| TSP0325204 | 715540 |
| TSP0325205 | 715553 |
| TSP0325205C | 715552 |
| TSP0325206 | 715515 |
| TSP0325207 | 715532 |
| TSP0325207C | 715533 |
| TSP0325208 | 698702 |
| TSP0325208C | 698741 |
| TSP0325209 | 715535 |
| TSP0325211 | 715517 |
| TSP0325212 | 698863 |
| TSP0325212C | 698864 |
| TSP0325213 | 698540 |
| TSP0325213C | 698541 |
| TSP0325214 | 715573 |
| TSP0325221 | 715596 |
| TSP0325222 | 715521 |
| TSP0325223 | 698888 |
| TSP0325224 | 715639 |
| TSP0325225 | 715518 |
| TSP0325225C | 715519 |
| TSP0325226 | 715597 |
| TSP0325226C | 715635 |
| TSP0325227 | 715559 |
| TSP0325227C | 715559 |
| TSP0325228 | 715631 |
| TSP0325229C | 715556 |
| TSP0325229C | 715557 |
| TSP0325231 | 715609 |
| TSP0325232 | 715619 |
| TSP0325232 | 715620 |
| TSP0325232C | 715550 |
| TSP0325238 | 715588 |
| TSP0325239 | 715579 |
| TSP0325239C | 715580 |
| TSP0325240 | 715581 |
| TSP0325240C | 698768 |
| TSP0325242 | 715587 |

|  | Valeo |
|---|--------------|
| DELPHI (.../...) | |
| TSP0325243 | 715648 |
| TSP0325244 | 715636 |
| TSP0325245 | 715613 |
| TSP0325245 | 715614 |
| TSP0325246 | 715554 |
| TSP0325246C | 715555 |
| TSP0325247 | 715590 |
| TSP0325249 | 715537 |
| TSP0325250 | 715592 |
| TSP0325252C | 715541 |
| TSP0325254 | 715595 |
| TSP0325255 | 715504 |
| TSP0325256 | 698895 |
| TSP0325257 | 715542 |
| TSP0325258 | 715600 |
| TSP0325259 | 715601 |
| TSP0325259C | 715602 |
| TSP0325260 | 715585 |
| TSP0325260 | 715586 |
| TSP0325262 | 715520 |
| TSP0325263 | 715654 |
| TSP0325264C | 698713 |
| TSP0325266 | 715608 |
| TSP0325269 | 715651 |
| TSP0325296 | 698710 |
| TSP0325296C | 698839 |
| TSP0325299 | 698886 |
| TSP0325300 | 715525 |
| TSP0325305 | 715511 |
| TSP0325305 | 715658 |
| TSP0325305C | 715659 |
| TSP0325310C | 715660 |
| TSP0325310C | 715661 |
| TSP0325311 | 715642 |
| TSP0325312 | 715644 |
| TSP0325313 | 715649 |
| TSP0325314C | 715607 |
| TSP0325315C | 715647 |
| TSP0325318 | 715616 |
| ECO | |
| 328 | 698745 |
| 405 | 698697 |
| 406 | 698744 |

|  | Valeo |
|---|--------------|
| ECO (.../...) | |
| 419 | 698708 |
| 420 | 698684 |
| 440 | 698748 |
| 446 | 698723 |
| 451 | 715619 |
| 456 | 698470 |
| 457 | 698857 |
| 458 | 698750 |
| 459 | 698246 |
| 473 | 698746 |
| 479 | 698693 |
| 480 | 698688 |
| 487 | 698791 |
| 488 | 698747 |
| 490 | 698714 |
| 491 | 698541 |
| 494 | 715612 |
| 496 | 698865 |
| 502 | 698687 |
| 508 | 698715 |
| 510 | 698749 |
| 511 | 698716 |
| 512 | 715512 |
| 520 | 698682 |
| 521 | 698683 |
| 524 | 698695 |
| 531 | 715617 |
| 532 | 698696 |
| 542 | 698739 |
| 550 | 698743 |
| 553 | 698741 |
| 555 | 698776 |
| 567 | 715628 |
| 568 | 698883 |
| 572 | 715507 |
| 573 | 698692 |
| 582 | 715509 |
| 585 | 698864 |
| 586 | 698802 |
| 588 | 698884 |
| 590 | 698872 |
| 591 | 698890 |
| 600 | 715501 |

|  | Valeo |
|---|--------------|
| ECO (.../...) | |
| 602 | 715503 |
| 603 | 715619 |
| 609 | 698877 |
| 610 | 698880 |
| 611 | 698801 |
| 614 | 698862 |
| 615 | 715508 |
| 642 | 715619 |
| 1300 | 698199 |
| 1314 | 698171 |
| 1317 | 698163 |
| 1318 | 698165 |
| 1319 | 698166 |
| 1328 | 698168 |
| 1328 | 698779 |
| 1400 | 698172 |
| 1401 | 698198 |
| 1405 | 698169 |
| 1406 | 698475 |
| 1414 | 698235 |
| 1415 | 698888 |
| 1419 | 698663 |
| 1421 | 698146 |
| 1422 | 698196 |
| 1423 | 715516 |
| 1424 | 715517 |
| 1426 | 698795 |
| 1428 | 698290 |
| 1429 | 698177 |
| 1430 | 698279 |
| 1434 | 698707 |
| 1436 | 698202 |
| 1438 | 698173 |
| 1440 | 698203 |
| 1451 | 698796 |
| 1456 | 698838 |
| 1457 | 698856 |
| 1458 | 698489 |
| 1467 | 698840 |
| 1473 | 698167 |
| 1474 | 698878 |
| 1479 | 698694 |
| 1482 | 715525 |

|  | Valeo |
|---|--------------|
| ECO (.../...) | |
| 1483 | 715530 |
| 1484 | 698794 |
| 1487 | 698790 |
| 1490 | 698664 |
| 1491 | 698540 |
| 1492 | 698657 |
| 1494 | 698680 |
| 1498 | 698690 |
| 1499 | 698691 |
| 1500 | 698454 |
| 1501 | 698535 |
| 1501 | 698867 |
| 1502 | 698197 |
| 1504 | 698276 |
| 1506 | 698512 |
| 1508 | 698594 |
| 1510 | 698488 |
| 1512 | 698771 |
| 1521 | 698606 |
| 1522 | 698738 |
| 1524 | 698487 |
| 1529 | 698149 |
| 1531 | 698201 |
| 1532 | 698247 |
| 1540 | 698858 |
| 1542 | 698685 |
| 1543 | 698894 |
| 1544 | 698731 |
| 1547 | 715522 |
| 1550 | 698700 |
| 1552 | 715524 |
| 1553 | 698702 |
| 1555 | 698775 |
| 1558 | 698770 |
| 1564 | 715527 |
| 1566 | 698892 |
| 1567 | 715627 |
| 1568 | 698882 |
| 1568 | 715510 |
| 1572 | 715506 |
| 1579 | 715521 |
| 1585 | 698863 |

|  | Valeo |
|---|--------------|
| ECO (.../...) | |
| 1590 | 698871 |
| 1591 | 698891 |
| 1592 | 698866 |
| 1593 | 715526 |
| 1598 | 698895 |
| 1599 | 698868 |
| 1600 | 715500 |
| 1609 | 698876 |
| 1610 | 698879 |
| 1611 | 698800 |
| 1614 | 698861 |
| 1625 | 698174 |
| 1632 | 698769 |
| 1642 | 698681 |
| 1644 | 715624 |
| 1652 | 698734 |
| 1652 | 698869 |
| 1323/1 | 698170 |
| 1402/1 | 698164 |
| 1411/1 | 698159 |
| 1411/1 | 698679 |
| 1411/1 | 698885 |
| 1418/1 | 698662 |
| 1418/1 | 698874 |
| 1472/1 | 698711 |
| 1486/1 | 715514 |
| 1509/1 | 698255 |
| 1514/1 | 698469 |
| 411/1 | 698686 |
| 418/1 | 698709 |
| 418/1 | 698875 |
| 472/1 | 698710 |
| FIAAM | |
| PC8001 | 698160 |
| PC8002 | 698165 |
| PC8003 | 698146 |
| PC8004 | 698164 |
| PC8005 | 698159 |
| PC8006 | 698168 |
| PC8007 | 698166 |
| PC8008 | 698199 |
| PC8010 | 698167 |
| PC8011 | 698197 |

|  | Valeo |
|---|--------------|
| FIAAM (.../...) | |
| PC8012 | 698201 |
| PC8012 | 715617 |
| PC8013 | 698174 |
| PC8014 | 698198 |
| PC8015 | 698171 |
| PC8016 | 698169 |
| PC8017 | 698196 |
| PC8018 | 698235 |
| PC8020 | 698203 |
| PC8022 | 698173 |
| PC8022 | 698594 |
| PC8023 | 698149 |
| PC8024 | 698247 |
| PC8028 | 698202 |
| PC8030 | 698276 |
| PC8031 | 698170 |
| PC8032 | 698606 |
| PC8035 | 698475 |
| PC8038 | 698177 |
| PC8038 | 698279 |
| PC8041 | 698290 |
| PC8043 | 698487 |
| PC8044 | 698454 |
| PC8046 | 698663 |
| PC8046 | 698708 |
| PC8047 | 698662 |
| PC8047 | 698874 |
| PC8049 | 698731 |
| PC8050 | 698770 |
| PC8051 | 698858 |
| PC8052 | 698712 |
| PC8053 | 698489 |
| PC8056 | 715530 |
| PC8058 | 698840 |
| PC8059 | 698255 |
| PC8060 | 698488 |
| PC8077 | 698685 |
| PC8079 | 698773 |
| PC8080 | 698869 |
| PC8081 | 698707 |
| PC8083 | 698734 |
| PC8084 | 698715 |

**Valeo****FIAAM (.../...)**

| | |
|----------------|--------|
| PC8085 | 698771 |
| PC8088 | 698664 |
| PC8091 | 698680 |
| PC8093 | 698839 |
| PC8094 | 698163 |
| PC8096 | 715619 |
| PC8097 | 698711 |
| PC8098 | 698762 |
| PC8102 | 698149 |
| PC8110 | 698540 |
| PC8112 | 698878 |
| PC8129 | 698879 |
| PC8139 | 715627 |
| PC8143-2 | 698735 |
| PC8144 | 698796 |
| PC8161 | 715510 |
| PC8233 | 698175 |
| PCK8036 | 698688 |
| PCK8043 | 698695 |
| PCK8045 | 698686 |
| PCK8045 | 698716 |
| PCK8053 | 698750 |
| PCK8054 | 698246 |
| PCK8062 | 698682 |
| PCK8065 | 698697 |
| PCK8066 | 698696 |
| PCK8067 | 715675 |
| PCK8068 | 698687 |
| PCK8072 | 698686 |
| PCK8073 | 698746 |
| PCK8078 | 698470 |
| PCK8090 | 698747 |
| PCK8092 | 698739 |
| PCK8095 | 698774 |
| PCK8099 | 698745 |
| PCK8100 | 698692 |
| PCK8104 | 698746 |
| PCK8109 | 698714 |
| PCK8122 | 715617 |
| PCK8204-2 | 715555 |
| PCK8240 | 715571 |
| FILTRON | |
| K 1000 | 698165 |

**Valeo****FILTRON (.../...)**

| | |
|-----------|--------|
| K 1001 | 715645 |
| K 1001A | 698746 |
| K 1002 | 698166 |
| K 1004 | 698164 |
| K 1005 | 698160 |
| K 1006 | 698885 |
| K 1006A | 698686 |
| K 1007 | 698146 |
| K 1008 | 698168 |
| K 1009 | 698202 |
| K 1009A | 715675 |
| K 1010 | 698201 |
| K 1011 | 698860 |
| K 1014 | 698662 |
| K 1014A | 698709 |
| K 1014A | 698875 |
| K 1015 | 698171 |
| K 1016 | 698169 |
| K 1016A | 698697 |
| K 1017 | 698819 |
| K 1018 | 698235 |
| K 1020 | 698203 |
| K 1020A | 698748 |
| K 1022 | 698173 |
| K 1023 | 698149 |
| K 1024 | 698247 |
| K 1024A | 698696 |
| K 1030 | 698276 |
| K 1031 | 698170 |
| K 1032A | 698682 |
| K 1032A | 698684 |
| K 1033 | 698174 |
| K 1034 | 698198 |
| K 1035 | 698197 |
| K 1035A | 698687 |
| K 1037 | 698794 |
| K 1038 | 698691 |
| K 1039 | 698704 |
| K 1040-2x | 698290 |
| K 1044-2x | 698712 |
| K 1047A | 698716 |
| K 1051 | 698279 |

**Valeo****FILTRON (.../...)**

| | |
|------------|--------|
| K 1052 | 698255 |
| K 1053-2x | 715531 |
| K 1054 | 698487 |
| K 1054A | 698695 |
| K 1055 | 698663 |
| K 1056 | 698858 |
| K 1057 | 715633 |
| K 1058 | 698878 |
| K 1059 | 715653 |
| K 1060 | 698734 |
| K 1062-2x | 715530 |
| K 1064 | 715514 |
| K 1065 | 698475 |
| K 1065A | 698744 |
| K 1066 | 698488 |
| K 1067 | 698177 |
| K 1068 | 698163 |
| K 1069-2x | 698790 |
| K 1069A-2x | 698791 |
| K 1071 | 715646 |
| K 1072-2x | 698469 |
| K 1073A-2x | 698470 |
| K 1075A-2x | 698246 |
| K 1076A | 698454 |
| K 1077 | 698172 |
| K 1078 | 698606 |
| K 1078A | 698683 |
| K 1079 | 698685 |
| K 1079A | 698739 |
| K 1081 | 698711 |
| K 1081A | 698710 |
| K 1082 | 698196 |
| K 1083 | 698796 |
| K 1087 | 698869 |
| K 1088 | 698840 |
| K 1089 | 698594 |
| K 1089A | 698715 |
| K 1090 | 698773 |
| K 1093 | 698664 |
| K 1093A | 698714 |
| K 1095 | 698176 |
| K 1096 | 698707 |

|  | Valeo |
|---|--------------|
| FILTRON (.../...) | |
| K 1097 | 698512 |
| K 1101 | 698867 |
| K 1102 | 698680 |
| K 1103A | 698692 |
| K 1105A-2x | 698747 |
| K 1106 | 698700 |
| K 1106A | 698743 |
| K 1107 | 698731 |
| K 1108 | 715577 |
| K 1109-2x | 715575 |
| K 1110 | 698694 |
| K 1110A | 698693 |
| K 1111 | 698800 |
| K 1111A | 698801 |
| K 1112-2x | 698890 |
| K 1112-2x | 698891 |
| K 1113 | 698762 |
| K 1115 | 698769 |
| K 1115A | 715676 |
| K 1116A | 698688 |
| K 1117 | 698770 |
| K 1118A | 698792 |
| K 1119 | 698724 |
| K 1119A | 698725 |
| K 1121 | 715513 |
| K 1122 | 698866 |
| K 1123 | 698795 |
| K 1125 | 698540 |
| K 1125A | 698541 |
| K 1126 | 698771 |
| K 1126A | 715512 |
| K 1127 | 698657 |
| K 1128 | 698738 |
| K 1128A | 715558 |
| K 1130 | 698730 |
| K 1131 | 715562 |
| K 1131A | 698737 |
| K 1134-2x | 715572 |
| K 1136 | 698489 |
| K 1136A | 698750 |
| K 1137A | 698713 |
| K 1138 | 698876 |
| K 1138A | 698877 |

|  | Valeo |
|---|--------------|
| FILTRON (.../...) | |
| K 1140 | 698888 |
| K 1143-2x | 715598 |
| K 1145 | 698879 |
| K 1145A | 698880 |
| K 1146 | 698702 |
| K 1146A | 698741 |
| K 1147A | 698884 |
| K 1148 | 698779 |
| K 1148A | 698745 |
| K 1149 | 715517 |
| K 1150 | 715510 |
| K 1150 | 715627 |
| K 1150A | 715511 |
| K 1151 | 698175 |
| K 1152 | 698753 |
| K 1154 | 698882 |
| K 1154A | 698883 |
| K 1155 | 715581 |
| K 1155A | 698768 |
| K 1157 | 715573 |
| K 1159A | 698723 |
| K 1160-2x | 698863 |
| K 1160A-2x | 698864 |
| K 1161 | 698870 |
| K 1162-2x | 715500 |
| K 1162A-2x | 715501 |
| K 1163 | 698799 |
| K 1164 | 698886 |
| K 1165-2x | 698856 |
| K 1165A-2x | 698857 |
| K 1166 | 715526 |
| K 1167 | 698736 |
| K 1168A | 698865 |
| K 1169 | 715502 |
| K 1169A | 715503 |
| K 1172 | 715552 |
| K 1173 | 698887 |
| K 1174 | 715549 |
| K 1175 | 715540 |
| K 1176 | 698690 |
| K 1177 | 715565 |
| K 1178 | 715535 |
| K 1179 | 715557 |

|  | Valeo |
|---|--------------|
| FILTRON (.../...) | |
| K 1179A-2x | 715556 |
| K 1181 | 715551 |
| K 1182-2x | 715525 |
| K 1183 | 698681 |
| K 1187 | 698868 |
| K 1188 | 698871 |
| K 1189 | 715532 |
| K 1198-2x | 698735 |
| K 1200 A-2x | 715544 |
| K 1201A-2x | 715643 |
| K 1202A | 715507 |
| K 1202A | 715506 |
| K 1203-2x | 715522 |
| K 1204A | 698774 |
| K 1205A | 715508 |
| K 1207 | 715515 |
| K 1208-2x | 715523 |
| K 1210 | 715550 |
| K 1212-2x | 698892 |
| K 1215 | 715688 |
| K 1216A | 698802 |
| K 1218 | 698817 |
| K 1220A-2x | 698772 |
| K 1221A-2x | 698740 |
| K 1222A-2x | 698742 |
| K 1228 | 715616 |
| K 1232 | 715521 |
| K 1240A | 715546 |
| K 1241 | 715631 |
| K 1248 | 715649 |
| K 1251 | 715660 |
| K 1255 | 715559 |
| K 1265A | 698776 |
| K 1287 | 715524 |
| K 1296A | 715519 |
| FRAM | |
| CF10025 | 698866 |
| CF10059 | 715510 |
| CF10062 | 698868 |
| CF10067 | 698736 |
| CF10073 | 698886 |
| CF10080 | 715515 |
| CF10087 | 698817 |

|  | Valeo |
|---|---------------|
| FRAM (.../...) | |
| CF10129 | 715687 |
| CF10200 | 715532 |
| CF10204-2 | 715556 |
| CF10210 | 715521 |
| CF10218-2 | 698892 |
| CF10245-2 | 715525 |
| CF10282 | 715552 |
| CF10284 | 715689 |
| CF10285 | 715550 |
| CF10322 | 715550 |
| CF10329 | 715517 |
| CF10381 | 715541 |
| CF10411 | 715540 |
| CF10413 | 715616 |
| CF10420 | 715636 |
| CF10431 | 715631 |
| CF10436 | 715601 |
| CF10442 | 715597 |
| CF10450 | 715552 |
| CF10457 | 715579 |
| CF10471 | 715638 |
| CF10511-2 | 715642 |
| CF10526 | 715526 |
| CF10528 | 715724 |
| CF10534-2 | 715649 |
| CF10536-2 | 715554 |
| CF10597 | 715595 |
| CF10621 | 698871 |
| CF10627 | 715524 |
| CF10659 | 715660 |
| CF10763 | 715542 |
| CF10774 | 715658 |
| CF10776 | 715691 |
| CF10823 | 715694 |
| CF10917 | 715559 |
| CF10933-2 | 715662 |
| CF11119 | 715721 |
| CF11152 | 715705 |
| CF11166 | 715654 |
| CF11243 | 715706 |
| CF11247-2 | 715523 |
| CF5474 | 698160 |
| CF5475 | 698165 |

|  | Valeo |
|---|---------------|
| FRAM (.../...) | |
| CF5551 | 698146 |
| CF5662 | 698164 |
| CF5663 | 698159 |
| CF5663 | 698160 |
| CF5664 | 698168 |
| CF5664 | 698779 |
| CF5665 | 698166 |
| CF5816 | 698167 |
| CF5816 | 698746 |
| CF5817 | 698201 |
| CF5817 | 715617 |
| CF5817 | 698201 |
| CF5818 | 698198 |
| CF5819 | 698197 |
| CF5823 | 698174 |
| CF5824 | 698684 |
| CF5841 | 698199 |
| CF5842 | 698169 |
| CF5846 | 698203 |
| CF5848 | 698173 |
| CF5848 | 698594 |
| CF5848 | 698173 |
| CF5849 | 698149 |
| CF5850 | 698247 |
| CF5863 | 698202 |
| CF5864 | 698235 |
| CF5893 | 698276 |
| CF5935 | 698170 |
| CF5972 | 715531 |
| CF8103 | 698171 |
| CF8714 | 698770 |
| CF8717 | 698777 |
| CF8719 | 715598 |
| CF8750 | 698731 |
| CF8777 | 698475 |
| CF8777 | 698744 |
| CF8778 | 698723 |
| CF8799 | 698177 |
| CF8799 | 698279 |
| CF8831 | 698487 |
| CF8832 | 698290 |
| CF8838 | 698255 |
| CF8867 | 698663 |

|  | Valeo |
|---|---------------|
| FRAM (.../...) | |
| CF8867 | 698708 |
| CF8867 | 698663 |
| CF8868 | 698662 |
| CF8868 | 698874 |
| CF8868 | 698662 |
| CF8890 | 698858 |
| CF8912 | 698246 |
| CF8913 | 698489 |
| CF8913 | 698750 |
| CF8914 | 698712 |
| CF8948 | 715530 |
| CF8989 | 698691 |
| CF9051 | 698840 |
| CF9071 | 698488 |
| CF9077 | 698454 |
| CF9293 | 698512 |
| CF9294 | 698657 |
| CF9323 | 698685 |
| CF9335 | 698773 |
| CF9336 | 698769 |
| CF9337 | 698707 |
| CF9338 | 698196 |
| CF9338 | 698869 |
| CF9338 | 698819 |
| CF9363 | 698734 |
| CF9364 | 698715 |
| CF9364 | 698594 |
| CF9383 | 715577 |
| CF9394 | 698859 |
| CF9395 | 698860 |
| CF9395 | 715526 |
| CF9396 | 698771 |
| CF9398 | 698664 |
| CF9399 | 715573 |
| CF9406 | 698680 |
| CF9408 | 698839 |
| CF9408 | 698867 |
| CF9414 | 698163 |
| CF9442 | 698730 |
| CF9466 | 698681 |
| CF9466 | 715619 |
| CF9466 | 698681 |
| CF9485 | 698762 |

|  | Valeo |
|---|---------------|
| FRAM (.../...) | |
| CF9495 | 698710 |
| CF9495 | 698711 |
| CF9546 | 698176 |
| CF9562 | 698540 |
| CF9562 | 698541 |
| CF9579 | 698794 |
| CF9586 | 698738 |
| CF9594 | 698724 |
| CF9594 | 715585 |
| CF9594 | 698725 |
| CF9595 | 698878 |
| CF9640 | 698879 |
| CF9645 | 698606 |
| CF9659 | 715565 |
| CF9666 | 698694 |
| CF9686 | 698795 |
| CF9691 | 698753 |
| CF9714 | 715645 |
| CF9724 | 715514 |
| CF9731 | 698689 |
| CF9740 | 715572 |
| CF9742 | 715633 |
| CF9756 | 698888 |
| CF9761 | 698799 |
| CF9787 | 715627 |
| CF9787 | 698882 |
| CF9818 | 698175 |
| CF9819-2 | 698735 |
| CF9827 | 715562 |
| CF9832-2 | 715536 |
| CF9846 | 698796 |
| CF9880 | 715688 |
| CF9881 | 715581 |
| CF9881 | 698768 |
| CF9882 | 715631 |
| CF9904 | 698876 |
| CF9905 | 698700 |
| CF9920 | 715570 |
| CF9922 | 698800 |
| CF9934 | 715513 |
| CFA10055 | 715506 |
| CFA10055 | 715507 |

|  | Valeo |
|---|---------------|
| FRAM (.../...) | |
| CFA10067 | 715610 |
| CFA10103-2 | 698864 |
| CFA10199 | 715533 |
| CFA10205-2 | 715557 |
| CFA10206 | 715503 |
| CFA10209-2 | 715501 |
| CFA10307 | 715558 |
| CFA10365 | 715553 |
| CFA10366 | 715613 |
| CFA10366 | 715614 |
| CFA10417 | 715519 |
| CFA10419-2 | 715554 |
| CFA10435 | 715702 |
| CFA10436 | 715601 |
| CFA10458 | 715580 |
| CFA10474-2 | 715607 |
| CFA10527 | 715511 |
| CFA10529 | 715635 |
| CFA10582 | 698802 |
| CFA10584 | 698883 |
| CFA10612 | 715608 |
| CFA10613 | 715505 |
| CFA10621 | 698872 |
| CFA10657 | 715647 |
| CFA10761 | 715672 |
| CFA10773 | 715661 |
| CFA10775 | 715659 |
| CFA10828-2 | 715544 |
| CFA10830 | 698776 |
| CFA10831 | 715586 |
| CFA10934 | 715600 |
| CFA11119 | 715722 |
| CFA5551 | 715677 |
| CFA5846 | 698748 |
| CFA6404 | 698747 |
| CFA6405 | 698739 |
| CFA8046 | 698745 |
| CFA8788 | 698688 |
| CFA8831 | 698695 |
| CFA8838 | 715538 |
| CFA8869 | 698716 |
| CFA8874 | 698746 |

|  | Valeo |
|---|---------------|
| FRAM (.../...) | |
| CFA8875 | 715632 |
| CFA8876 | 698682 |
| CFA8877 | 698697 |
| CFA8878 | 698696 |
| CFA8879 | 715675 |
| CFA8882 | 715578 |
| CFA8893 | 698686 |
| CFA8894 | 698687 |
| CFA8912 | 698246 |
| CFA8913 | 698750 |
| CFA9071 | 698749 |
| CFA9322 | 698470 |
| CFA9364 | 698715 |
| CFA9396 | 715512 |
| CFA9404 | 698739 |
| CFA9405 | 698747 |
| CFA9406 | 715612 |
| CFA9408 | 698839 |
| CFA9442 | 715539 |
| CFA9445 | 698774 |
| CFA9495 | 698710 |
| CFA9533 | 698692 |
| CFA9534 | 698745 |
| CFA9548 | 698683 |
| CFA9562 | 698541 |
| CFA9587 | 698714 |
| CFA9594 | 698725 |
| CFA9623 | 715617 |
| CFA9665 | 698870 |
| CFA9666 | 698693 |
| CFA9785 | 698741 |
| CFA9788-2 | 698740 |
| CFA9825-2 | 698742 |
| CFA9827 | 698737 |
| CFA9909 | 715571 |
| CFA9920 | 698884 |
| CFA9921 | 698801 |
| CFA9930 | 698751 |
| CFA9931 | 698512 |
| HENGST | |
| E1901LJ | 698762 |
| E1903LJ | 698694 |
| E1906LJ | 698735 |

**Valeo****HENGST (.../...)**

| | |
|---------|--------|
| E1907LC | 698883 |
| E1907LJ | 698882 |
| E1909LC | 698864 |
| E1909LJ | 698863 |
| E190LJ | 698762 |
| E1911LC | 698174 |
| E1912LC | 698778 |
| E1916LC | 715512 |
| E1918LC | 715507 |
| E1918LJ | 715506 |
| E1919LC | 715621 |
| E1925LJ | 698737 |
| E1990LJ | 715510 |
| E1997LJ | 715618 |
| E2915LC | 715619 |
| E2915LJ | 715619 |
| E2945LJ | 715620 |
| E900LC | 698686 |
| E900LC | 698716 |
| E900LJ | 698160 |
| E900LJ | 698885 |
| E900LJ | 698159 |
| E901LJ | 698165 |
| E902LJ | 698166 |
| E903LC | 698746 |
| E903LJ | 698167 |
| E904LJ | 698202 |
| E905LJ | 698164 |
| E907LJ | 698168 |
| E908LC | 715617 |
| E908LJ | 698201 |
| E908LJ | 715617 |
| E909LJ | 698712 |
| E910LC | 698709 |
| E910LJ | 698662 |
| E910LJ | 698874 |
| E911LC | 698663 |
| E911LC | 698708 |
| E912LJ | 698840 |
| E913LC | 698744 |
| E913LJ | 698745 |
| E914LC | 698697 |

**Valeo****HENGST (.../...)**



| | |
|--------|--------|
| E914LJ | 698169 |
| E915LC | 698684 |
| E916LC | 715512 |
| E916LJ | 698290 |
| E917LJ | 698878 |
| E918LC | 715507 |
| E918LJ | 715506 |
| E919LC | 698696 |
| E919LJ | 698247 |
| E920LJ | 698770 |
| E921LJ | 698163 |
| E934LJ | 698197 |
| E936LC | 698682 |
| E936LJ | 698606 |
| E939LJ | 698171 |
| E940LJ | 698146 |
| E941LC | 698695 |
| E941LJ | 698487 |
| E943LJ | 698197 |
| E951LJ | 698203 |
| E952LJ | 698173 |
| E953LJ | 698858 |
| E955LC | 698683 |
| E955LJ | 698683 |
| E957LJ | 698704 |
| E959LJ | 698170 |
| E960LC | 698246 |
| E961LC | 698739 |
| E961LJ | 698685 |
| E962LJ | 698255 |
| E964LC | 698774 |
| E965LJ | 698149 |
| E967LJ | 698177 |
| E970LC | 698743 |
| E970LJ | 698700 |
| E971LJ | 698488 |
| E972LC | 698710 |
| E972LJ | 698711 |
| E973LJ | 698199 |
| E977LC | 698750 |
| E977LJ | 698489 |
| E978LJ | 715612 |



**Valeo****HENGST (.../...)**



| | |
|--------|--------|
| E979LJ | 698279 |
| E983LC | 698740 |
| E989LC | 698741 |
| E989LJ | 698702 |
| E990LC | 698541 |
| E990LJ | 698540 |
| E994LC | 698725 |
| E994LJ | 698724 |
| E997LC | 698715 |

KNECHT/MAHLE

| | |
|---------|--------|
| LA9 | 698235 |
| LA100 | 698196 |
| LA100 | 698869 |
| LA102 | 698489 |
| LA107 | 698769 |
| LA108 | 698276 |
| LA108 | 698279 |
| LA109 | 698681 |
| LA11 | 698165 |
| LA117 | 698711 |
| LA118 | 698762 |
| LA119 | 698734 |
| LA120 | 698685 |
| LA121 | 715577 |
| LA122 | 698735 |
| LA123 | 698858 |
| LA125 | 715599 |
| LA126 | 698689 |
| LA127 | 698540 |
| LA129 | 698700 |
| LA129/1 | 698701 |
| LA130 | 698707 |
| LA131 | 715619 |
| LA131 | 698796 |
| LA134 | 698512 |
| LA135 | 698731 |
| LA136 | 698594 |
| LA137 | 715645 |
| LA138 | 698664 |
| LA143 | 698773 |
| LA144 | 698535 |
| LA144 | 698867 |
| LA153 | 698680 |

|  |  |
|---|---|
| KNECHT/MAHLE (.../...) | |
| LA155 | 698886 |
| LA156 | 698702 |
| LA157 | 715619 |
| LA157 | 698795 |
| LA158 | 698870 |
| LA167 | 698738 |
| LA168/S | 715594 |
| LA169 | 698694 |
| LA171 | 698724 |
| LA172 | 715593 |
| LA175 | 698730 |
| LA177 | 698170 |
| LA180 | 715534 |
| LA181 | 698800 |
| LA182 | 715581 |
| LA183 | 698893 |
| LA184 | 698657 |
| LA189 | 698876 |
| LA191/S | 715556 |
| LA195/S | 715525 |
| LA196 | 715562 |
| LA197 | 698863 |
| LA197/S | 698863 |
| LA199 | 715542 |
| LA21 | 698166 |
| LA216 | 698868 |
| LA220 | 715627 |
| LA220 | 698882 |
| LA221/S | 715583 |
| LA227 | 698736 |
| LA229 | 698871 |
| LA23 | 698173 |
| LA230 | 698753 |
| LA234 | 698861 |
| LA235/S | 698894 |
| LA235/S | 715574 |
| LA237 | 698878 |
| LA239 | 715500 |
| LA241 | 698866 |
| LA242 | 698779 |
| LA243 | 698879 |
| LA248 | 715502 |
| LA25 | 698168 |



|  |  |
|---|---|
| KNECHT/MAHLE (.../...) | |
| LA265 | 715573 |
| LA269 | 715565 |
| LA27 | 698712 |
| LA280 | 715518 |
| LA282 | 715653 |
| LA287 | 698704 |
| LA288 | 715598 |
| LA289 | 715520 |
| LA291 | 698859 |
| LA296/S | 715548 |
| LA298 | 698895 |
| LA301 | 715521 |
| LA304 | 715515 |
| LA306 | 715532 |
| LA306 | 715552 |
| LA307 | 715601 |
| LA31 | 698159 |
| LA31 | 698160 |
| LA31 | 698885 |
| LA32/2 | 698203 |
| LA32/3 | 698203 |
| LA33 | 698149 |
| LA34 | 698174 |
| LA343 | 715541 |
| LA344 | 715540 |
| LA346/S | 698892 |
| LA347 | 698888 |
| LA348 | 715689 |
| LA349/S | 715527 |
| LA35 | 698198 |
| LA356/S | 715523 |
| LA36 | 698167 |
| LA360 | 698817 |
| LA361 | 715535 |
| LA362 | 715526 |
| LA365/S | 715522 |
| LA366/S | 715545 |
| LA368 | 715587 |
| LA37 | 698169 |
| LA37/1 | 715631 |
| LA371 | 698869 |
| LA376 | 715688 |
| LA377 | 715536 |



|  |  |
|---|---|
| KNECHT/MAHLE (.../...) | |
| LA38 | 715646 |
| LA381 | 698799 |
| LA382 | 715513 |
| LA384 | 715528 |
| LA385 | 715585 |
| LA387 | 715597 |
| LA39 | 698176 |
| LA391/S | 715699 |
| LA392/S | 715624 |
| LA394/S | 715569 |
| LA395 | 715550 |
| LA395 | 715620 |
| LA396 | 715559 |
| LA40 | 698177 |
| LA400 | 715656 |
| LA401 | 715591 |
| LA404 | 715549 |
| LA408 | 715609 |
| LA41 | 698175 |
| LA411 | 715636 |
| LA42/1 | 715654 |
| LA422 | 698690 |
| LA422 | 715615 |
| LA428/S | 715554 |
| LA439 | 715595 |
| LA44 | 698163 |
| LA441 | 715596 |
| LA441 | 715638 |
| LA444/S | 715639 |
| LA447 | 715592 |
| LA449 | 715644 |
| LA45 | 698164 |
| LA450/S | 715576 |
| LA451 | 715547 |
| LA452 | 715651 |
| LA456 | 715626 |
| LA457 | 715616 |
| LA46 | 698606 |
| LA461 | 715625 |
| LA462 | 715692 |
| LA463 | 715660 |
| LA468/S | 715649 |
| LA469 | 715667 |



|  Valeo | |
|--|--------|
| KNECHT/MAHLE (.../...) | |
| LA47/S | 715531 |
| LA471 | 715524 |
| LA472 | 715658 |
| LA475 | 715663 |
| LA476 | 698860 |
| LA48 | 715633 |
| LA480 | 715708 |
| LA483/S | 715642 |
| LA484 | 715516 |
| LA49 | 698202 |
| LA495 | 715662 |
| LA506 | 715514 |
| LA51/S | 698790 |
| LA52 | 698247 |
| LA531 | 715691 |
| LA54 | 698771 |
| LA54/1 | 715687 |
| LA56 | 698197 |
| LA57 | 698488 |
| LA586 | 715694 |
| LA60 | 698279 |
| LA624 | 715588 |
| LA65 | 698794 |
| LA74 | 698663 |
| LA75 | 698662 |
| LA75 | 698874 |
| LA76/S | 698290 |
| LA77 | 715617 |
| LA77 | 698201 |
| LA78 | 698487 |
| LA79 | 698770 |
| LA8 | 698146 |
| LA8 | 698657 |
| LA80 | 698171 |
| LA81 | 698475 |
| LA83 | 698840 |
| LA84 | 698819 |
| LA87 | 698255 |
| LA9 | 698235 |
| LA95 | 715668 |
| LA97 | 698454 |
| LA98 | 698777 |
| LAG113/S | 698890 |



|  Valeo | |
|--|--------|
| KNECHT/MAHLE (.../...) | |
| LAG113/S | 698891 |
| LAK102 | 698750 |
| LAK107 | 715676 |
| LAK11 | 715632 |
| LAK117 | 698710 |
| LAK120 | 698739 |
| LAK122 | 698864 |
| LAK124 | 698839 |
| LAK127 | 698541 |
| LAK129 | 698743 |
| LAK129/1 | 698743 |
| LAK131 | 715619 |
| LAK136 | 698715 |
| LAK138 | 698714 |
| LAK141 | 698747 |
| LAK142 | 698692 |
| LAK145 | 698751 |
| LAK153 | 715612 |
| LAK156 | 698741 |
| LAK158 | 715679 |
| LAK167 | 715558 |
| LAK169 | 698693 |
| LAK171 | 698725 |
| LAK173 | 698857 |
| LAK175 | 715539 |
| LAK176 | 698792 |
| LAK181 | 698801 |
| LAK181/1 | 715665 |
| LAK182 | 698768 |
| LAK184 | 715629 |
| LAK189 | 698877 |
| LAK191/S | 715557 |
| LAK196 | 698737 |
| LAK220 | 715628 |
| LAK220 | 698883 |
| LAK221/S | 715584 |
| LAK225/S | 698793 |
| LAK229 | 698872 |
| LAK232 | 698884 |
| LAK234 | 698862 |
| LAK239 | 715501 |
| LAK242 | 698745 |
| LAK243 | 698880 |



|  Valeo | |
|--|--------|
| KNECHT/MAHLE (.../...) | |
| LAK246 | 715508 |
| LAK247 | 715648 |
| LAK248 | 715503 |
| LAK249 | 715504 |
| LAK25 | 698745 |
| LAK250 | 715505 |
| LAK251 | 698802 |
| LAK252 | 715507 |
| LAK255 | 698723 |
| LAK278/S | 715621 |
| LAK280 | 715519 |
| LAK292/S | 715643 |
| LAK293 | 715511 |
| LAK294 | 715641 |
| LAK295/S | 715544 |
| LAK297 | 715533 |
| LAK307 | 715602 |
| LAK31 | 698686 |
| LAK32/1 | 698748 |
| LAK345 | 715680 |
| LAK359 | 715637 |
| LAK36 | 698746 |
| LAK364 | 715640 |
| LAK367 | 715590 |
| LAK37 | 698697 |
| LAK385 | 715586 |
| LAK386 | 715580 |
| LAK387 | 715702 |
| LAK410 | 715613 |
| LAK410 | 715614 |
| LAK413 | 715600 |
| LAK426/S | 715607 |
| LAK428/S | 715555 |
| LAK430 | 715608 |
| LAK436 | 715630 |
| LAK437 | 715635 |
| LAK44 | 698679 |
| LAK45 | 715578 |
| LAK454 | 715681 |
| LAK46 | 698682 |
| LAK46 | 698684 |
| LAK463 | 715661 |
| LAK467/S | 715690 |



|  |  |
|---|---|
| KNECHT/MAHLE (.../...) | |
| LAK472 | 715659 |
| LAK478 | 715622 |
| LAK485 | 715546 |
| LAK49 | 715675 |
| LAK52 | 698696 |
| LAK54 | 715512 |
| LAK54/1 | 715571 |
| LAK54/1 | 715571 |
| LAK56 | 698687 |
| LAK57 | 698749 |
| LAK59 | 698748 |
| LAK62 | 698716 |
| LAK62 | 698776 |
| LAK63 | 698716 |
| LAK64 | 698688 |
| LAK70 | 698713 |
| LAK73/S | 698246 |
| LAK74 | 698708 |
| LAK75 | 698709 |
| LAK75 | 698875 |
| LAK78 | 698695 |
| LAK8 | 715677 |
| LAK81 | 698744 |
| LAK93 | 698683 |
| LAK96 | 698774 |
| LAK98 | 698778 |
| LAKG113/S | 698890 |
| LKK116/S | 698742 |
| LKK165/S | 698740 |
| LKK72/S | 698772 |
| MANN HUMMEL | |
| CU1006-2 | 698469 |
| CU1009 | 715598 |
| CU15001 | 715709 |
| CU1519 | 715656 |
| CU1611 | 715637 |
| CU1629 | 715721 |
| CU1719 | 715526 |
| CU1738 | 698794 |
| CU1806-2 | 715576 |
| CU1823 | 715594 |
| CU1828 | 698681 |
| CU1828 | 715550 |



|  |  |
|---|---|
| MANN HUMMEL | |
| CU1829 | 698753 |
| CU1830 | 715603 |
| CU1835 | 698886 |
| CU19000-3 | 715530 |
| CU19004-2 | 715714 |
| CU1910 | 715524 |
| CU1912 | 715689 |
| CU1915 | 715688 |
| CU1919 | 715620 |
| CU1931-2 | 698290 |
| CU1936 | 715559 |
| CU20010 | 715707 |
| CU2012 | 715588 |
| CU2015 | 715565 |
| CU2026 | 698866 |
| CU2033-2 | 698891 |
| CU2035 | 698795 |
| CU2038 | 698160 |
| CU2038 | 715653 |
| CU2040 | 715616 |
| CU2043 | 698870 |
| CU21000-2 | 715556 |
| CU21001 | 715572 |
| CU21001-2 | 715572 |
| CU2106-2 | 715545 |
| CU2127 | 715563 |
| CU2129 | 715668 |
| CU2131 | 698796 |
| CU2131 | 715619 |
| CU2137 | 698769 |
| CU2138 | 715564 |
| CU2138 | 715609 |
| CU2141 | 715631 |
| CU2143 | 698876 |
| CU2145 | 715551 |
| CU2149 | 698594 |
| CU22001-2 | 698892 |
| CU22004 | 715625 |
| CU22007 | 715708 |
| CU22010 | 715718 |
| CU2216-2 | 715569 |
| CU2224-2 | 698712 |
| CU2225 | 698146 |



|  |  |
|---|---|
| MANN HUMMEL | |
| CU2232 | 715532 |
| CU2240 | 698512 |
| CU2243 | 715552 |
| CU2245 | 698657 |
| CU2253 | 698196 |
| CU2253 | 698819 |
| CU23000-2 | 715548 |
| CU23000-2 | 715543 |
| CU23011 | 715706 |
| CU2316 | 698730 |
| CU2321 | 715618 |
| CU2326 | 698773 |
| CU2327 | 698735 |
| CU2327-2 | 698735 |
| CU2329 | 715534 |
| CU2330 | 715535 |
| CU2331 | 715592 |
| CU2335 | 698867 |
| CU2336 | 715521 |
| CU2337 | 698860 |
| CU2339 | 698861 |
| CU2344 | 698691 |
| CU2345 | 698734 |
| CU2349 | 715645 |
| CU2351 | 698869 |
| CU2356 | 715517 |
| CU2358 | 698868 |
| CU2362 | 715541 |
| CU2422 | 715686 |
| CU2423 | 698817 |
| CU2424 | 698279 |
| CU2424 | 698276 |
| CU2425 | 698175 |
| CU2430 | 698736 |
| CU2433 | 698693 |
| CU2433 | 698694 |
| CU2435 | 698279 |
| CU2436 | 715660 |
| CU2440 | 715510 |
| CU2440 | 715627 |
| CU2442 | 715658 |
| CU2450 | 715579 |
| CU2454 | 715540 |



|  |  |
|---|---|
| MANN HUMMEL | |
| CU2504 | 698690 |
| CU2506-2 | 715525 |
| CU2516 | 715549 |
| CU2520 | 698819 |
| CU2520 | 698196 |
| CU2521-2 | 715523 |
| CU2521-2 | 715618 |
| CU2525 | 698173 |
| CU2525/1 | 698173 |
| CU2530 | 698707 |
| CU2533-2 | 715715 |
| CU2542-2 | 715529 |
| CU2544 | 715636 |
| CU2545 | 698685 |
| CU2559 | 698882 |
| CU26000-2 | 715522 |
| CU2620 | 715724 |
| CU2622 | 715654 |
| CU2623 | 715520 |
| CU2628 | 715516 |
| CU2630 | 698731 |
| CU2631 | 715638 |
| CU2634 | 715591 |
| CU2642 | 698878 |
| CU2645 | 698859 |
| CU2647 | 698888 |
| CU2650 | 698770 |
| CU2672 | 698163 |
| CU2672 | 698679 |
| CU2680 | 698680 |
| CU2709 | 715528 |
| CU2733 | 715597 |
| CU2734 | 698177 |
| CU2734 | 698276 |
| CU2745-2 | 715531 |
| CU2747 | 715518 |
| CU2757 | 698663 |
| CU2757 | 698708 |
| CU2808-2 | 715561 |
| CU2835 | 698171 |
| CU2839 | 715573 |
| CU2842 | 715581 |
| CU2855 | 698771 |

|  |  |
|---|---|
| MANN HUMMEL | |
| CU2855/1 | 715687 |
| CU2861 | 698235 |
| CU2882 | 698159 |
| CU2882 | 698885 |
| CU2897 | 698169 |
| CU2930 | 698176 |
| CU2939 | 698800 |
| CU2940 | 698664 |
| CU2941-2 | 715583 |
| CU2945 | 698255 |
| CU2949 | 698790 |
| CU2949-2 | 698790 |
| CU2951 | 698197 |
| CU2951-1 | 698689 |
| CU3020 | 698454 |
| CU3023 | 715500 |
| CU3023-2 | 715500 |
| CU3032 | 698149 |
| CU3037 | 698606 |
| CU3039-2 | 715554 |
| CU3040 | 715587 |
| CU3054 | 698662 |
| CU3054 | 698709 |
| CU3054 | 698874 |
| CU3059 | 698167 |
| CU3124-2 | 698856 |
| CU3136 | 698172 |
| CU3136 | 698199 |
| CU3138 | 698198 |
| CU3139 | 698863 |
| CU3139-2 | 698863 |
| CU3172 | 698702 |
| CU3192 | 715683 |
| CU3337 | 698711 |
| CU3338 | 698170 |
| CU3340 | 698203 |
| CU3435 | 715646 |
| CU3448 | 698488 |
| CU3454 | 715513 |
| CU3455 | 698166 |
| CU3461 | 698700 |
| CU3461-1 | 698701 |
| CU3518 | 698540 |

|  |  |
|---|---|
| MANN HUMMEL | |
| CU3540 | 698871 |
| CU3540 | 698871 |
| CU3553 | 698201 |
| CU3554 | 715617 |
| CU3567 | 698487 |
| CU3569 | 715601 |
| CU3642-2 | 698838 |
| CU3649 | 698762 |
| CU3759 | 715577 |
| CU3780 | 698475 |
| CU3822-2 | 715684 |
| CU3840 | 715562 |
| CU3847 | 715613 |
| CU3847 | 715614 |
| CU3858 | 698840 |
| CU3942 | 698174 |
| CU3943 | 698879 |
| CU3955 | 698164 |
| CU4007 | 698704 |
| CU4007-1 | 698706 |
| CU4151 | 698202 |
| CU4179 | 698738 |
| CU4251 | 698165 |
| CU4416 | 715514 |
| CU4436 | 715585 |
| CU4442 | 698858 |
| CU4624 | 698724 |
| CU4727 | 715670 |
| CU5141 | 698779 |
| CU5257 | 698168 |
| CU5366 | 698775 |
| CU5480 | 698247 |
| CU6724 | 698489 |
| CU8430 | 715502 |
| CU27007 | 715716 |
| CU27008 | 715717 |
| CUK1629 | 715722 |
| CUK18000-2 | 698740 |
| CUK1820-2 | 698747 |
| CUK1830 | 698802 |
| CUK19004-2 | 715713 |
| CUK1931-2 | 715568 |
| CUK20000-2 | 698742 |

|  |  |
|---|---|
| MANN HUMMEL | |
| CUK2026 | 715723 |
| CUK2030 | 715681 |
| CUK2032 | 698774 |
| CUK2043 | 715679 |
| CUK20010 | 715710 |
| CUK21000-2 | 715557 |
| CUK2131 | 715619 |
| CUK2132 | 715608 |
| CUK2137 | 715676 |
| CUK2143 | 698877 |
| CUK2145 | 715680 |
| CUK2149 | 698715 |
| CUK22000-2 | 698772 |
| CUK22008-4 | 715712 |
| CUK2227 | 715537 |
| CUK2230 | 715509 |
| CUK2230/1 | 715622 |
| CUK2231 | 715546 |
| CUK2232 | 715533 |
| CUK2241-2 | 715621 |
| CUK2243 | 715553 |
| CUK2245 | 715629 |
| CUK2316 | 715539 |
| CUK2335 | 698839 |
| CUK2338 | 698777 |
| CUK2338 | 698778 |
| CUK2339 | 698862 |
| CUK2358 | 715678 |
| CUK2422 | 698692 |
| CUK2430 | 715610 |
| CUK2433 | 698694 |
| CUK2433 | 698693 |
| CUK2440 | 715511 |
| CUK2440 | 715628 |
| CUK2442 | 715659 |
| CUK2450 | 715580 |
| CUK2533-2 | 715690 |
| CUK2545 | 698739 |
| CUK2551 | 715600 |
| CUK2559 | 698883 |
| CUK2646-2 | 715544 |
| CUK2672 | 698679 |

|  |  |
|---|---|
| MANN HUMMEL | |
| CUK2680 | 715612 |
| CUK2722-2 | 715643 |
| CUK2736-2 | 698246 |
| CUK2742 | 715635 |
| CUK2742 | 715635 |
| CUK2743 | 715673 |
| CUK2747 | 715519 |
| CUK2842 | 698768 |
| CUK2855 | 715512 |
| CUK2855-1 | 715571 |
| CUK2862 | 698716 |
| CUK2882 | 698686 |
| CUK2897 | 698697 |
| CUK2939 | 698801 |
| CUK2939/1 | 715665 |
| CUK2940 | 698714 |
| CUK2941-2 | 715584 |
| CUK2945 | 715538 |
| CUK2949 | 698791 |
| CUK2949-2 | 698791 |
| CUK2951 | 698687 |
| CUK3023 | 715501 |
| CUK3023-2 | 715501 |
| CUK3037 | 698683 |
| CUK3039-2 | 715555 |
| CUK3042 | 698688 |
| CUK3054 | 698875 |
| CUK3059 | 698746 |
| CUK3124-2 | 698857 |
| CUK3137 | 715648 |
| CUK3139 | 698864 |
| CUK3139-2 | 698864 |
| CUK3142 | 698865 |
| CUK3142/1 | 715611 |
| CUK3172 | 698741 |
| CUK3192 | 698682 |
| CUK3220 | 698723 |
| CUK3240 | 698884 |
| CUK3241 | 698751 |
| CUK3337 | 698710 |
| CUK3340 | 698748 |
| CUK3448 | 698749 |

|  |  |
|---|---|
| MANN HUMMEL | |
| CUK3461 | 698743 |
| CUK35000-2 | 698793 |
| CUK3518 | 698541 |
| CUK3540 | 698872 |
| CUK3554 | 715617 |
| CUK3562 | 698684 |
| CUK3567 | 698695 |
| CUK3569 | 715602 |
| CUK3621 | 715508 |
| CUK3642-2 | 698470 |
| CUK3780 | 698744 |
| CUK3840 | 698737 |
| CUK3847 | 715614 |
| CUK3943 | 698880 |
| CUK3955 | 715578 |
| CUK4007-1 | 698705 |
| CUK4054 | 715507 |
| CUK4136 | 698792 |
| CUK4151 | 715675 |
| CUK4179 | 715558 |
| CUK4251 | 715632 |
| CUK4436 | 715586 |
| CUK4624 | 698725 |
| CUK5141 | 698745 |
| CUK5257 | 715674 |
| CUK5258 | 698713 |
| CUK5366 | 698776 |
| CUK5480 | 698696 |
| CUK6724 | 698750 |
| CUK8430 | 715503 |
| MECAFILTER | |
| ELR7017 | 698146 |
| EKR7000 | 715632 |
| EKR7002 | 698746 |
| EKR7003 | 715675 |
| EKR7004 | 698686 |
| EKR7004 | 698716 |
| EKR7005 | 715578 |
| EKR7007 | 715617 |
| EKR7017 | 715677 |
| EKR7027 | 698203 |
| EKR7027 | 698748 |
| EKR7038 | 698682 |

**Valeo****MECAFILTER (.../...)**

| | |
|---------|--------|
| EKR7040 | 698875 |
| EKR7047 | 715538 |
| EKR7049 | 698708 |
| EKR7055 | 698695 |
| EKR7068 | 698749 |
| EKR7073 | 698744 |
| EKR7074 | 698777 |
| EKR7074 | 698778 |
| EKR7075 | 715612 |
| EKR7076 | 698739 |
| EKR7078 | 698535 |
| EKR7078 | 698839 |
| EKR7092 | 698683 |
| EKR7095 | 698715 |
| EKR7096 | 698745 |
| EKR7097 | 698714 |
| EKR7098 | 698750 |
| EKR7104 | 698541 |
| EKR7105 | 715629 |
| EKR7106 | 698710 |
| EKR7106 | 698711 |
| EKR7107 | 698696 |
| EKR7108 | 698776 |
| EKR7117 | 715558 |
| EKR7118 | 715512 |
| EKR7123 | 698737 |
| EKR7124 | 715539 |
| EKR7127 | 698801 |
| EKR7128 | 715511 |
| EKR7128 | 715628 |
| EKR7129 | 698768 |
| EKR7130 | 698693 |
| EKR7131 | 698877 |
| EKR7132 | 698872 |
| EKR7135 | 698865 |
| EKR7136 | 698713 |
| EKR7137 | 715506 |
| EKR7137 | 715507 |
| EKR7142 | 698725 |
| EKR7145 | 698883 |
| EKR7146 | 698741 |
| EKR7148 | 715509 |

**Valeo****MECAFILTER (.../...)**

| | |
|---------|--------|
| EKR7149 | 698792 |
| EKR7151 | 715503 |
| EKR7156 | 698723 |
| EKR7159 | 715650 |
| EKR7162 | 698884 |
| EKR7162 | 715570 |
| EKR7163 | 698862 |
| EKR7165 | 698751 |
| EKR7166 | 715533 |
| EKR7172 | 715508 |
| EKR7174 | 715519 |
| EKR7193 | 698802 |
| EKR7193 | 715603 |
| EKR7197 | 715674 |
| EKR7218 | 715613 |
| EKR7218 | 715614 |
| EKR7220 | 715580 |
| EKR7269 | 715635 |
| ELR7000 | 698165 |
| ELR7001 | 698166 |
| ELR7002 | 698167 |
| ELR7003 | 698202 |
| ELR7004 | 698159 |
| ELR7004 | 698160 |
| ELR7004 | 698679 |
| ELR7005 | 698164 |
| ELR7006 | 698168 |
| ELR7007 | 698201 |
| ELR7009 | 698247 |
| ELR7010 | 698199 |
| ELR7011 | 698174 |
| ELR7013 | 698684 |
| ELR7014 | 698171 |
| ELR7016 | 698170 |
| ELR7018 | 698858 |
| ELR7019 | 698197 |
| ELR7019 | 698687 |
| ELR7020 | 698198 |
| ELR7022 | 698688 |
| ELR7023 | 698697 |
| ELR7026 | 698235 |
| ELR7029 | 698173 |

**Valeo****MECAFILTER (.../...)**

| | |
|---------|--------|
| ELR7030 | 698149 |
| ELR7036 | 698163 |
| ELR7040 | 698662 |
| ELR7040 | 698874 |
| ELR7044 | 698794 |
| ELR7045 | 698177 |
| ELR7047 | 698255 |
| ELR7048 | 698279 |
| ELR7049 | 698663 |
| ELR7050 | 698276 |
| ELR7051 | 698196 |
| ELR7051 | 698819 |
| ELR7051 | 698869 |
| ELR7052 | 698860 |
| ELR7055 | 698487 |
| ELR7056 | 698878 |
| ELR7058 | 698770 |
| ELR7060 | 698691 |
| ELR7061 | 698454 |
| ELR7068 | 698488 |
| ELR7071 | 698176 |
| ELR7072 | 698175 |
| ELR7073 | 698475 |
| ELR7075 | 698680 |
| ELR7076 | 698685 |
| ELR7077 | 698840 |
| ELR7079 | 698689 |
| ELR7081 | 698704 |
| ELR7084 | 698700 |
| ELR7085 | 698701 |
| ELR7089 | 715577 |
| ELR7092 | 698606 |
| ELR7093 | 698773 |
| ELR7094 | 698762 |
| ELR7095 | 698594 |
| ELR7096 | 698779 |
| ELR7097 | 698664 |
| ELR7098 | 698489 |
| ELR7099 | 715645 |
| ELR7100 | 698707 |
| ELR7101 | 698512 |
| ELR7103 | 715513 |

|  | Valeo |
|---|--------------|
| MECAFILTER (.../...) | |
| ELR7104 | 698540 |
| ELR7105 | 698657 |
| ELR7108 | 698775 |
| ELR7109 | 698690 |
| ELR7110 | 698879 |
| ELR7111 | 715683 |
| ELR7113 | 698734 |
| ELR7117 | 698738 |
| ELR7118 | 698771 |
| ELR7119 | 698692 |
| ELR7120 | 698867 |
| ELR7122 | 698681 |
| ELR7123 | 715562 |
| ELR7124 | 698730 |
| ELR7125 | 698817 |
| ELR7126 | 698731 |
| ELR7127 | 698800 |
| ELR7128 | 715510 |
| ELR7128 | 715627 |
| ELR7129 | 715581 |
| ELR7130 | 698694 |
| ELR7131 | 698876 |
| ELR7132 | 698871 |
| ELR7134 | 698736 |
| ELR7138 | 715514 |
| ELR7140 | 715631 |
| ELR7142 | 698724 |
| ELR7143 | 698866 |
| ELR7144 | 698886 |
| ELR7145 | 698882 |
| ELR7146 | 698702 |
| ELR7151 | 715502 |
| ELR7154 | 715542 |
| ELR7157 | 698753 |
| ELR7159 | 698796 |
| ELR7159 | 715550 |
| ELR7159 | 715619 |
| ELR7163 | 698861 |
| ELR7164 | 698795 |
| ELR7166 | 715532 |
| ELR7168 | 698870 |
| ELR7173 | 698868 |
| ELR7176 | 715565 |



|  | Valeo |
|---|--------------|
| MECAFILTER (.../...) | |
| ELR7180 | 715517 |
| ELR7181 | 698888 |
| ELR7185 | 715636 |
| ELR7187 | 715552 |
| ELR7187 | 715553 |
| ELR7191 | 715549 |
| ELR7194 | 715547 |
| ELR7195 | 715540 |
| ELR7196 | 698769 |
| ELR7198 | 715526 |
| ELR7199 | 715535 |
| ELR7206 | 715521 |
| ELR7207 | 715541 |
| ELR7212 | 715620 |
| ELR7213 | 715515 |
| ELR7214 | 715689 |
| ELR7215 | 715615 |
| ELR7216 | 715573 |
| ELR7219 | 715559 |
| ELR7220 | 715579 |
| ELR7244 | 715667 |
| ELR7245 | 715660 |
| ELR7259 | 698895 |
| ELR7261 | 715638 |
| ELR7263 | 715658 |
| ELR7267 | 715609 |
| ELR7523 | 715595 |
| JKR7046 | 715568 |
| JKR7066 | 698470 |
| JKR7086 | 698742 |
| JKR7088 | 698772 |
| JKR7090 | 698747 |
| JKR7091 | 698791 |
| JKR7121 | 698857 |
| JKR7133 | 698740 |
| JKR7158 | 715501 |
| JKR7161 | 698864 |
| JKR7201 | 715544 |
| JKR7217 | 715556 |
| JKR7217 | 715557 |
| JKR7231 | 715607 |
| JKR7234 | 715555 |
| JLR7015 | 698246 |



|  | Valeo |
|---|--------------|
| MECAFILTER (.../...) | |
| JLR7039 | 698712 |
| JLR7046 | 698290 |
| JLR7054 | 715575 |
| JLR7064 | 715530 |
| JLR7065 | 698469 |
| JLR7080 | 715684 |
| JLR7087 | 698169 |
| JLR7087 | 715531 |
| JLR7091 | 698790 |
| JLR7116 | 698891 |
| JLR7121 | 698856 |
| JLR7150 | 715598 |
| JLR7152 | 698735 |
| JLR7158 | 715500 |
| JLR7160 | 715561 |
| JLR7161 | 698863 |
| JLR7167 | 715664 |
| JLR7190 | 715569 |
| JLR7204 | 715520 |
| JLR7205 | 698892 |
| JLR7209 | 715668 |
| JLR7210 | 715572 |
| JLR7229 | 715525 |
| JLR7230 | 715536 |
| JLR7234 | 715554 |
| JLR7243 | 715649 |
| MICRONAIR | |
| MC505 | 698697 |
| MC511 | 715578 |
| MC514 | 698875 |
| MC514 | 698709 |
| MC515 | 698746 |
| MC517 | 715617 |
| MC522-2 | 698697 |
| MC522-2 | 698772 |
| MC525 | 698696 |
| MC526 | 698697 |
| MC530 | 698246 |
| MC530-2 | 698246 |
| MC533 | 715538 |
| MC537 | 698744 |
| MC538 | 698750 |
| MC539 | 698687 |



|  Valeo | |
|--|--------|
| MICRONAIR (.../...) | |
| MC539 | 698197 |
| MC540 | 698687 |
| MC541 | 698695 |
| MC544 | 698686 |
| MC547 | 698708 |
| MC548 | 698684 |
| MC549 | 698682 |
| MC555 | 698748 |
| MC557 | 698749 |
| MC559 | 698743 |
| MC560 | 698739 |
| MC561 | 698680 |
| MC564 | 698715 |
| MC568-2 | 715568 |
| MC571 | 698714 |
| MC574 | 698701 |
| MC578 | 698839 |
| MC578 | 698535 |
| MC590 | 698774 |
| MC591 | 698688 |
| MC592 | 698716 |
| MC593-2 | 698470 |
| MC593-2 | 698838 |
| MC594 | 698778 |
| MC595-2 | 698747 |
| MC596 | 698692 |
| MC597 | 698745 |
| MC597 | 698779 |
| MC598 | 698751 |
| MC599 | 698725 |
| MC600-2 | 698791 |
| MC606 | 698683 |
| MC606 | 698606 |
| MC607 | 698710 |
| MC608-2 | 715621 |
| MC609 | 698741 |
| MC611-2 | 698857 |
| MC612 | 698862 |
| MC613 | 698801 |
| MC614 | 698693 |
| MC615 | 698737 |
| MC616 | 698738 |
| MC618 | 715504 |

|  Valeo | |
|--|--------|
| MICRONAIR (.../...) | |
| MC619 | 715505 |
| MC622 | 698865 |
| MC623 | 715611 |
| MC624-2 | 698890 |
| MC630 | 698725 |
| MC639 | 698877 |
| MC640 | 698884 |
| MC641 | 698768 |
| MC642 | 698883 |
| MC643 | 715590 |
| MC644-2 | 698793 |
| MC645 | 715511 |
| MC646 | 715512 |
| MC648 | 698872 |
| MC649 | 698776 |
| MC659 | 698713 |
| MC661 | 715507 |
| MC666-2 | 698864 |
| MC667 | 715539 |
| MC669 | 715571 |
| MC670 | 698802 |
| MC673 | 715629 |
| MC675 | 715508 |
| MC676 | 715519 |
| MC681 | 715628 |
| MC685 | 715501 |
| MC688 | 698541 |
| MC689 | 698723 |
| MC694 | 698710 |
| MC695 | 715503 |
| MC700 | 715533 |
| MC701-2 | 715555 |
| MC721 | 698873 |
| MC738-2 | 715544 |
| MC739-2 | 715643 |
| MC747 | 715509 |
| MC748 | 715648 |
| MP002 | 698170 |
| MP003 | 698171 |
| MP004 | 698704 |
| MP005 | 698169 |
| MP009 | 698165 |
| MP011 | 698164 |

|  Valeo | |
|--|--------|
| MICRONAIR (.../...) | |
| MP012 | 698235 |
| MP013 | 698858 |
| MP014 | 698874 |
| MP014 | 698662 |
| MP015 | 698167 |
| MP017 | 698201 |
| MP017 | 715617 |
| MP018 | 698166 |
| MP019 | 698704 |
| MP019 | 698706 |
| MP020 | 698840 |
| MP021 | 698198 |
| MP022-2 | 715531 |
| MP023 | 715577 |
| MP024 | 698794 |
| MP025 | 698247 |
| MP025 | 698794 |
| MP026 | 698169 |
| MP027 | 698199 |
| MP028 | 715534 |
| MP029 | 698196 |
| MP030-2 | 698246 |
| MP031 | 698163 |
| MP032 | 698202 |
| MP033 | 698255 |
| MP034 | 698146 |
| MP036 | 715645 |
| MP037 | 698475 |
| MP038 | 698489 |
| MP039 | 698197 |
| MP040 | 698689 |
| MP041 | 698487 |
| MP042 | 698860 |
| MP044 | 698159 |
| MP044 | 698160 |
| MP044 | 698679 |
| MP044 | 698885 |
| MP045 | 698860 |
| MP046 | 698859 |
| MP047 | 698663 |
| MP047 | 698708 |
| MP049 | 698164 |
| MP050 | 698174 |

|  |  |
|---|---|
| MICRONAIR (.../...) | |
| MP051 | 698173 |
| MP052 | 698149 |
| MP053 | 698172 |
| MP055 | 698203 |
| MP056 | 698770 |
| MP057 | 698488 |
| MP058 | 698712 |
| MP059 | 698700 |
| MP060 | 698685 |
| MP061 | 698680 |
| MP062 | 698878 |
| MP063 | 698734 |
| MP064 | 698594 |
| MP065 | 698279 |
| MP065 | 698276 |
| MP066 | 698735 |
| MP066-2 | 698735 |
| MP068 | 698290 |
| MP068-2 | 698290 |
| MP069 | 698770 |
| MP071 | 698664 |
| MP072 | 698723 |
| MP074 | 698701 |
| MP076 | 698168 |
| MP077 | 698773 |
| MP078 | 698535 |
| MP078 | 698839 |
| MP078 | 698867 |
| MP079 | 715573 |
| MP080 | 698196 |
| MP081 | 698454 |
| MP082 | 698707 |
| MP083-2 | 715593 |
| MP084 | 698279 |
| MP084 | 698276 |
| MP085 | 698769 |
| MP086 | 698771 |
| MP087-3 | 715530 |
| MP088 | 698512 |
| MP089 | 698512 |
| MP094 | 698777 |
| MP097 | 698779 |
| MP100-2 | 698790 |

|  |  |
|---|---|
| MICRONAIR (.../...) | |
| MP101 | 698762 |
| MP104 | 698681 |
| MP105 | 715563 |
| MP105 | 698796 |
| MP106 | 698606 |
| MP106 | 698683 |
| MP107 | 698711 |
| MP109 | 698702 |
| MP110 | 698704 |
| MP111-2 | 698856 |
| MP112 | 698861 |
| MP113 | 698800 |
| MP114 | 698694 |
| MP115 | 698737 |
| MP115 | 715562 |
| MP116 | 698738 |
| MP117 | 698795 |
| MP121 | 715542 |
| MP124-2 | 698891 |
| MP125 | 698753 |
| MP125 | 715549 |
| MP126-2 | 715548 |
| MP126-2 | 715545 |
| MP127 | 715528 |
| MP128-2 | 715572 |
| MP129 | 715565 |
| MP130 | 698724 |
| MP139 | 698876 |
| MP140 | 715570 |
| MP141 | 715581 |
| MP142 | 698882 |
| MP145 | 715510 |
| MP147 | 698870 |
| MP148 | 698871 |
| MP149 | 698775 |
| MP157 | 698731 |
| MP158 | 698886 |
| MP160 | 715594 |
| MP161 | 715506 |
| MP162 | 698893 |
| MP163 | 698866 |
| MP164 | 698865 |
| MP166-2 | 698863 |

|  |  |
|---|---|
| MICRONAIR (.../...) | |
| MP167 | 698730 |
| MP170 | 715603 |
| MP172 | 698870 |
| MP173 | 698657 |
| MP176 | 715518 |
| MP179 | 698753 |
| MP180 | 698868 |
| MP181 | 715627 |
| MP185 | 715500 |
| MP187 | 715516 |
| MP191 | 698691 |
| MP192 | 698690 |
| MP193 | 715532 |
| MP193 | 715552 |
| MP195 | 715502 |
| MP196 | 715521 |
| MP197 | 698895 |
| MP198 | 698886 |
| MP200 | 715532 |
| MP201-2 | 715554 |
| MP202 | 715540 |
| MP203-2 | 715525 |
| MP204 | 698888 |
| MP207 | 715515 |
| MP210 | 715591 |
| MP211 | 715527 |
| MP213 | 715517 |
| MP215-1 | 715523 |
| MP218-1 | 715522 |
| MP218-2 | 715522 |
| MP219 | 715523 |
| MP220 | 715524 |
| MP223 | 715513 |
| MP224 | 715651 |
| MP225 | 715551 |
| MP226-2 | 715576 |
| MP227-2 | 698892 |
| MP228-2 | 698894 |
| MP228-2 | 715574 |
| MP230 | 715564 |
| MP232 | 698196 |
| MP232 | 698819 |
| MP233 | 698879 |

|  | Valeo |
|---|--------------|
| MICRONAIR (.../...) | |
| MP234 | 698799 |
| MP236 | 715546 |
| MP237-2 | 715561 |
| MP237-2 | 698869 |
| MP246 | 715569 |
| MP263 | 715595 |
| MP264 | 715556 |
| MP269 | 715596 |
| MP270 | 715559 |
| MP271 | 715579 |
| MP272 | 715609 |
| MP273 | 715550 |
| MP277 | 715541 |
| MP321 | 698690 |
| MP321 | 715615 |
| MP677 | 715602 |
| MP693 | 715553 |
| MP771 | 715580 |
| PURFLUX | |
| AH101 | 698146 |
| AH102 | 698203 |
| AH103 | 698168 |
| AH103 | 698779 |
| AH104 | 698159 |
| AH104 | 698679 |
| AH104 | 698885 |
| AH105 | 698166 |
| AH106 | 698165 |
| AH107 | 698197 |
| AH108 | 698198 |
| AH109 | 698199 |
| AH111 | 698200 |
| AH114 | 698235 |
| AH116 | 698149 |
| AH117 | 698173 |
| AH119 | 698164 |
| AH120 | 698171 |
| AH121 | 698174 |
| AH122 | 698201 |
| AH123 | 698472 |
| AH124 | 698202 |
| AH125 | 698163 |
| AH126 | 698475 |

|  | Valeo |
|---|--------------|
| PURFLUX (.../...) | |
| AH127 | 698196 |
| AH128 | 698167 |
| AH129 | 698247 |
| AH132 | 698176 |
| AH133 | 698177 |
| AH135 | 715653 |
| AH137 | 715531 |
| AH138 | 698169 |
| AH138 | 698697 |
| AH140 | 698488 |
| AH141 | 715633 |
| AH142 | 698878 |
| AH143 | 698255 |
| AH144 | 698279 |
| AH147 | 715683 |
| AH149 | 698770 |
| AH150 | 698276 |
| AH151 | 715572 |
| AH154 | 698535 |
| AH157 | 698712 |
| AH158 | 698840 |
| AH159 | 715577 |
| AH160 | 698681 |
| AH160 | 715619 |
| AH163 | 698290 |
| AH165 | 698869 |
| AH166 | 698680 |
| AH167 | 698487 |
| AH169 | 698512 |
| AH170 | 698662 |
| AH170 | 698874 |
| AH171 | 698663 |
| AH171 | 698708 |
| AH173 | 698771 |
| AH174 | 698691 |
| AH175 | 698773 |
| AH179 | 698664 |
| AH180 | 698731 |
| AH182 | 698794 |
| AH184 | 698606 |
| AH185 | 698594 |
| AH186 | 715513 |
| AH187 | 698489 |

|  | Valeo |
|---|--------------|
| PURFLUX (.../...) | |
| AH189 | 698795 |
| AH191 | 698685 |
| AH193 | 698657 |
| AH194 | 698700 |
| AH194 | 698743 |
| AH195 | 698694 |
| AH198 | 698711 |
| AH199 | 698730 |
| AH201 | 698867 |
| AH202 | 698800 |
| AH203 | 715562 |
| AH204 | 698734 |
| AH205 | 698738 |
| AH206 | 698876 |
| AH207 | 698753 |
| AH209 | 715581 |
| AH210 | 698796 |
| AH212 | 698882 |
| AH212 | 715627 |
| AH214 | 715573 |
| AH220 | 698735 |
| AH221 | 698868 |
| AH222 | 698817 |
| AH223 | 715515 |
| AH224 | 698762 |
| AH225 | 698707 |
| AH226 | 698860 |
| AH227 | 698879 |
| AH228 | 715514 |
| AH229 | 698799 |
| AH230 | 698888 |
| AH231 | 698858 |
| AH233 | 698866 |
| AH234 | 698736 |
| AH238 | 715510 |
| AH244 | 715552 |
| AH245 | 715556 |
| AH248 | 715521 |
| AH249 | 698886 |
| AH250 | 715532 |
| AH251 | 698892 |
| AH255 | 715689 |
| AH256 | 715550 |

|  | Valeo |
|---|--------------|
| PURFLUX (.../...) | |
| AH257 | 715517 |
| AH259 | 715620 |
| AH260 | 715541 |
| AH261 | 715554 |
| AH263 | 715636 |
| AH265 | 715616 |
| AH266 | 715540 |
| AH267 | 715597 |
| AH270 | 715638 |
| AH273 | 715649 |
| AH280 | 698871 |
| AH282 | 715660 |
| AH289 | 698769 |
| AH297 | 698777 |
| AH301 | 715524 |
| AHC101 | 715677 |
| AHC102 | 698748 |
| AHC103 | 698745 |
| AHC107 | 698687 |
| AHC112 | 715530 |
| AHC113 | 698732 |
| AHC119 | 715578 |
| AHC120 | 698171 |
| AHC122 | 715617 |
| AHC124 | 715675 |
| AHC126 | 698744 |
| AHC128 | 698746 |
| AHC129 | 698696 |
| AHC130 | 698170 |
| AHC134 | 698246 |
| AHC136 | 698679 |
| AHC139 | 698684 |
| AHC140 | 698749 |
| AHC142 | 698878 |
| AHC143 | 715538 |
| AHC145 | 698791 |
| AHC147 | 698682 |
| AHC149 | 698770 |
| AHC153 | 698454 |
| AHC154 | 698839 |
| AHC156 | 698688 |
| AHC166 | 715612 |

|  | Valeo |
|---|--------------|
| PURFLUX (.../...) | |
| AHC167 | 698695 |
| AHC169 | 698512 |
| AHC177 | 698747 |
| AHC178 | 698716 |
| AHC179 | 698714 |
| AHC181 | 698713 |
| AHC183 | 698540 |
| AHC183 | 698541 |
| AHC184 | 698683 |
| AHC185 | 698715 |
| AHC187 | 698750 |
| AHC188 | 698774 |
| AHC190 | 698692 |
| AHC191 | 698739 |
| AHC192 | 698725 |
| AHC195 | 698693 |
| AHC198 | 698710 |
| AHC199 | 715539 |
| AHC200 | 698751 |
| AHC202 | 698801 |
| AHC203 | 698737 |
| AHC205 | 715558 |
| AHC208 | 698870 |
| AHC211 | 698741 |
| AHC212 | 698883 |
| AHC213 | 698884 |
| AHC215 | 698740 |
| AHC219 | 698864 |
| AHC237 | 715507 |
| AHC238 | 715511 |
| AHC239 | 698246 |
| AHC245 | 715557 |
| AHC246 | 715503 |
| AHC247 | 715501 |
| AHC250 | 715533 |
| AHC258 | 715613 |
| AHC261 | 715555 |
| AHC264 | 715607 |
| AHC268 | 715602 |
| AHC269 | 715580 |
| AHC278 | 698802 |
| QUINTON HAZELL | |
| QAP200 | 698165 |

|  | Valeo |
|---|--------------|
| QUINTON HAZELL | |
| QAP201 | 698166 |
| QAP204 | 698198 |
| QAP205 | 698171 |
| QAP206 | 698199 |
| QAP207 | 698168 |
| QAP208 | 698174 |
| QAP212 | 698146 |
| QAP213 | 698159 |
| QAP213 | 698679 |
| QAP213 | 698885 |
| QAP214 | 698164 |
| QAP215 | 698770 |
| QAP216 | 698170 |
| QAP217 | 698197 |
| QAP219 | 698202 |
| QAP220 | 698201 |
| QAP221 | 698707 |
| QAP224 | 698149 |
| QAP225 | 698167 |
| QAP227 | 698173 |
| QAP228 | 698203 |
| QAP232 | 698247 |
| QAP234 | 698196 |
| QAP234 | 698819 |
| QAP235 | 715514 |
| QAP237 | 698858 |
| QAP242 | 698235 |
| QAP244 | 715530 |
| QAP247 | 698869 |
| QAP249 | 698174 |
| QAP253 | 698840 |
| QAP254 | 698172 |
| QAP259 | 698177 |
| QAP260 | 698691 |
| QAP261 | 698663 |
| QAP263 | 698279 |
| QAP264 | 698276 |
| QAP265 | 698196 |
| QAP266 | 698662 |
| QAP266 | 698874 |
| QAP267 | 698487 |
| QAP268 | 698860 |

**Valeo****QUINTON HAZELL**



| | |
|--------|--------|
| QAP269 | 698859 |
| QAP270 | 715633 |
| QAP271 | 698475 |
| QAP273 | 698488 |
| QAP275 | 698790 |
| QAP276 | 698535 |
| QAP277 | 698489 |
| QAP278 | 698690 |
| QAP279 | 715512 |
| QAP281 | 715531 |
| QAP282 | 715575 |
| QAP284 | 698290 |
| QAP285 | 698255 |
| QAP286 | 715561 |
| QAP287 | 698838 |
| QAP298 | 698469 |
| QAP309 | 698454 |
| QAP311 | 698700 |
| QAP313 | 698734 |
| QAP314 | 698773 |
| QAP315 | 715646 |
| QAP316 | 698878 |
| QAP317 | 698512 |
| QAP318 | 698681 |
| QAP319 | 698879 |
| QAP320 | 698680 |
| QAP321 | 698771 |
| QAP321 | 715512 |
| QAP322 | 698711 |
| QAP324 | 698685 |
| QAP325 | 715670 |
| QAP327 | 698712 |
| QAP328 | 698606 |
| QAP329 | 698594 |
| QAP330 | 698779 |
| QAP333 | 698769 |
| QAP334 | 698775 |
| QAP337 | 698867 |
| QAP338 | 698657 |
| QAP340 | 698891 |
| QAP343 | 698196 |
| QAP343 | 715573 |



**Valeo****QUINTON HAZELL**



| | |
|--------|--------|
| QAP344 | 698664 |
| QAP345 | 715517 |
| QAP346 | 698888 |
| QAP347 | 698796 |
| QAP351 | 715548 |
| QAP351 | 715549 |
| QAP352 | 698794 |
| QAP353 | 715594 |
| QAP354 | 698735 |
| QAP355 | 698795 |
| QAP356 | 698856 |
| QAP357 | 698702 |
| QAP360 | 715516 |
| QAP361 | 715527 |
| QAP362 | 698738 |
| QAP363 | 698762 |
| QAP366 | 698694 |
| QAP367 | 698800 |
| QAP371 | 698876 |
| QAP372 | 698870 |
| QAP373 | 698753 |
| QAP374 | 715562 |
| QAP375 | 698736 |
| QAP376 | 698730 |
| QAP380 | 715626 |
| QAP381 | 698886 |
| QAP382 | 715551 |
| QAP383 | 715522 |
| QAP385 | 715523 |
| QAP387 | 698866 |
| QAP388 | 698724 |
| QAP389 | 698540 |
| QAP390 | 698882 |
| QAP390 | 715510 |
| QAP391 | 715534 |
| QAP392 | 698871 |
| QAP393 | 715500 |
| QAP394 | 698868 |
| QAP395 | 698893 |
| QAP396 | 698863 |
| QAP397 | 698892 |
| QAP398 | 715535 |

**Valeo****QUINTON HAZELL**

| | |
|--------|--------|
| QAP399 | 715587 |
| QAP400 | 715524 |
| QAP401 | 715526 |
| QAP402 | 715521 |
| QAP403 | 715506 |
| QAP404 | 715627 |
| QAP405 | 715563 |
| QAP405 | 715619 |
| QAP406 | 715570 |
| QAP408 | 698895 |
| QAP409 | 715502 |
| QAP410 | 715520 |
| QAP412 | 715529 |
| QAP414 | 698861 |
| QAP417 | 715518 |
| QAP420 | 715552 |
| QAP420 | 715553 |
| QAP423 | 715620 |
| QAP424 | 715588 |
| QAP425 | 715595 |
| QAP427 | 715592 |
| QAP428 | 715601 |
| QAP429 | 715540 |
| QAP430 | 715636 |
| QAP432 | 715585 |
| QAP432 | 715586 |
| QAP433 | 715554 |
| QAP436 | 715583 |
| QAP437 | 715642 |
| QAP438 | 715616 |
| QAP439 | 715644 |
| QAP500 | 715632 |
| QAP502 | 698682 |
| QAP513 | 698686 |
| QAP525 | 698746 |
| QAP528 | 698748 |
| QAP532 | 698696 |
| QAP533 | 698697 |
| QAP538 | 698246 |
| QAP545 | 698716 |
| QAP552 | 698688 |
| QAP556 | 698684 |

|  |  |
|---|---|
| QUINTON HAZELL | |
| QAP561 | 698708 |
| QAP566 | 698709 |
| QAP566 | 698875 |
| QAP567 | 698695 |
| QAP571 | 698744 |
| QAP573 | 698749 |
| QAP575 | 698791 |
| QAP576 | 698839 |
| QAP577 | 698750 |
| QAP580 | 698774 |
| QAP584 | 715568 |
| QAP585 | 715538 |
| QAP587 | 698470 |
| QAP611 | 698742 |
| QAP611 | 698743 |
| QAP612 | 698778 |
| QAP619 | 698880 |
| QAP622 | 698710 |
| QAP624 | 698739 |
| QAP626 | 698747 |
| QAP628 | 698683 |
| QAP629 | 698715 |
| QAP630 | 698745 |
| QAP632 | 698873 |
| QAP634 | 698776 |
| QAP638 | 715629 |
| QAP639 | 698865 |
| QAP640 | 698890 |
| QAP642 | 698731 |
| QAP644 | 698714 |
| QAP649 | 698692 |
| QAP650 | 715509 |
| QAP656 | 698857 |
| QAP657 | 698740 |
| QAP657 | 698772 |
| QAP659 | 698751 |
| QAP662 | 715558 |
| QAP666 | 698693 |
| QAP667 | 698801 |
| QAP668 | 715560 |
| QAP670 | 698768 |
| QAP671 | 698877 |
| QAP674 | 698737 |

|  |  |
|---|---|
| QUINTON HAZELL | |
| QAP675 | 715610 |
| QAP677 | 715508 |
| QAP682 | 715680 |
| QAP686 | 698713 |
| QAP688 | 698725 |
| QAP689 | 698541 |
| QAP690 | 698883 |
| QAP690 | 715511 |
| QAP692 | 698872 |
| QAP693 | 715501 |
| QAP696 | 698864 |
| QAP703 | 715507 |
| QAP706 | 698884 |
| QAP707 | 698802 |
| QAP709 | 715503 |
| QAP714 | 698862 |
| QAP731 | 715613 |
| QAP731 | 715614 |
| QAP733 | 715555 |
| QAP741 | 715635 |
| WP6802 | 715645 |
| WP6809 | 715578 |
| WP6812 | 698160 |
| WP6814 | 715677 |
| WP6819 | 715675 |
| WP6820 | 715617 |
| WP6864 | 715683 |
| WP6878 | 698704 |
| WP6890 | 698163 |
| WP6898 | 715653 |
| WP6930 | 698176 |
| WP6934 | 698169 |
| WP6978 | 715577 |
| WP9091 | 715676 |
| WP9092 | 698689 |
| WP9115 | 715612 |
| WP9166 | 715581 |
| WP9173 | 698792 |
| WP9175 | 715539 |
| WP9181 | 698723 |
| WP9190 | 698799 |
| WP9202 | 698175 |
| WP9204 | 715572 |

|  |  |
|---|---|
| QUINTON HAZELL | |
| WP9240 | 715528 |
| WP9244 | 715525 |
| WP9246 | 715513 |
| WP9257 | 715556 |
| WP9257 | 715557 |
| WP9260 | 715532 |
| WP9263 | 715544 |
| WP9265 | 715643 |
| WP9276 | 715515 |
| WP9280 | 715615 |
| WP9288 | 715688 |
| WP9294 | 715631 |
| WP9298 | 715541 |
| WP9308 | 715597 |
| WP9313 | 715546 |
| WP9332 | 715684 |
| WP9336 | 715649 |
| WP9339 | 715584 |
| WP9343 | 715519 |
| WP9356 | 715658 |
| TECNOCAR | |
| E302 | 698198 |
| E304 | 698199 |
| E305 | 698197 |
| E306 | 698203 |
| E307 | 698165 |
| E308 | 698146 |
| E309 | 698174 |
| E310 | 698166 |
| E311 | 698159 |
| E311 | 698885 |
| E312 | 698168 |
| E313 | 698164 |
| E315 | 715530 |
| E317 | 698235 |
| E319 | 698149 |
| E320 | 698173 |
| E321 | 698201 |
| E323 | 698201 |
| E323 | 715617 |
| E327 | 698475 |
| E329 | 698247 |
| E330 | 698170 |

|  | Valeo |
|---|--------------|
| TECNOCAR (.../...) | |
| E337 | 698169 |
| E341 | 698488 |
| E343 | 698878 |
| E344 | 698255 |
| E345 | 698177 |
| E346 | 698167 |
| E348 | 698279 |
| E354 | 698290 |
| E359 | 715619 |
| E363 | 698487 |
| E366 | 698662 |
| E366 | 698663 |
| E369 | 698771 |
| E372 | 698680 |
| E373 | 698773 |
| E382 | 698664 |
| E383 | 698731 |
| E394 | 698680 |
| E397 | 698700 |
| E400 | 698711 |
| E403 | 698535 |
| E407 | 698734 |
| E410 | 698876 |
| E416 | 715627 |
| E442 | 715510 |
| EC305 | 698687 |
| EC323 | 715617 |
| EC355 | 698688 |
| EC380 | 698747 |
| EC382 | 698714 |
| EC388 | 698715 |
| EC393 | 698692 |
| EC398 | 698693 |
| EC400 | 698710 |
| ZAFFO | |
| Z016 | 698840 |
| Z049 | 715595 |
| Z050 | 715601 |
| Z050 | 715602 |
| Z300 | 698199 |
| Z314 | 698171 |
| Z318 | 698165 |
| Z318 | 715632 |

|  | Valeo |
|---|--------------|
| ZAFFO (.../...) | |
| Z318 | 715675 |
| Z319 | 698166 |
| Z323 | 698170 |
| Z328 | 698168 |
| Z328 | 698779 |
| Z328 | 715674 |
| Z329 | 698159 |
| Z329 | 698160 |
| Z329 | 698679 |
| Z329 | 698686 |
| Z329 | 698885 |
| Z330 | 698697 |
| Z332 | 698163 |
| Z333 | 698235 |
| Z335 | 698172 |
| Z338 | 698704 |
| Z340 | 715514 |
| Z341 | 698146 |
| Z341 | 715677 |
| Z345 | 698688 |
| Z346 | 715530 |
| Z347 | 698167 |
| Z348 | 698164 |
| Z348 | 715578 |
| Z350 | 698197 |
| Z350 | 698687 |
| Z350 | 698689 |
| Z352 | 698682 |
| Z353 | 698173 |
| Z355 Couple | 715531 |
| Z356 | 698201 |
| Z356 | 715617 |
| Z357 | 698247 |
| Z357 | 698696 |
| Z359 Couple | 698246 |
| Z359 Couple | 715685 |
| Z360 | 698149 |
| Z362 | 698174 |
| Z368 | 698177 |
| Z370 | 698198 |
| Z371 | 698858 |
| Z372 | 698691 |
| Z374 | 698684 |

|  | Valeo |
|---|--------------|
| ZAFFO (.../...) | |
| Z376 | 698663 |
| Z376 | 698708 |
| Z377 | 698723 |
| Z378 | 698770 |
| Z379 Couple | 698290 |
| Z379 Couple | 715568 |
| Z380 | 698279 |
| Z381 | 715538 |
| Z382 | 698276 |
| Z383 | 698196 |
| Z383 | 698819 |
| Z383 | 698869 |
| Z385 | 698662 |
| Z385 | 698709 |
| Z385 | 698874 |
| Z385 | 698875 |
| Z386 | 698487 |
| Z386 | 698695 |
| Z387 | 698454 |
| Z388 | 698860 |
| Z389 | 698859 |
| Z390 | 698716 |
| Z391 Couple | 715561 |
| Z392 | 698255 |
| Z392 | 715633 |
| Z394 | 698475 |
| Z394 | 698744 |
| Z396 | 698707 |
| Z397 | 698488 |
| Z397 | 698749 |
| Z398 | 698683 |
| Z399 | 698790 |
| Z399 | 698791 |
| Z400 | 698535 |
| Z403 | 698489 |
| Z403 | 698750 |
| Z404 Couple | 698470 |
| Z404 Couple | 698838 |
| Z406 | 698690 |
| Z407 | 698771 |
| Z408 | 698774 |
| Z409 | 698777 |
| Z409 | 698778 |

|  | Valeo |
|---|--------------|
| ZAFFO (.../...) | |
| Z410 | 715646 |
| Z411 | 698734 |
| Z412 | 698203 |
| Z412 | 698748 |
| Z413 | 698773 |
| Z414 | 698681 |
| Z414 | 715650 |
| Z415 | 698878 |
| Z416 | 698700 |
| Z416 | 698742 |
| Z416 | 698743 |
| Z417 | 698512 |
| Z418 | 698879 |
| Z418 | 698880 |
| Z419 | 698680 |
| Z419 | 715612 |
| Z420 | 715512 |
| Z421 | 698710 |
| Z422 | 698775 |
| Z422 | 698776 |
| Z423 | 698739 |
| Z424 | 698685 |
| Z425 | 715670 |
| Z426 Couple | 698747 |
| Z427 Couple | 698712 |
| Z428 | 698606 |
| Z429 | 698594 |
| Z429 | 698715 |
| Z430 | 698745 |
| Z431 | 698746 |
| Z432 Couple | 698873 |
| Z434 | 698769 |
| Z434 | 715676 |
| Z436 | 698839 |
| Z436 | 698867 |
| Z437 | 698657 |
| Z437 | 715629 |
| Z438 | 698865 |
| Z439 Couple | 698890 |
| Z439 Couple | 698891 |
| Z440 | 715549 |
| Z441 | 698731 |

|  | Valeo |
|---|--------------|
| ZAFFO (.../...) | |
| Z442 | 715542 |
| Z444 | 715573 |
| Z445 | 715626 |
| Z446 | 698664 |
| Z446 | 698714 |
| Z447 | 715517 |
| Z447 | 715591 |
| Z448 | 698888 |
| Z450 | 715572 |
| Z451 | 698692 |
| Z451 | 715686 |
| Z452 | 715509 |
| Z453 Couple | 715548 |
| Z454 | 698794 |
| Z455 Couple | 715594 |
| Z456 Couple | 698735 |
| Z457 | 698795 |
| Z458 Couple | 698856 |
| Z458 Couple | 698857 |
| Z459 | 698702 |
| Z459 | 698741 |
| Z461 | 698751 |
| Z462 | 715516 |
| Z463 | 715527 |
| Z464 | 698738 |
| Z464 | 715558 |
| Z465 | 698762 |
| Z466 | 698711 |
| Z467 Couple | 715525 |
| Z468 | 698693 |
| Z468 | 698694 |
| Z469 Couple | 715536 |
| Z470 | 698730 |
| Z470 | 715539 |
| Z472 | 698886 |
| Z472 | 715695 |
| Z473 | 698800 |
| Z473 | 698801 |
| Z473 | 715665 |
| Z474 | 715560 |
| Z474 | 715623 |
| Z474 | 715630 |

|  | Valeo |
|---|--------------|
| ZAFFO (.../...) | |
| Z474 | 715631 |
| Z475 | 715701 |
| Z476 | 698768 |
| Z476 | 715581 |
| Z477 | 698876 |
| Z477 | 698877 |
| Z478 | 698870 |
| Z478 | 715679 |
| Z479 | 715551 |
| Z479 | 715680 |
| Z480 | 698753 |
| Z480 | 715708 |
| Z481 | 698737 |
| Z481 | 715562 |
| Z482 | 698736 |
| Z482 | 715610 |
| Z483 Couple | 715522 |
| Z485 Couple | 715523 |
| Z486 | 698713 |
| Z487 | 698866 |
| Z487 | 715723 |
| Z488 | 698724 |
| Z488 | 698725 |
| Z489 | 698540 |
| Z489 | 698541 |
| Z490 | 715641 |
| Z491 | 698882 |
| Z491 | 698883 |
| Z492 | 715505 |
| Z493 | 715534 |
| Z494 | 698871 |
| Z494 | 698872 |
| Z495 Couple | 715508 |
| Z496 | 715500 |
| Z496 | 715501 |
| Z497 | 698868 |
| Z498 | 715590 |
| Z499 | 698861 |
| Z499 | 698862 |
| Z500 | 698893 |
| Z501 Couple | 698863 |
| Z501 Couple | 698864 |

|  | Valeo |
|---|---------------|
| ZAFFO (.../...) | |
| Z502 | 698892 |
| Z503 | 715535 |
| Z505 | 715524 |
| Z505 | 715666 |
| Z506 | 715526 |
| Z507 | 715521 |
| Z508 | 715506 |
| Z508 | 715507 |
| Z510 | 715510 |
| Z510 | 715511 |
| Z510 | 715627 |
| Z510 | 715628 |
| Z511 | 698796 |
| Z511 | 715550 |
| Z511 | 715619 |
| Z512 | 698884 |
| Z512 | 715570 |
| Z513 | 698802 |
| Z513 | 715603 |
| Z514 | 698895 |
| Z515 | 715502 |
| Z515 | 715503 |
| Z516 | 715515 |
| Z517 | 715532 |
| Z517 | 715533 |
| Z518 Couple | 698793 |
| Z519 | 715518 |
| Z519 | 715519 |
| Z520 Couple | 715643 |
| Z521 Couple | 715544 |
| Z522 Couple | 715529 |
| Z523 | 715541 |
| Z524 | 715520 |
| Z526 | 715552 |
| Z526 | 715553 |
| Z527 | 715504 |
| Z528 | 715620 |
| Z529 | 715564 |
| Z529 | 715609 |
| Z530 | 715698 |
| Z531 | 715718 |
| Z532 | 715588 |
| | |

|  | Valeo |
|---|---------------|
| ZAFFO (.../...) | |
| Z533 Couple | 715567 |
| Z536 Couple | 715624 |
| Z537 | 715615 |
| Z538 | 715648 |
| Z539 | 715637 |
| Z540 | 715556 |
| Z540 | 715557 |
| Z541 | 715540 |
| Z542 | 715636 |
| Z543 | 715546 |
| Z544 | 715597 |
| Z545 | 715569 |
| Z546 | 715596 |
| Z546 | 715638 |
| Z547 | 698894 |
| Z547 | 715668 |
| Z548 | 715585 |
| Z548 | 715586 |
| Z549 | 715537 |
| Z551 | 715608 |
| Z552 Couple | 715639 |
| Z553 | 715702 |
| Z554 Couple | 715554 |
| Z554 Couple | 715555 |
| Z555 | 715613 |
| Z555 | 715614 |
| Z557 | 715654 |
| Z559 Couple | 715574 |
| Z561 Couple | 715545 |
| Z562 | 715592 |
| Z563 Couple | 715699 |
| Z564 | 715579 |
| Z564 | 715580 |
| Z565 | 715640 |
| Z566 | 715559 |
| Z567 | 715600 |
| Z568 | 715651 |
| Z569 | 715625 |
| Z570 Couple | 715583 |
| Z570 Couple | 715584 |
| Z571 | 715642 |
| Z572 | 715616 |
| | |

|  | Valeo |
|---|---------------|
| ZAFFO (.../...) | |
| Z573 | 715644 |
| Z574 Couple | 715607 |
| Z575 | 715635 |
| Z577 | 715658 |
| Z577 | 715659 |
| Z579 | 715663 |
| Z580 | 715667 |
| Z580 | 715724 |
| Z581 | 715649 |
| Z582 | 715647 |
| Z583 | 715660 |
| Z583 | 715661 |
| Z584 | 715662 |
| Z585 | 715712 |
| Z586 | 715681 |
| Z588 | 715694 |
| Z589 | 715691 |
| Z590 Couple | 715690 |
| Z590 Couple | 715715 |
| Z591 | 715672 |
| Z593 | 715709 |
| Z594 | 715721 |
| Z594 | 715722 |
| Z595 | 715704 |
| Z596 | 715692 |
| Z600 | 715706 |
| Z601 | 715705 |
| Z602 | 715693 |
| Z607 | 715697 |
| Z610 | 715716 |
| Z612 | 715717 |
| Z613 | 715673 |
| Z616 | 715652 |
| Z617 | 715513 |
| ZF375 | 698202 |
| ZF592 Couple | 715696 |
| ZF598 Couple | 715669 |
| ZF608 Couple | 715713 |
| ZF608 Couple | 715714 |
| | |

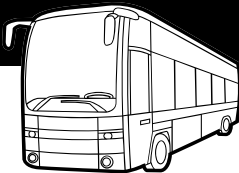
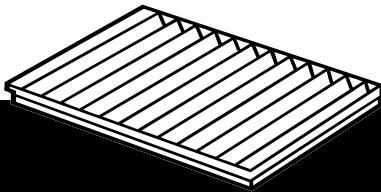

New Nouveau Neu Nuevo Novo Nuovo Nieuw
Nowy Новый Nové Nou Nouă Нов Yeni Néo 196



Valeo

197

clim PUR™ 

clim SPRAY™ 

ROLL MEDIA 

203



Valeo

207



VT01

VT02

VT03

VT04

VT05

VT06

219

Valeo



227



Valeo

234



Valeo

236



Valeo



3

716067

VOLVO TRUCKS

FH II
FM/FMX II (New FM /FMX 2013-)

716068

VOLVO TRUCKS

FH II
FM/FMX II (New FM /FMX 2013-)
T (T308-T520)
K (K308-K520)
C (C380-C520, 2013-)

716069

VOLVO TRUCKS

FH II
FM/FMX II (New FM /FMX 2013-)
T (T308-T520)
K (K308-K520)
C (C380-C520, 2013-)

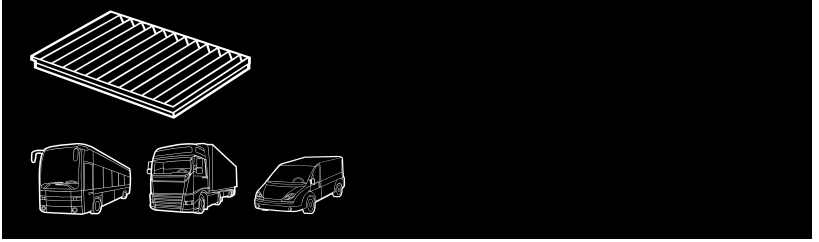











|  | AC |  |  | PA  | CA  | | |
|--|-----|---|---|---|---|---------|---------------|
| DAF  | | | | | | | |
| 65 CF | +/- | | 09/98 ▶ 12/00 | 1347066 | 716004 | | |
| CF 65 | +/- | | 01/01 ▶ | 1347066 | 716004 | | |
| 75 CF | +/- | | 03/98 ▶ 12/00 | 1347066 | 716004 | | |
| CF 75 | +/- | | 01/01 ▶ | 1347066 | 716004 | | |
| 85 CF | +/- | | 03/98 ▶ 12/00 | 1347066 | 716004 | | |
| CF 85 | +/- | | 01/01 ▶ | 1362124 | 716007 | 1362168 | 716008 |
| LF 45 | +/- | | 02/01 ▶ | 1600428 | 716001 | | |
| LF 55 | +/- | | 02/01 ▶ | 1600428 | 716001 | | |
| 95 Serie | +/- | | 09/87 ▶ 01/98 | 1347068 | 716005 | | |
| 95 XF | +/- | | 02/98 ▶ 09/02 | 1658991 | 716006 | | |
| XF 95 | +/- | | 10/02 ▶ | 1658991 | 716006 | | |
| XF 105 | +/- | | 01/06 ▶ | 1658991 | 716006 | | |
| IRISBUS  | | | | | | | |
| Agora | + | | 02/96 ▶ 03/06 | 5006175605 | 716062 | | |
| Agora | + | Webasto | 01/02 ▶ | 1100372A | 716049 | | |
| Ares | + | Webasto | 05/02 ▶ | 1100372A | 716049 | | |
| Arway | + | Webasto | 12/05 ▶ | 1101193 | 716049 | | |
| Axer | + | Webasto | 03/05 ▶ 01/07 | 1100372A | 716049 | | |
| Citelis | + | Webasto | 04/05 ▶ | 1100372A | 716049 | | |
| Citelis/ B | + | | 04/05 ▶ | 5006175605 | 716062 | | |
| City Bus | + | | 09/03 ▶ | 5006175605 | 716062 | | |
| City Class | + | Webasto | 02/00 ▶ | 1101193A | 716049 | | |
| City Class | + | | 01/02 ▶ | 5006175605 | 716062 | | |
| Daily Citis | +/- | | 09/06 ▶ | | | 2994769 | 716063 |
| Evadys | + | Webasto | 09/04 ▶ | 1100372A | 716049 | | |
| Liliade H | + | Webasto | 05/02 ▶ | 1100372A | 716049 | | |
| Midi GX | + | Webasto | 09/04 ▶ | 1100372A | 716049 | | |
| Midys | + | Webasto | 09/04 ▶ | 1101193A | 716049 | | |
| Moovy | + | Webasto | 09/04 ▶ | 1100372A | 716049 | | |
| Recreo | +/- | | 09/06 ▶ | | | 2994769 | 716063 |
| Tourys | +/- | | 09/06 ▶ | | | 2994769 | 716063 |
| Way | +/- | | 09/06 ▶ | | | 2994769 | 716063 |
| IVECO  | | | | | | | |
| Euromover | + | | 04/05 ▶ | 504024890 | 716028 | 2994583 | 716029 |
| Eurostar | +/- | | 04/92 ▶ | 500387947 | 716033 | | |
| Eurotech | +/- | | 04/92 ▶ | 500387947 | 716033 | | |
| Eurotrakker | +/- | | 01/93 ▶ | 500387947 | 716033 | | |
| Stralis | + | | 02/02 ▶ | 504024890 | 716028 | 2994583 | 716029 |
| Trakker | + | | 09/04 ▶ | 504024890 | 716028 | 2994583 | 716029 |
| IVECO  | | | | | | | |
| Campagnola | +/- | | 12/08 ▶ | | | 2994769 | 716063 |

|  | AC |  |  | PA    | CA    | | |
|--|-----|---|---|--|--|-------------|---------------|
| IVECO  (.../...) | | | | | | | |
| Daily (2006>) | + | | 04/06 ▶ | 3802821 | 715595 | 2994769 | 716063 |
| Massif | +/- | | 03/08 ▶ | 3802821 | 715595 | 2994769 | 716063 |
| Rapido | +/- | | 02/07 ▶ | | | 2994769 | 716063 |
| IVECO (BUS)  | | | | | | | |
| Civis | + | Webasto | 05/01 ▶ | 93350A | 716049 | | |
| Euroclass | + | Webasto | 09/02 ▶ | 93350A | 716049 | | |
| Euro Rider | + | Webasto | 09/02 ▶ | 93350A | 716049 | | |
| MAN (BUS)  | | | | | | | |
| Lion's | + | Webasto | 09/96 ▶ | 81779100016 | 716049 | | |
| Lion's City G/GL/GLX | | Konvecta | 02/01 ▶ | 83779720656 | 716064 | | |
| Lion's City LL (NL-Serie) | | Konvecta | 01/99 ▶ | 83779720656 | 716064 | | |
| Lion's City M (NM-Serie) | | Konvecta | 11/05 ▶ | 83779720656 | 716064 | | |
| Lion's City UELL | | Konvecta | 07/98 ▶ | 83779720656 | 716064 | | |
| Lions Coach | +/- | Konvecta | 06/02 ▶ | 88779100002 | 716048 | | |
| Lions Coach | + | Webasto | 07/06 ▶ | 18357047 | 716046 | | |
| Lions Coach | +/- | | 01/98 ▶ 12/01 | 81619100011 | 716034 | | |
| Lions Comfort | +/- | | 01/98 ▶ 12/01 | 81619100011 | 716034 | | |
| Lions Regio | +/- | | 2004 ▶ | 81619100018 | 716036 | | |
| Lions Regio | +/- | | 2004 ▶ | | | 81619100019 | 716037 |
| Lions Series | +/- | Recir.air | 04/00 ▶ | 88779100003 | 716047 | | |
| Lions Series | + | | 09/02 ▶ | 0018355547 | 716056 | | |
| NG | +/- | | 07/98 ▶ | 81779100012 | 716057 | | |
| NG | +/- | Konvecta | 02/01 ▶ | 83779720656 | 716064 | | |
| NL | +/- | | 12/95 ▶ | 81779720155 | 716057 | | |
| NL | +/- | Konvecta | 01/99 ▶ | 83779720656 | 716064 | | |
| NM | +/- | Konvecta | 11/05 ▶ | 83779720656 | 716064 | | |
| NUE | +/- | | 02/98 ▶ | 81779100012 | 716057 | | |
| NUE | +/- | Konvecta | 02/98 ▶ | 83779720656 | 716064 | | |
| UEL-313 | +/- | | 09/96 ▶ 09/01 | 81619100011 | 716034 | | |
| UEL-353 | +/- | | 06/97 ▶ 12/01 | 81619100011 | 716034 | | |
| MAN TRUCKS  | | | | | | | |
| F2000, F2000 Evolution | +/- | | 01/94 ▶ | 81619100011 | 716034 | | |
| FE Serie | +/- | | 08/95 ▶ | 81619100011 | 716034 | | |
| L2000, L2000 Evolution | +/- | | 05/94 ▶ | 85619500025 | 716035 | | |
| LE Serie (250-280) | +/- | | 08/88 ▶ 12/98 | 81619100011 | 716034 | | |
| LE Serie (110-220) | +/- | | 08/00 ▶ | 85619500025 | 716035 | | |
| M2000, M2000 Evolution | +/- | | 05/94 ▶ | 85619500025 | 716035 | | |
| M2000, M2000 Evolution | +/- | | 08/95 ▶ | 81619100011 | 716034 | | |
| ME Serie | +/- | | 08/00 ▶ | 81619100011 | 716034 | | |
| TGA | +/- | | 03/00 ▶ | 81619100018 | 716036 | 81619100019 | 716037 |
| TGL | +/- | | 06/05 ▶ | 81619100018 | 716036 | 81619100019 | 716037 |

|  | AC |  |  | PA  | CA  |
|--|-----|--|---|---|---|
| MAN TRUCKS  (.../...) | | | | | |
| TGM | +/- | | 11/05 ▶ | 81619100018 | 716036 81619100019 716037 |
| MERCEDES  | | | | | |
| Sprinter I | + | | 02/95 ▶ 05/06 | 9018300018 | 698840 9018300418 716023 |
| MERCEDES (EVOBUS/SETRA)  | | | | | |
| CapaCity (O 530GL/628) | | Konnecta | 04/07 ▶ | 0018359247 | 716064 |
| Citaro K (628) | + | Webasto | 09/06 ▶ | 6278350447 | 716049 |
| Citaro LE | + | Webasto | 11/05 ▶ | 20401236 | 716049 |
| Comfort Class 400S | + | | 10/03 ▶ | 0018357147 | 716058 |
| Citaro O530 | - | Konnecta | 03/98 ▶ | 0018359247 | 716064 |
| Integro (633) | - | Konnecta | 03/06 ▶ | 0018359247 | 716064 |
| Intercity (634) | | Konnecta | 09/08 ▶ | 0018359247 | 716064 |
| Intouro II (633) | | Konnecta | 03/07 ▶ | 0018359247 | 716064 |
| O 345 | + | | 03/98 ▶ | 0018355547 | 716056 |
| O 350 | + | | 03/98 ▶ | 0018355547 | 716056 |
| O 345 - Conecto | + | Webasto | 01/03 ▶ | 0018255447 | 716049 |
| O 530 - Citaro | + | Webasto | 01/98 ▶ | 0018255447 | 716049 |
| O 530 - Citaro | + | Konnecta | 03/98 ▶ | H14002499 | 716048 |
| O 530 - Citaro | + | Konnecta | 03/98 ▶ | 0018351547 | 716050 |
| O 530 - Citaro | + | | 03/98 ▶ | 0018359147 | 716060 |
| O 550 - Integro | + | Webasto | 03/06 ▶ | 0018357047 | 716046 |
| O 550 - Integro M | + | Webasto | 09/02 ▶ 03/06 | 0018357047 | 716046 |
| O 580 - Travego | + | Webasto | 11/99 ▶ 01/06 | 0018255447 | 716049 |
| O 580 - Travego | + | | 11/99 ▶ | 0018357147 | 716058 |
| S400 Serie | + | Webasto | 09/01 ▶ | 0018357047 | 716046 |
| Setra S400 | | Konnecta | 10/03 ▶ | 0018359247 | 716064 |
| Setra S400 | + | Webasto | 09/06 ▶ | 0018255447 | 716049 |
| Setra S400 Top Class | + | | 06/02 ▶ | 0018356147 | 716059 |
| Setra S400 Top Class | + | | 06/02 ▶ | 0018356247 | 716061 |
| Tourismo II/M | - | Konnecta | 09/06 ▶ | 0018359247 | 716064 |
| Travego (O 580) | - |  Konnecta | 11/99 ▶ 12/06 | 0018359247 | 716064 |
| MERCEDES TRUCKS  | | | | | |
| Actros | +/- | prefilter | 09/96 ▶ | 0018350747 | 716017 |
| Actros | +/- | Road | 09/96 ▶ | 0008301118 | 716010 0008301318 716012 |
| Actros | + | Construction | 09/96 ▶ | 0008301218 | 716011 |
| Actros | A+ | | 09/96 ▶ | | 0008301518 716013 |
| Actros II | +/- | | 09/11 ▶ | 9608300018 | 716066 9608300118 716065 |
| Atego I | +/- | Construction | 01/98 ▶ 09/04 | 9738350247 | 716021 |
| Atego I | +/- | | 01/98 ▶ 09/04 | 9738350147 | 716014 9738350347 716015 |
| Atego II | +/- | Construction | 09/04 ▶ | 9738350247 | 716021 |
| Atego II | +/- | | 09/04 ▶ | 9738350147 | 716014 9738350347 716015 |
| Axor | +/- | | 10/01 ▶ | 9408350047 | 716019 9408350147 716020 |

|  | AC |  |  | PA    | CA    | | |
|--|-----|---|---|--|--|-------------|---------------|
| MERCEDES TRUCKS  (.../...) | | | | | | | |
| Axor I | +/- | Construction | 01/02 ▶ 09/04 | 9408350247 | 716018 | | |
| Axor II | +/- | | 09/04 ▶ | 9408350047 | 716019 | 9408350147 | 716020 |
| Axor II | +/- | Construction | 09/04 ▶ | 9408350247 | 716018 | | |
| Econic (957) | +/- | | 07/98 ▶ | 9408350047 | 716019 | 9408350147 | 716020 |
| MK Serie | +/- | | 12/87 ▶ 09/96 | 0008356947 | 716016 | | |
| SK Serie | +/- | | 07/87 ▶ 09/96 | 0008356947 | 716016 | | |
| NEOPLAN (NEOMAN)  | | | | | | | |
| Centroliner | +/- | Recir.air | 03/02 ▶ | 88779100003 | 716047 | | |
| Centroliner | + | Webasto | 10/98 ▶ | 0018255447 | 716049 | | |
| Centroliner | +/- | | 10/98 ▶ | 81779100012 | 716057 | | |
| Cityliner | + | Webasto | 07/06 ▶ | 1101891A | 716046 | | |
| Starliner I | + | | 09/96 ▶ | 180412710 | 716055 | | |
| Starliner II | + | Webasto | 07/06 ▶ | 1101891B | 716046 | | |
| Tourliner | +/- | Konvecta | 01/03 ▶ | 88779100002 | 716048 | | |
| Tourliner | +/- | Recir.air | 09/03 ▶ | 88779100003 | 716047 | | |
| Tourliner | + | | 09/03 ▶ | 0018355547 | 716056 | | |
| Transliner | +/- | | 11/90 ▶ | 180740200 | 716054 | | |
| Trendliner | +/- | Recir.air | 09/04 ▶ | 81619100018 | 716036 | | |
| Trendliner | +/- | | 2004 ▶ | | | 81619100019 | 716037 |
| RENAULT TRUCKS  | | | | | | | |
| AE (Magnum) | +/- | | 09/90 ▶ | 5001829129 | 716000 | | |
| Kerax | +/- | | 09/97 ▶ 04/06 | 5001833354 | 716001 | | |
| Kerax | +/- | | 05/06 ▶ | 5001867491 | 716009 | | |
| Midlum | +/- | | 02/00 ▶ 04/06 | 5001833354 | 716001 | | |
| Midlum | +/- | | 05/06 ▶ | 5001867491 | 716009 | | |
| Premium | +/- | | 04/96 ▶ 04/06 | 5001833354 | 716001 | | |
| Premium | +/- | | 05/06 ▶ | 5001867491 | 716009 | | |
| SCANIA (BUS)  | | | | | | | |
| Omni | + | | 09/02 ▶ | 1100372B | 716049 | | |
| SCANIA TRUCKS  | | | | | | | |
| Serie 4 | +/- | prefilter | 10/96 ▶ 10/04 | 1326180 | 716040 | | |
| Serie 4 | +/- | | 10/95 ▶ 10/04 | 1420197 | 716039 | | |
| Serie P | +/- | prefilter | 09/04 ▶ | 1326180 | 716040 | | |
| Serie P | +/- | | 09/04 ▶ | 1420197 | 716039 | | |
| Serie R | +/- | prefilter | 06/04 ▶ | 1326180 | 716040 | | |
| Serie R | +/- | | 06/04 ▶ | 1420197 | 716039 | | |
| Serie T | +/- | prefilter | 09/04 ▶ 12/05 | 1326180 | 716040 | | |
| Serie T | +/- | | 09/04 ▶ 12/05 | 1420197 | 716039 | | |
| Serie P,G,R,T | +/- | | 10/07 ▶ | 1770813 | 716052 | | |
| VOLVO TRUCKS  | | | | | | | |
| F6 | +/- | | 10/87 ▶ 12/94 | 1584575 | 716045 | | |

|  | AC |  |  | PA    | CA    |
|---|-----|---|---|--|--|
| VOLVO TRUCKS  (.../...) | | | | | |
| F7 | +/- | | 08/78 ▶ 05/88 | 1584575 | 716045 |
| F10 | +/- | | 08/77 ▶ 12/94 | 1584575 | 716045 |
| F12 | +/- | | 08/77 ▶ 09/91 | 1584575 | 716045 |
| F12 | +/- | | 10/91 ▶ 12/94 | 8143691-7 | 716041 20409908 716053 |
| F16 | +/- | | 10/87 ▶ 12/94 | 1584575 | 716045 |
| FH | +/- | | 09/05 ▶ | 8143691-7 | 716041 20409908 716053 |
| FH12 | +/- | | 08/93 ▶ 12/05 | 8143691-7 | 716041 20409908 716053 |
| FH16 Serie | +/- | | 08/93 ▶ | 8143691-7 | 716041 20409908 716053 |
| FL | +/- | | 04/06 ▶ | 20559447 | 716009 |
| FL12 | +/- | | 09/95 ▶ 10/98 | 1584575 | 716045 |
| FM-Serie | +/- | | 09/05 ▶ | 8143691-7 | 716041 20409908 716053 |
| FM7-Serie | +/- | | 08/98 ▶ 02/08 | 8143691-7 | 716041 20409908 716053 |
| FM9-Serie | +/- | | 11/01 ▶ | 8143691-7 | 716041 20409908 716053 |
| FM10-Serie | +/- | | 08/98 ▶ | 8143691-7 | 716041 20409908 716053 |
| FM12-Serie | +/- | | 11/01 ▶ | 8143691-7 | 716041 20409908 716053 |
| FH II | +/- | | 01/13 ▶ | 82354791 | 716067• |
| FM/FMX II | +/- | | 01/13 ▶ | 82354791 | 716067• |
| FH II | +/- | | 01/13 ▶ | 82348995 | 716068• |
| FM/FMX II | +/- | | 01/13 ▶ | 82348995 | 716068• |
| FH II | +/- | | 01/13 ▶ | 82351184 | 716069• |
| FM/FMX II | +/- | | 01/13 ▶ | 82351184 | 716069• |



clim PUR™



clim SPRAY™



ROLL MEDIA

clim PUR™

Air conditioning cleaner

Nettoyant climatisation
Klimasystem-reiniger
Limpiador del climatizador
Limpador de ar condicionado
Air conditioning reiniger
Detergente climatizzazione
Środek czyszczący do klimatyzacji
Очиститель системы кондиционирования воздуха
Čistící prostředek pro klimatizace
Sredstvo za čišćenje klimatizacije
Klímaberendezés tisztító spray
Curăţitor de aer condiţionat
Klima temizleyici
ΚΑΘΑΡΙΣΤΙΚΟ ΚΛΙΜΑΤΙΣΤΙΚΟΥ



Valeo



716002

CLIM PUR'

1

clim SPRAY™

Cabin cleaner

Purifiant habitacle
Innenraum-luft-reiniger
Purificador de aire del habitáculo
Purificador do ar do habitáculo
Interieur verfrisser
Detergente abitacolo
Odświeżacz kabinowy
Очиститель воздуха
Čistič interiéru vozu
Čistač kabine vozila
Utastér légtisztító spray
Purificator habitaculu
Почистващ въздуха на купето препарат
Kabin hava temizleyicisi
ΚΑΘΑΡΙΣΤΙΚΟ ΚΑΜΠΙΝΑΣ



Valeo



716003

CLIM SPRAY

1

ROLL MEDIA



| Valeo | | i | Qty |
|---------------|---|----------|-----|
| 716051 | Height / Hauteur : 2 m Length / Longueur : 20 m Thickness / Largeur : 11 mm - 14 mm Diameter / Diamètre : 0.65 m Complete surface dimension / Dimension surface totale : 40 m ² | | 1 |



Bus universal filter roll media for interior and exterior air distribution

Rouleau de média filtrant universel pour bus, intérieur et extérieur

Bus universelles filter rollmittel für verteilung von innen- und außenluft

Rollo de material filtrante universal para autobus, distribución del aire interior y exterior

Rolo de material filtrante universal para autocarro, distribuição de ar interior e exterior

Rotolo filtro abitacolo a metro universale per bus per climatizzazione

Rol met universeel autobus filtermateriaal, interieur en exterior

Bus universalne zrolowane medium filtrujące

Автобус универсальный рулон со свернутым фильтром для фильтрации наружного и внутрисалонного воздуха

Univerzálny filtračný materiál pre autobusy, interné a externé rozvody vzduchu

Univerzální stočená filtrační tkanina pro autobusy, vnitřní i vnější přívody vzduchu

Univerzalni materijal za filtriranje, namijenjen za autobuse u unutrašnjoj i vanjskoj instalaciji zraka

Bus univerzális feltekerhető szűrő anyag külső és belső levegőszállításához

Rulou de material filtrant / filtru universal pentru distribuție de aer interior și exterior pentru bus

Otobüs üniversal filtre. Rulo malzeme. Diş hava ve dahili çevirim filtrelemesi

Διεθνές ρολό φίλτρου για λεωφορεία. Κατάλληλο για εσωτερική και εξωτερική χρήση, στο σύστημα εξαερισμού του οοχήματος.

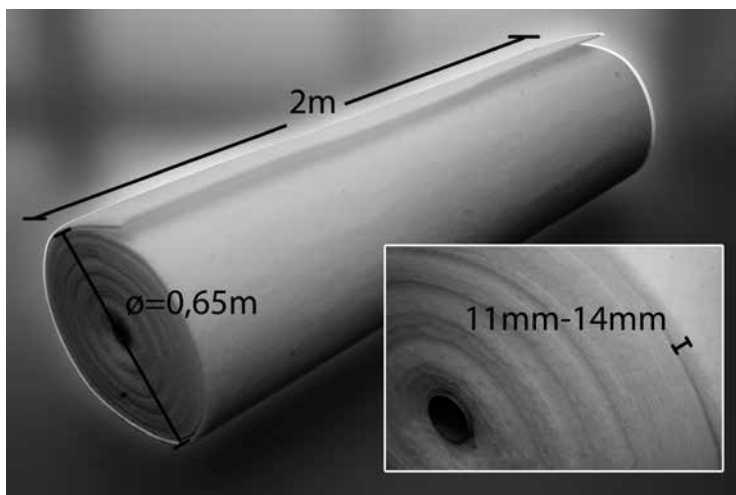



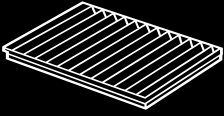

698840

PA  VT01

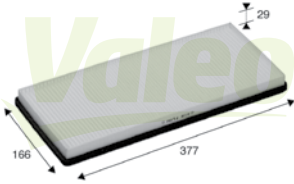

MERCEDES

Sprinter I

715595

PA  VT03

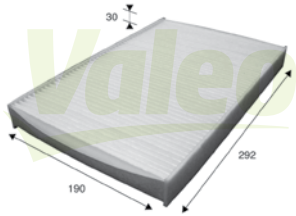

IVECO

Daily III

716000

PA  VT01

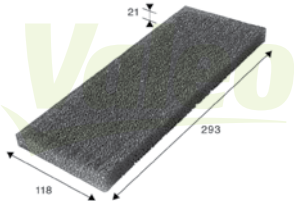

RENAULT TRUCKS

AE (Magnum)

716001

PA  VT01

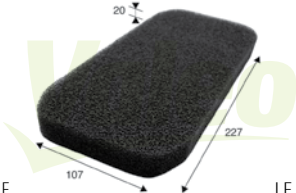

DAF
 DAF
 RENAULT TRUCKS
 RENAULT TRUCKS
 RENAULT TRUCKS

LF 45
 LF 55
 Kerax
 Midlum
 Premium

716004

PA  VT02

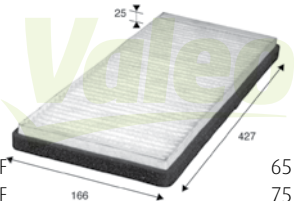

DAF
 DAF
 DAF
 DAF
 DAF

65 CF
 75 CF
 85 CF
 CF 65
 CF 75

716005

PA

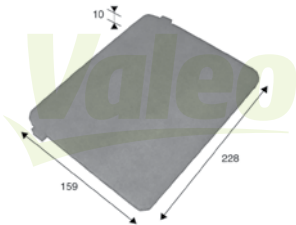

DAF

95 Serie

716006

PA  VT02

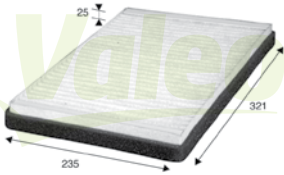

DAF
DAF
DAF

95 XF
XF 105
XF 95

716007

PA  VT02

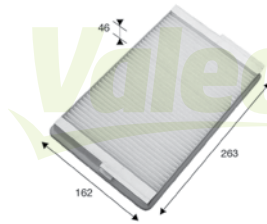

DAF

CF 85

716008

CA  VT02

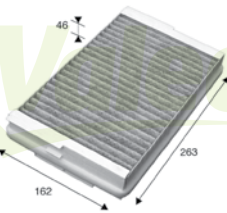

DAF

CF 85

716009

PA  VT01

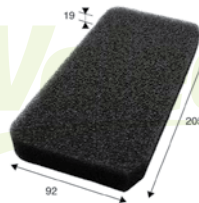

RENAULT TRUCKS
RENAULT TRUCKS
VOLVO TRUCKS

Midlum
Premium
FL

716010

PA  VT02

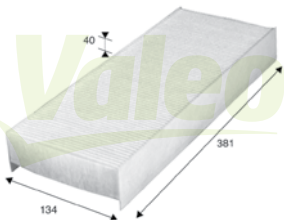

MERCEDES TRUCKS

Actros

716011

PA  VT02

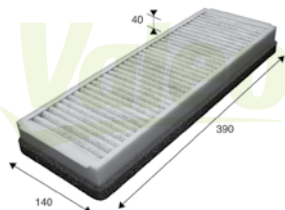

MERCEDES TRUCKS

Actros

716012

CA  VT05

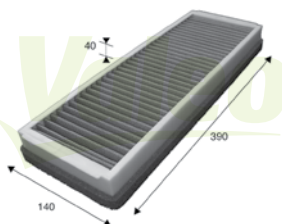

MERCEDES TRUCKS

Actros

716013

CA  VT02

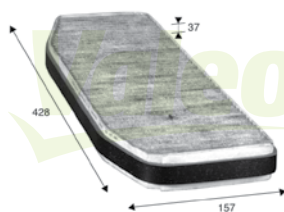

MERCEDES TRUCKS

Actros

716014

PA  VT02

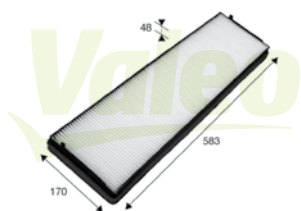

MERCEDES TRUCKS

Atego I

MERCEDES TRUCKS

Atego II

716015

CA  VT02

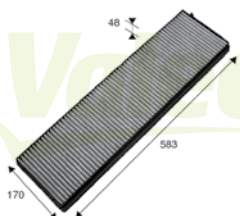

MERCEDES TRUCKS

Atego I

MERCEDES TRUCKS

Atego II

716016

PA

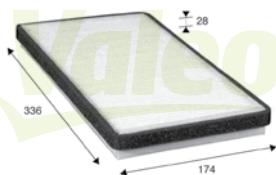

MERCEDES TRUCKS

MK Serie

MERCEDES TRUCKS

SK Serie

716017

PA  VT02

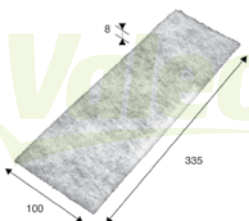

MERCEDES TRUCKS

Actros

716018

PA  VT02

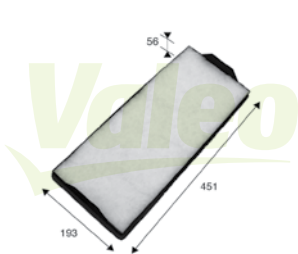

MERCEDES TRUCKS
MERCEDES TRUCKS

Axor I
Axor II

716019

PA  VT02

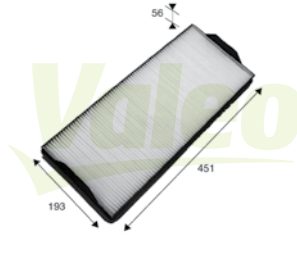

MERCEDES TRUCKS
MERCEDES TRUCKS
MERCEDES TRUCKS

Axor
Axor II
Econic (957)

716020

CA  VT02

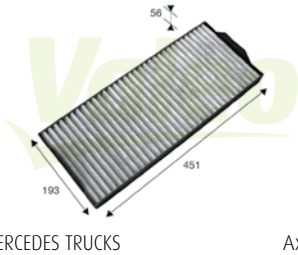

MERCEDES TRUCKS
MERCEDES TRUCKS
MERCEDES TRUCKS

Axor
Axor II
Econic (957)

716021

PA  VT02

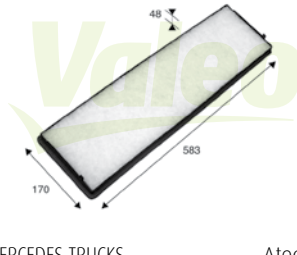

MERCEDES TRUCKS
MERCEDES TRUCKS

Atego I
Atego II

716023

CA  VT01

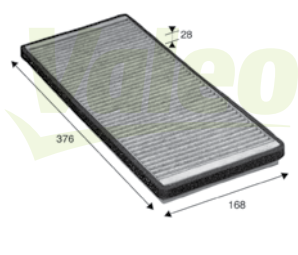

MERCEDES

Sprinter I

716028

PA  VT02

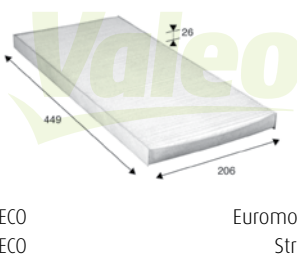

IVECO
IVECO
IVECO

Euromover
Stralis
Trakker

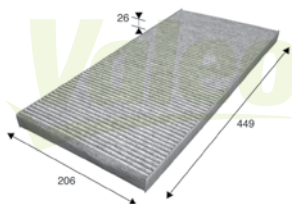
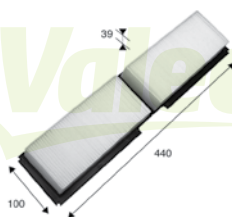
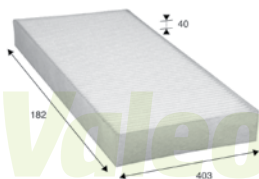
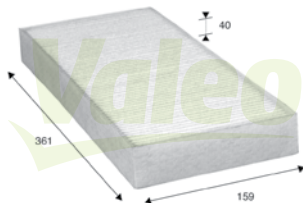
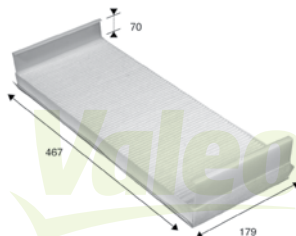
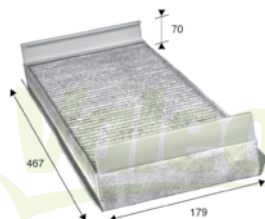
716029**CA**  VT02IVECO
IVECO
IVECOEuromover
Stralis
Trakker**716033****PA**  VT01IVECO
IVECO
IVECOEurostar
Eurotech
Eurotrakker**716034****PA**  VT02MAN (BUS)
MAN (BUS)
MAN TRUCKS
MAN TRUCKS
MAN TRUCKS
MAN TRUCKSLions Coach, Comfort
UEL313, UEL353
F2000, F2000 Evolution
FE Serie, LE Serie (250-280)
M2000, M2000 Evolution
ME Serie**716035****PA**  VT01MAN TRUCKS
MAN TRUCKS
MAN TRUCKSL2000, L2000 Evolution
LE Serie (110-220)
M2000, M2000 Evolution**716036****PA**  VT02MAN (BUS)
MAN TRUCKS
MAN TRUCKS
MAN TRUCKS
MAN TRUCKS
NEOPLANLions Regio
TGA
TGL
TGM
Trendliner**716037****CA**  VT02MAN (BUS)
MAN TRUCKS
MAN TRUCKS
MAN TRUCKS
MAN TRUCKS
NEOPLANLions Regio
TGA
TGL
TGM
Trendliner

716039**PA**  VT06

SCANIA TRUCKS
 SCANIA TRUCKS
 SCANIA TRUCKS
 SCANIA TRUCKS

Serie 4
 Serie P
 Serie R
 Serie T

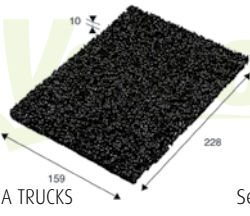
716040**PA**  VT06

SCANIA TRUCKS
 SCANIA TRUCKS
 SCANIA TRUCKS
 SCANIA TRUCKS

Serie 4
 Serie P
 Serie R
 Serie T

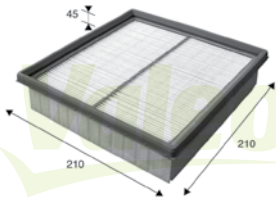
716041**PA**  VT02

VOLVO TRUCKS
 VOLVO TRUCKS
 VOLVO TRUCKS
 VOLVO TRUCKS

F12,FH,FH12,FH16 Serie
 FM12-Serie
 FM9-Serie,FM10-Serie
 FM-Serie,FM7-Serie

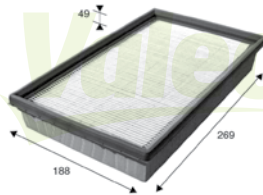
716045**PA**

VOLVO TRUCKS
 VOLVO TRUCKS
 VOLVO TRUCKS

F16
 F6,F7,F10,F12
 FL12

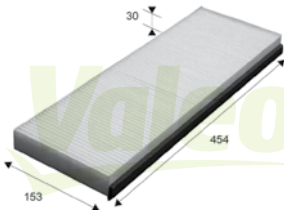
716046**PA**

MAN (BUS)
 MERCEDES (BUS)
 NEOPLAN
 NEOPLAN

Lions Coach
 O 550-Integro, S400
 Cityliner
 Starliner II

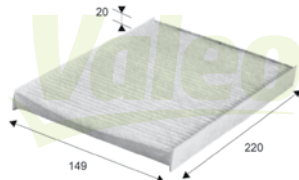
716047**PA**

MAN (BUS)
 NEOPLAN

Lions Series
 Centroliner, Tourliner

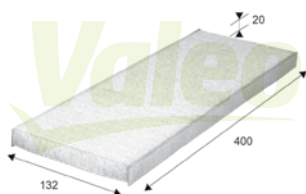
716048**PA**

MAN (BUS)
 MERCEDES (BUS)
 NEOPLAN

Lions Coach
 O 530 - Citaro
 Tourliner

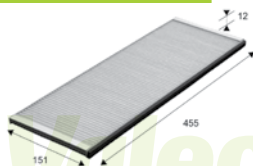
716049**PA**

IRISBUS Agora, Ares, Arway, Axer
 IRISBUS Citelis, CityClass, Evadys, Liliade H
 IRISBUS Midi GX, Midys, Moovy
 IVECO Bus Cavis, Euroclass, Euro Rider
 MAN (BUS) Lion's
 MERCEDES (BUS) Citaro LE, Conecto
 MERCEDES (BUS) Citaro, Travego, Setra S400
 NEOPLAN Centroliner
 SCANIA (BUS) Omni

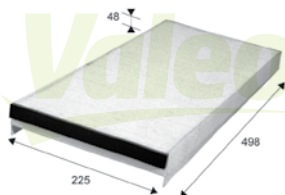
716050**PA**

MERCEDES (BUS)

O 530 - Citaro

716051

ROLL MEDIA

40m240m240m240m2

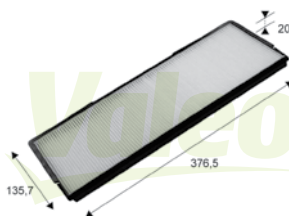
716052**PA**

SCANIA TRUCKS
 SCANIA TRUCKS
 SCANIA TRUCKS

G (G230-G480)
 P (P230 - P470)
 R (R230-R620)

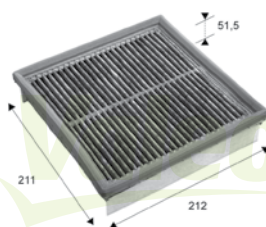
716053**CA**  VT02

VOLVO TRUCKS
 VOLVO TRUCKS
 VOLVO TRUCKS

F12, F16, FH,
 FH12, FH16-Serie
 FM10-Serie,
 FM12-Serie, FM7-Serie
 FM9-Serie, FM-Serie

716054

PA

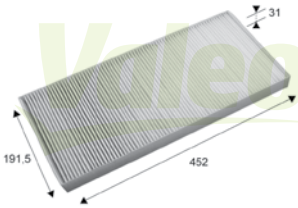

NEOPLAN (NEOMAN)

Transliner

716055

PA

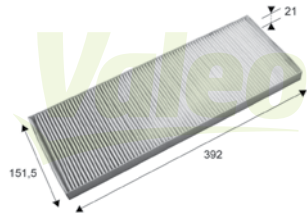

NEOPLAN (NEOMAN)

Starliner I

716056

PA

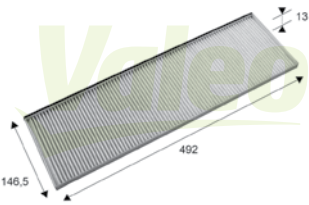

MAN (Bus)

Lions Series

MERCEDES (EVOBUS/SETRA)

O340, O350

NEOPLAN (NEOMAN)

Tourliner

716057

PA

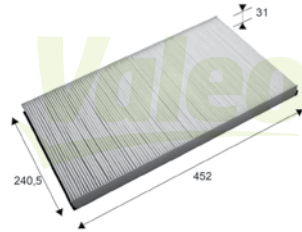

MAN (Bus)

NG, NL, NUE

NEOPLAN (NEOMAN)

Centroliner

716058

PA

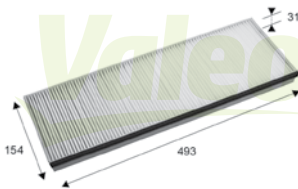

MERCEDES (EVOBUS/SETRA)

Class 400S

MERCEDES (EVOBUS/SETRA)

Comfort

MERCEDES (EVOBUS/SETRA) O 580, Travego

716059

PA

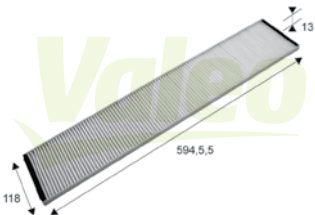

MERCEDES (EVOBUS/SETRA)

Setra S400

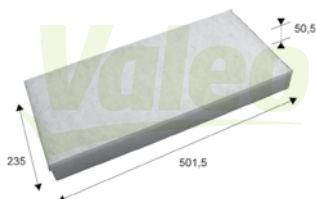
716060**PA**

MERCEDES (EVOBUS/SETRA) O 530 - Citaro

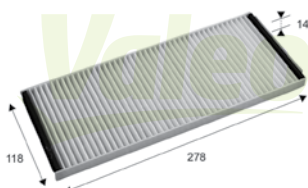
716061**PA**

MERCEDES (EVOBUS/SETRA) Setra S400

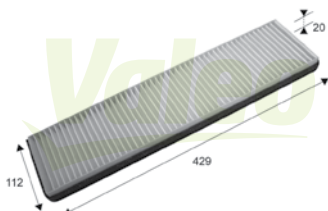
716062**PA**

IRISBUS

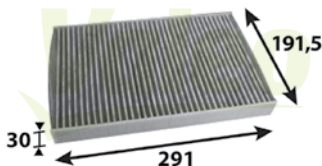
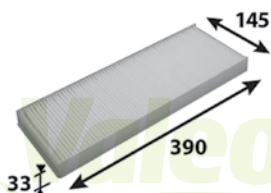
Agora, Citelis/ B, City Bus,
City Class**716063****CA**IRISBUS
IRISBUS
IVECODaily Citis, Recreo
Tourys, Way
Daily (2006>), Massif**716064****PA**

MAN (BUS) Lion's City
 MAN (BUS) NG, NL, NM, NUE
 MERCEDES (EVOBUS/SETRA) CapaCity (O 530GL/628)
 MERCEDES (EVOBUS/SETRA) Citaro O530, Integro (633)
 MERCEDES (EVOBUS/SETRA) Intercity (634), Intouro II (633)
 MERCEDES (EVOBUS/SETRA) Setra S400, Turismo II/M
 MERCEDES (EVOBUS/SETRA) Travego (O 580)

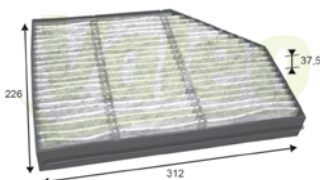
716065**CA**

MERCEDES TRUCKS

Actros II

716066

PA

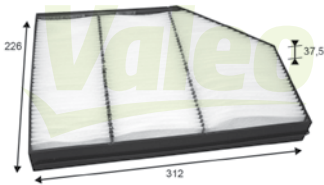

MERCEDES TRUCKS

Actros II

716067

PA



VOLVO TRUCKS

FH II
 FM/FMX II (New FM /
 FMX 2013-)FH II
 FM/FMX II (New FM /
 FMX 2013-)

716068

PA

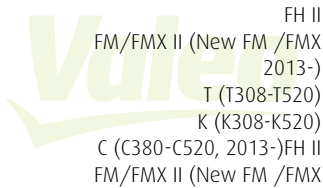

VOLVO TRUCKS

FH II
 FM/FMX II (New FM /FMX
 2013-)
 T (T308-T520)
 K (K308-K520)
 C (C380-C520, 2013-)FH II
 FM/FMX II (New FM /FMX
 2013-)
 T (T308-T520)
 K (K308-K520)
 C (C380-C520, 2013-)

716069

PA



VOLVO TRUCKS

FH II
 FM/FMX II (New FM /
 FMX 2013-)
 T (T308-T520)
 K (K308-K520)
 C (C380-C520, 2013-)



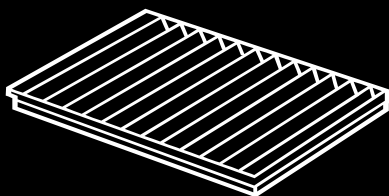
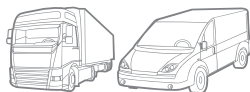

VT01

VT02

VT03

VT04

VT05

VT06



Fitting instructions number

Référence notice de montage

Nummer der Einbauanleitung

Referencia de la instrucción de montaje

Referência das intrucções de montagem

Numero di istruzioni di montaggio

Inbouw instructie nummer

Instrukcja montazu nr

Номер на инструкция за монтаж

Císlo montážního postupu

Beszerezési útmutató sorszáma

Broj instrukcije montaže

Montaj talimatname numarasi

Αριθμός οδηγιών τοποθέτησης



Valeo

VT01

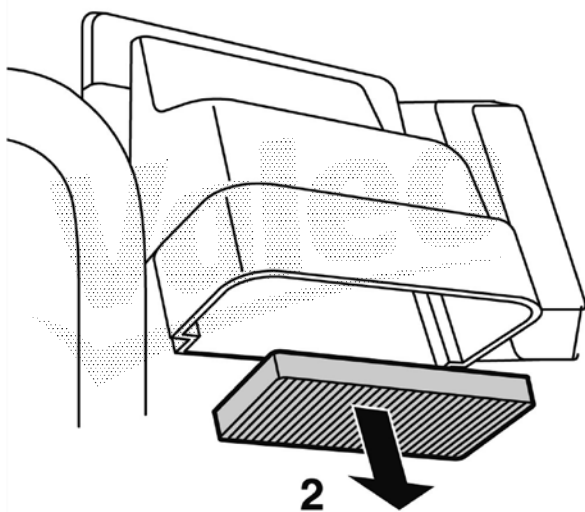
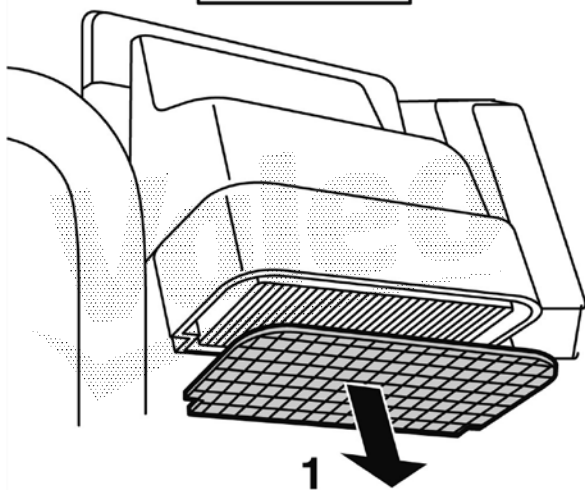

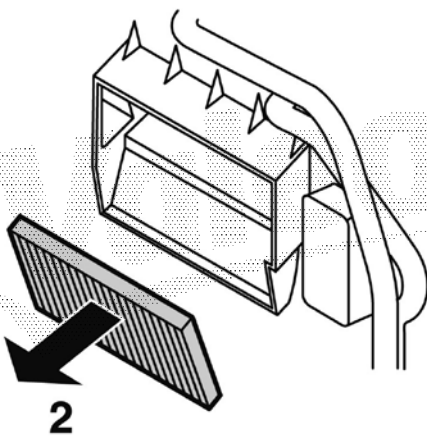
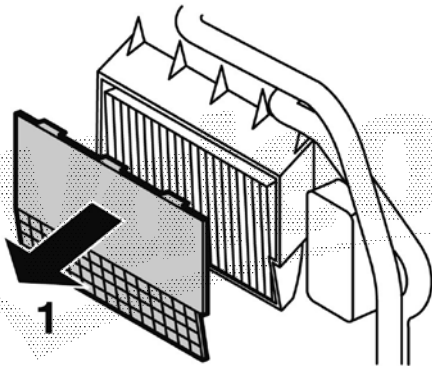



Valeo

VT03

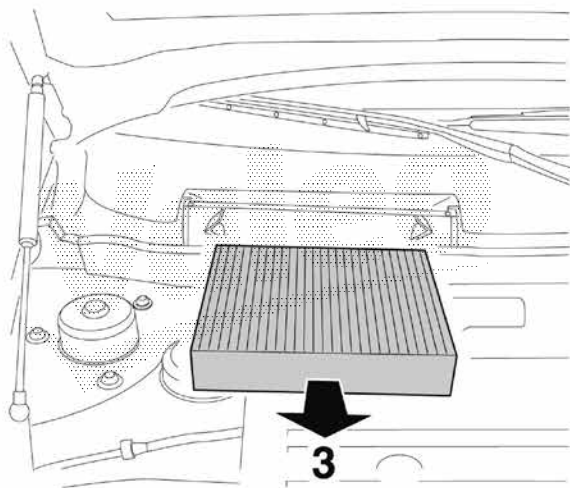
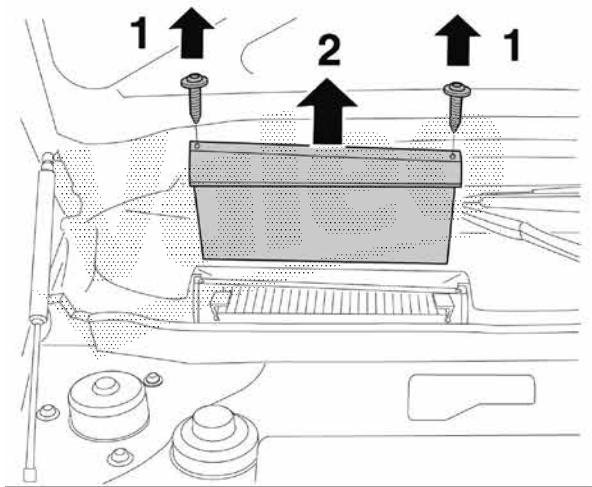
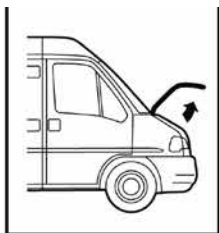

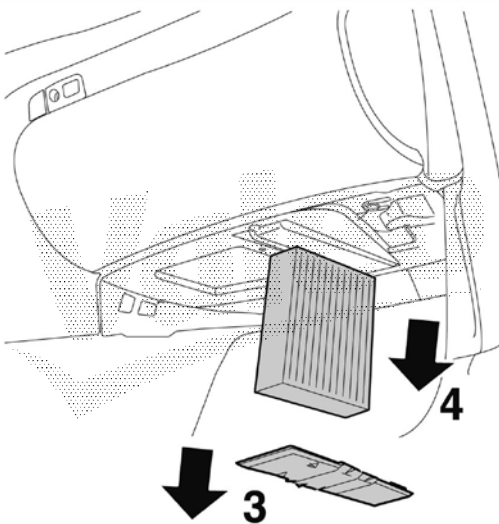
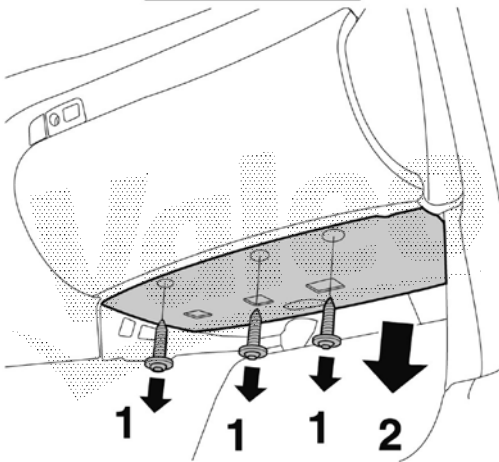
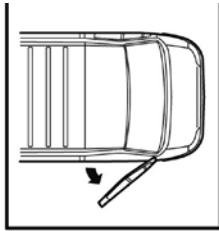



Valeo

VT05

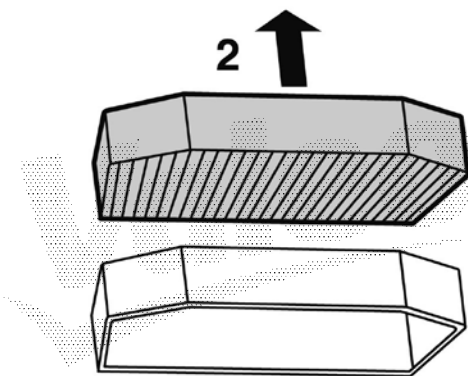
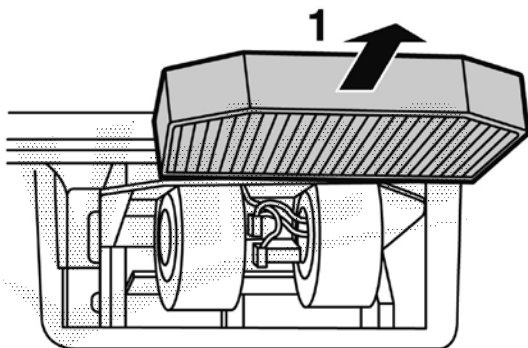
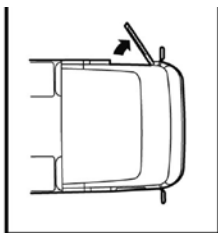

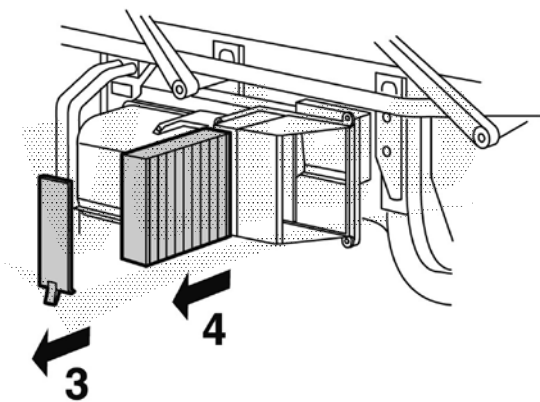
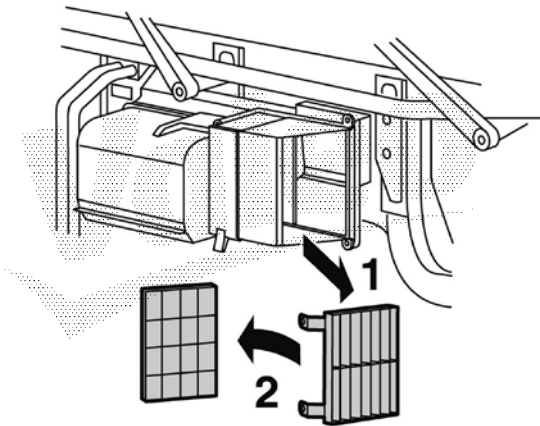



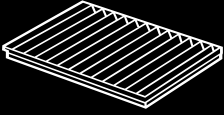





Valeo









Valeo









Valeo

|  |  |  |  |
|---|---|---|---|
| 698840 | PA | 9018300518 | MERCEDES Sprinter I |
| 715595 | PA | 3802821 | IVECO Daily III |
| 716000 | PA | 5001829129 | RENAULT TRUCKS AE (Magnum) |
| 716001 | PA | 1600428 | DAF LF 45 |
| | | 5001833354 | RENAULT TRUCKS LF 55 Kerax Midlum Premium |
| 716004 | PA | 1347066 | DAF 65 CF CF 65 75 CF CF 75 85 CF |
| 716005 | PA | 1347068 | DAF 95 Serie |
| 716006 | PA | 1658991 | DAF 95 XF XF 95 XF 105 |
| 716007 | PA | 1362124 | DAF CF 85 |
| 716008 | CA | 1362168 | DAF CF 85 |
| 716009 | PA | 5001867491 | RENAULT TRUCKS Midlum Premium |
| | | 20559447 | VOLVO TRUCKS FL |
| 716010 | PA | 8301118 | MERCEDES TRUCKS Actros |
| 716011 | PA | 8301218 | MERCEDES TRUCKS Actros |
| 716012 | CA | 8301318 | MERCEDES TRUCKS Actros |
| 716013 | CA | 8301518 | MERCEDES TRUCKS Actros |
| 716014 | PA | 9738350147 | MERCEDES TRUCKS Atego I Atego II |
| 716015 | CA | 9738350347 | MERCEDES TRUCKS Atego I Atego II |
| 716016 | PA | 8356947 | MERCEDES TRUCKS MK Serie SK Serie |
| 716017 | PA | 18350747 | MERCEDES TRUCKS Actros |
| 716018 | PA | 9408350247 | MERCEDES TRUCKS Axor I Axor II |
| 716019 | PA | 9408350047 | MERCEDES TRUCKS Axor Axor II Econic (957) |
| 716020 | CA | 9408350147 | MERCEDES TRUCKS Axor Axor II Econic (957) |
| 716021 | PA | 9738350247 | MERCEDES TRUCKS Atego I Atego II |
| 716023 | CA | 9018300418 | MERCEDES Sprinter I |
| 716028 | PA | 504024890 | IVECO Euromover |

| Valeo |  |  |  |
|-------------------------|---|---|---|
| 716028 (.../...) | PA | 504024890 | IVECO Stralis Trakker |
| 716029 | CA | 2994583 | IVECO Euromover Stralis Trakker |
| 716033 | PA | 500387947 | IVECO Eurostar Eurotech Eurotrakker |
| 716034 | PA | 81619100011 | MAN TRUCKS F2000, F2000 Evolution FE Serie LE Serie (250-280) M2000, M2000 Evolution ME Serie MAN (BUS) Lions Coach Lions Comfort UEL-313 UEL-353 |
| 716035 | PA | 85619500025 | MAN TRUCKS L2000, L2000 Evolution LE Serie (110-220) M2000, M2000 Evolution |
| 716036 | PA | 81619100018 | MAN TRUCKS TGA TGL TGM MAN (BUS) NEOPLAN (NEOMAN) Lions Regio Trendliner |
| 716037 | CA | 81619100019 | MAN TRUCKS TGA TGL TGM MAN (BUS) NEOPLAN (NEOMAN) Lions Regio Trendliner |
| 716039 | PA | 1420197 | SCANIA TRUCKS Serie 4 Serie P Serie R Serie T |
| 716040 | PA | 1326180 | SCANIA TRUCKS Serie 4 Serie P Serie R Serie T |
| 716041 | PA | 8143691-7 | VOLVO TRUCKS F12 FH FH12 FH16 Serie FM-Serie FM7-Serie FM9-Serie |
| | | | |

|  |  |  |  |
|---|---|--|---|
| 716041 (.../...) | PA | 8143691-7 | VOLVO TRUCKS FM10-Serie FM12-Serie |
| 716045 | PA | 1584575 | VOLVO TRUCKS F6 F7 F10 F12 F16 FL12 |
| 716046 | PA | 18357047 A0018357047 18357047 1101891A 1101891B | MAN (BUS) MERCEDES (EVOBUS/SETRA) Lions Coach O 550 - Integro O 550 - Integro M S400 Serie NEOPLAN (NEOMAN) Cityliner Starliner II |
| 716047 | PA | 88779100003 | MAN (BUS) NEOPLAN (NEOMAN) Lions Series Centroliner Tourliner |
| 716048 | PA | 88779100002 H14002499 88779100002 | MAN (BUS) MERCEDES (EVOBUS/SETRA) NEOPLAN (NEOMAN) Lions Coach O 530 - Citaro Tourliner |
| 716049 | PA | 1100372A 1101193 1100372A 1101193A 1100372A 1101193A 1100372A 93350A 81779100016 6278350447 20401236 18255447 1100372B | IRISBUS Agora Ares Anway Aver Citelis CityClass Evadys Liliade H Midi GX Midys Moovy IVECO Bus Civis Euroclass Euro Rider Lion's MERCEDES (EVOBUS/SETRA) Citaro K (628) Citaro LE O 345 - Conecto O 530 - Citaro O 580 - Travego Setra S400 NEOPLAN (NEOMAN) SCANIA (BUS) Centroliner Omni |
| 716050 | PA | 18351547 | MERCEDES (EVOBUS/SETRA) O 530 - Citaro |
| 716051 | | | ROLL MEDIA 40m240m240m240m2 |

|  |  PA  |  |    |
|---|--|---|--|
| 716052 | PA | 1770813 | SCANIA TRUCKS G (G230-G480) P (P230- P470) R (R230-R620) |
| 716053 | CA | 20409908 | VOLVO TRUCKS F12, F16, FH, FH12, FH16-Serie FM10-Serie, FM12-Serie, FM7-Serie FM9-Serie, FM-Serie |
| 716054 | PA | 180740200 | Neoplan (Neoman) Transliner |
| 716055 | PA | 180412710 | Neoplan (Neoman) Starliner I |
| 716056 | PA | 18355547 | MAN (Bus) Lions Series MERCEDES (EVOBUS/SETRA) O340, O350 NEOPLAN (NEOMAN) Tourliner |
| 716057 | PA | 81779720155 81779100012 | MAN (Bus) NG, NL, NUE NEOPLAN (NEOMAN) Centroliner |
| 716058 | PA | 18357147 | MERCEDES (Evobus/Setra) Comfort Class 400S O 580 - Travego |
| 716059 | PA | 18356147 | MERCEDES (Evobus/Setra) Setra S400 Top Class |
| 716060 | PA | 18359147 | MERCEDES (Evobus/Setra) O 530 - Citaro |
| 716061 | PA | 18356247 | MERCEDES (Evobus/Setra) Setra S400 Top Class |
| 716062 | PA | 5006175605 | IRISBUS Agora Citelis/ B City Bus City Class |
| 716063 | CA | 2994769 | IRISBUS Daily Citis, Recreo Tourys, Way IVECO Campagnola, Daily V Massif, Rapido |
| 716064 | PA | 18359247 18359248 18359249 18359250 18359247 18359250 | KING LONG BUSES XMQ MAN (BUS) Lion's City G/GL/GLX Lion's City LL (NL-Serie) Lion's City M (NM-Serie) Lion's City UELL MERCEDES (EVOBUS/SETRA) CapaCity (O 530GL/628) Citaro O530, Integro (633) Intercity (634) Intouro II (633) Setra S400 Tourismo II/M Travego (O 580) NEOPLAN (NEOMAN) Cityliner C/HC/HDC/HDL VISEON BUS C-Serie |
| 716065 | CA | 9608300118 | MERCEDES TRUCKS Actros II |
| 716066 | PA | 9608300018 | MERCEDES TRUCKS Actros II |
| 716067 | PA | 82354791 | VOLVO TRUCKS FH II FM/FMX II (New FM /FMX 2013-) |
| 716068 | PA | 82348995 | VOLVO TRUCKS FH II FM/FMX II (New FM /FMX 2013-) T (T308-T320) K (K308-K520) C (C380-C520, 2013-) |

Valeo

716069

PA

82351184

VOLVO TRUCKS

FH II FM/FMX II (New FM /FMX 2013-)
T (T308-T520) K (K308-K520) C
(C380-C520, 2013-)



|  | Valeo |
|---|--------------|
| DAF | |
| 1322255 | 716006 |
| 1322259 | 716004 |
| 1347066 | 716004 |
| 1347068 | 716005 |
| 1362124 | 716007 |
| 1362168 | 716008 |
| 1600428 | 716001 |
| 1658991 | 716006 |
| 1659691 | 716004 |
| IRISBUS | |
| 93350A | 716049 |
| 1100372A | 716049 |
| 1101193 | 716049 |
| 1101193A | 716049 |
| 2994769 | 716063 |
| 5006175605 | 716062 |
| IVECO | |
| 2994583 | 716029 |
| 2994769 | 716063 |
| 2995964 | 716028 |
| 3799020 | 716033 |
| 3802821 | 715595 |
| 93162385 | 716033 |
| 500387947 | 716033 |
| 504024890 | 716028 |
| 9000709A | 716028 |
| IVECO Bus | |
| 1100372A | 716049 |
| 1101193 | 716049 |
| 1101193A | 716049 |
| 93350A | 716049 |
| 50006175605 | 716049 |
| KING LONG BUSES | |
| H14003495 | 716064 |
| MAN TRUCKS | |
| 81619100011 | 716034 |
| 81619100018 | 716036 |
| 81619100019 | 716037 |
| 85619500025 | 716035 |
| MAN (BUS) | |
| 0018355547 | 716056 |
| A0018357047 | 716046 |
| 1101891A | 716046 |

|  | Valeo |
|---|--------------|
| MAN (BUS) (.../...) | |
| 1101891B | 716046 |
| 18357047 | 716046 |
| 81619100011 | 716034 |
| 81619100018 | 716036 |
| 81619100019 | 716037 |
| 81779100012 | 716057 |
| 81779100016 | 716049 |
| 81779720148 | 716049 |
| 81779720155 | 716057 |
| 83779720656 | 716064 |
| 88779100002 | 716048 |
| 88779100003 | 716047 |
| MERCEDES | |
| 9018300418 | 716023 |
| 9018300018 | 698840 |
| 9018300518 | 698840 |
| 0008303318 | 698840 |
| MERCEDES TRUCKS | |
| 0008301118 | 716010 |
| 0008301218 | 716011 |
| 0008301518 | 716013 |
| 0008356947 | 716016 |
| 9408350047 | 716019 |
| 9408350147 | 716020 |
| 9408350247 | 716018 |
| 9608300018 | 716066 |
| 9608300118 | 716065 |
| 9738350147 | 716014 |
| 9738350247 | 716021 |
| 9738350347 | 716015 |
| 0008303418 | 716012 |
| 0008301318 | 716012 |
| 0018350747 | 716017 |
| 0008358947 | 716017 |
| A9408350047 | 716019 |
| A9408350147 | 716020 |
| A9408350247 | 716018 |
| A9738350247 | 716021 |
| B67582415 | 716018 |
| MERCEDES (EVOBUS/SETRA) | |
| 0018255447 | 716049 |
| 0018351547 | 716050 |

|  | Valeo |
|---|--------------|
| MERCEDES (EVOBUS/SETRA) (.../...) | |
| 0018352747 | 716048 |
| 0018355447 | 716049 |
| 0018355547 | 716056 |
| 0018356147 | 716059 |
| 0018356247 | 716061 |
| 0018357047 | 716046 |
| 0018357147 | 716058 |
| 0018359147 | 716060 |
| 0018359247 | 716064 |
| H14002499 | 716048 |
| H14002484 | 716050 |
| H14003495 | 716064 |
| 1101891A | 716046 |
| 1101891B | 716046 |
| 20401236 | 716049 |
| 6278350447 | 716049 |
| 88779100002 | 716048 |
| NEOPLAN (NEOMAN) | |
| 0018355547 | 716056 |
| 0018357047 | 716046 |
| 0018359247 | 716064 |
| 1101891A | 716046 |
| 1101891B | 716046 |
| 180412710 | 716055 |
| 180740200 | 716054 |
| 18255447 | 716049 |
| 18355447 | 716049 |
| 18357047 | 716046 |
| 20401236 | 716049 |
| 6278350447 | 716049 |
| 81619100018 | 716036 |
| 81619100019 | 716037 |
| 88779100002 | 716048 |
| 88779100003 | 716047 |
| 81779100012 | 716057 |
| RENAULT TRUCKS | |
| 5001829129 | 716000 |
| 5001833354 | 716001 |
| 5001844054 | 716000 |
| 5001867491 | 716009 |

**Valeo****SCANIA TRUCKS**

| | |
|---------|--------|
| 1326180 | 716040 |
| 1420197 | 716039 |
| 1770813 | 716052 |

SCANIA (BUS)

| | |
|----------|--------|
| 1100372A | 716049 |
| 1100372B | 716049 |

WISEON BUS

| | |
|-----------|--------|
| H14003495 | 716064 |
|-----------|--------|

VOLVO TRUCKS

| | |
|-----------|--------|
| 8143691-7 | 716041 |
| 20409908 | 716053 |
| 20559447 | 716009 |
| 4771477 | 716041 |
| 8143691 | 716045 |
| 8144430 | 716045 |
| 11007388 | 716041 |
| 110073889 | 716041 |
| 1584575 | 716045 |

Volvo (Bus/Trucks)

| | |
|----------|--------|
| 82354791 | 716067 |
| 82348995 | 716068 |
| 82351184 | 716069 |

**Valeo****BALDWIN**

| | |
|--------|--------|
| PA3980 | 716034 |
| PA4612 | 716006 |
| PA4928 | 716004 |
| PA4938 | 716039 |
| PA4945 | 716019 |
| PA4947 | 716033 |
| PA4955 | 716036 |
| PA5330 | 716001 |
| PA5336 | 716028 |
| PA5339 | 716035 |
| PA5340 | 716014 |
| PA5341 | 716007 |
| PA9812 | 716010 |

CORTECO

| | |
|----------|--------|
| 21651973 | 716034 |
| 21651976 | 698840 |
| 21651977 | 716010 |
| 21652002 | 716018 |
| 21652997 | 716007 |
| 21652998 | 716014 |
| 21652999 | 716015 |
| 21653000 | 716020 |
| 21653001 | 716021 |
| 21653003 | 716012 |
| 21653005 | 716036 |
| 21653006 | 716011 |
| 21653007 | 716019 |
| 21653016 | 716035 |
| 21653018 | 716047 |
| 21653019 | 716016 |
| 21653021 | 716004 |
| 80000633 | 716041 |
| 80000076 | 716048 |
| 80000333 | 716028 |
| 80000336 | 716049 |
| 80000337 | 716050 |
| 80000349 | 716017 |
| 80000350 | 716040 |
| 80000354 | 716005 |
| 80000362 | 716039 |
| 80000364 | 716037 |
| 80000623 | 716006 |
| 80000626 | 716008 |

**Valeo****CORTECO (.../...)**

| | |
|----------|--------|
| 80000631 | 716046 |
| 80000641 | 716046 |
| 80000645 | 716001 |
| 80000916 | 716063 |

KNECHT/MAHLE

| | |
|--------|--------|
| LA42/1 | 716010 |
| LA43 | 716012 |
| LA50 | 716006 |
| LA55 | 716004 |
| LA67 | 716034 |
| LA71 | 716007 |
| LA83 | 698840 |
| LA85 | 716014 |
| LA148 | 716041 |
| LA154 | 716036 |
| LA170 | 716028 |
| LA198 | 716033 |
| LA279 | 716035 |
| LA355 | 716049 |
| LA357 | 716050 |
| LA358 | 716019 |
| LAK43 | 716011 |
| LAK85 | 716015 |
| LAK154 | 716037 |

MANN HUMMEL

| | |
|---------|--------|
| CU1722 | 716039 |
| CU2101 | 716009 |
| CU2184 | 716041 |
| CU2218 | 716047 |
| CU2303 | 716001 |
| CU2304 | 716040 |
| CU2534 | 716007 |
| CU2785 | 716045 |
| CU3001 | 716000 |
| CU3132 | 716006 |
| CU32001 | 716066 |
| CU3423 | 716016 |
| CU37230 | 716035 |
| CU3855 | 716012 |
| CU3858 | 698840 |
| CU3869 | 716010 |
| CU3959 | 716064 |
| CU4036 | 716048 |

**Valeo****MANN HUMMEL (.../...)**

| | |
|----------|--------|
| CU40110 | 716034 |
| CU4228 | 716004 |
| CU4408 | 716018 |
| CU4466 | 716033 |
| CU4469 | 716019 |
| CU4594 | 716028 |
| CU4627 | 716049 |
| CU4662 | 716046 |
| CU4795 | 716036 |
| CU5096 | 716050 |
| CU5809 | 716021 |
| CU5877 | 716014 |
| CUK2534 | 716008 |
| CUK2952 | 716063 |
| CUK32001 | 716065 |
| CUK3823 | 716011 |
| CUK3858 | 716023 |
| CUK4252 | 716013 |
| CUK4469 | 716020 |
| CUK4594 | 716029 |
| CUK4795 | 716037 |
| CUK5877 | 716015 |









Every effort has been made to ensure that the information contained in this catalogue is correct at the time of printing, but no warranty or representation is given or made as to the accuracy of such information and Valeo Service UK Ltd does not accept any liability whatsoever for any inaccuracies.

Valeo Service UK Ltd reserves the right to alter specifications and/or the final construction of products without notice.

Product references referred to in this catalogue may not be available in all countries.

All orders for products are only accepted subject to the terms and conditions of Valeo Service UK Ltd.

Photographs and drawings are not binding on Valeo Service UK Ltd. The copyright in this publication belongs to Valeo Service UK Ltd exclusively. No part of this publication may be reproduced by any means without the prior authorisation of Valeo Service UK Ltd.

L'affectation et la préconisation des produits figurant dans nos catalogues prennent en compte l'état du parc automobile au jour de leur parution.

La responsabilité de Valeo Service ne saurait être engagée en cas de modification, substitution ou suppression des affectations ou préconisations qui pourraient intervenir notamment à l'initiative des constructeurs de véhicules.

Les caractéristiques techniques de nos produits sont susceptibles d'évoluer à tout moment pour tenir compte des améliorations techniques

et technologiques.

Certaines références peuvent ne pas être disponibles dans tous les pays.

Les commandes sont régies par les conditions générales de vente de Valeo Service.

Photos et dessins non contractuels. La reproduction de tout ou partie de cette publication est interdite sans l'autorisation expresse et écrite de Valeo Service.

La aplicación de los productos sobre vehículos y las especificaciones de los productos que figuran en nuestros catálogos se refieren a la situación del parque de automóviles en la fecha de puesta en circulación de los productos.

Valeo Service España SA no asume ninguna responsabilidad en caso de modificación, sustitución o supresión de dichas aplicaciones y/o especificaciones que pudieran producirse por iniciativa de los fabricantes de automóviles.

Las características técnicas de nuestros productos son susceptibles de evolucionar en cualquier momento para incorporar las mejoras técnicas y tecnológicas que se desarrollen.

Las referencias de productos mencionadas en este catálogo puede que no estén disponibles en todos los países.

Los pedidos se regiran por las condiciones generales de venta de Valeo Service España SA.

Las fotografías y dibujos que aparecen en nuestros catálogos son meramente indicativas, por lo que no siempre coinciden exactamente con la apariencia externa de nuestros productos. Se prohíbe la reproducción de todo o parte de esta publicación sin la autorización expresa y escrita de Valeo Service España SA.

As prescrições e recomendações relativas ao uso ou utilidade dos produtos constantes de nossos catálogos levam em consideração o estado do parque automotivo à época do lançamento desses produtos.

A Valeo Sistemas Automotivos Ltda (Valeo Cibié Service) não será responsável por quaisquer modificações, substituições ou supressões incidentes sobre as prescrições e recomendações relativas ao uso ou utilidade de nossos produtos, que sejam decorrentes de ações dos construtores de veículos.

As características técnicas de nossos produtos são suscetíveis de alteração a qualquer momento para que sejam incorporadas melhorias técnicas e/ou tecnológicas.

Certas referências podem não estar disponíveis em todos os países.

Os pedidos feitos pelos clientes são regidos pelas condições gerais de venda da Valeo Sistemas Automotivos Ltda (Valeo Cibié Service).

Fotos e desenhos não contratuais. A reprodução do todo ou de parte desta publicação é proibida sem a autorização expressa e por escrito da Valeo Sistemas Automotivos Ltda (Valeo Cibié Service).

Le applicazioni e le specifiche dei prodotti che figurano nei nostri cataloghi si riferiscono alla situazione del parco circolante al momento della pubblicazione.

Valeo Service Italia S.p.A. declina qualsiasi responsabilità in caso di modifica, sostituzione o soppressione di applicazioni o specifiche eventualmente apporrate, senza preavviso, da parte dei Costruttori.

Le caratteristiche tecniche dei nostri prodotti sono suscettibili di modifiche in qualsiasi momento, per apportare migliorie tecniche e tecnologiche.

Alcuni riferimenti presenti in questo catalogo non sono disponibili in tutti i paesi.

Gli ordini sono regolamentati dalle condizioni generali di vendita di Valeo Service Italia S.p.A.

Le Foto ed i disegni che appaiono nel catalogo sono puramente indicativi. E' vietata la riproduzione della totalità o di una parte della presente pubblicazione senza un'esplicita autorizzazione scritta da parte di Valeo Service Italia S.p.A.

De ter zake van de producten in onze catalogi aangegeven bestemmingen en gedane aanbevelingen zijn gebaseerd op het wagenpark ten tijde van publicatie.

Valeo Service Benelux B.V. sluit elke aansprakelijkheid uit met betrekking tot wijziging, vervanging of annulering van de bestemmingen of aanbevelingen, die met name op initiatief van de autofabrikanten kunnen worden doorgevoerd.

De technische eigenschappen van onze producten kunnen te allen tijde evolueren teneinde rekening te houden met technische en technologische verbeteringen.

Bepaalde artikelen kunnen in bepaalde landen niet beschikbaar zijn.

Orders zijn onderworpen aan de algemene verkoopvoorwaarden van Valeo Service Benelux B.V.

Foto's en tekeningen zijn niet bindend.

De gehele of gedeeltelijke veeleevoudiging van deze uitgave zonder uitdrukkelijke voorafgaande schriftelijke toestemming van Valeo Service Benelux B.V. is verboden.

Die Verwendungsempfehlungen zu den in diesem Katalog aufgeführten Produkten beziehen sich auf den zum Zeitpunkt des Erscheinens des Katalogs existierenden Fahrzeugbestand.

Die Valeo Service Deutschland GmbH übernimmt keine Haftung für Änderungen, Ersetzungen oder Streichungen der Fahrzeuganwendung oder - Empfehlungen durch die Fahrzeughersteller.

Die technischen Eigenschaften unserer Produkte werden kontinuierlich weiterentwickelt, um einen hohen technologischen Standard zu gewährleisten.

Die Fotos oder Zeichnungen in diesem Katalog dienen ausschließlich zur Veranschaulichung unserer Produkte. Rechtliche Ansprüche können daraus nicht abgeleitet werden.

Einige Produktreferenzen sind nicht in allen Ländern verfügbar.

Lieferungen unterliegen den allgemeinen Geschäftsbedingungen der Valeo Service Deutschland GmbH.

Die Vervielfältigung dieses Katalogs oder Teilen daraus ist ohne schriftliches Einverständnis der Valeo Service Deutschland GmbH rechtlich nicht gestattet.

Przeznaczenie i zalecenia dotyczące produktów figurujących w naszych katalogach biorą pod uwagę stan parku samochodowego w dniu ich wprowadzenia na rynek.

Spółka "Valeo Service Eastern Europe Sp.zo.o." nie może być ponosić odpowiedzialności w przypadku zmiany, zastąpienia lub usunięcia wskazówek dotyczących przeznaczenia i zaleceń, które mogą wystąpić z inicjatywy producentów samochodów.

Dane techniczne naszych produktów mogą być w każdej chwili zmienione w celu uwzględnienia ulepszeń technicznych i technologicznych.

Niektóre modele mogą być niedostępne w niektórych krajach.

Zamówienia podlegają ogólnym warunkom umów "Valeo Service Eastern Europe Sp.zo.o."

Wykorzystywanie w całości lub w części zdjęć i rysunków zamieszczonych w naszych katalogach wymaga pisemnej zgody "Valeo Service Eastern Europe Sp.zo.o."

Kataloglarımızda yer alan ürünlerin kullanımı ve tanımları, otomobil parkının yaygın tarihindeki durumuna göredir.

Valeo Otomotiv Dağıtım AS, özellikle araç, üreticilerinin inisiyatifini sonucu yapılan değişiklik, ikame veya kaldırılmaldan sorumlu tutulamaz.

Ürünlerimiz teknik özellikleri, teknik ve teknolojik gelişmelerle paralel olarak geliştirilebilir.

Bazı referanslar bazı ülkelerde bulunmayabilir.

Siparişler, Valeo Otomotiv Dağıtım AS'un genel satış koşullarına uygun olarak ödenir.

Fotoğraf ve resimler akdi değildir. İşbu yayının Valeo Otomotiv Dağıtım AS'un önceden verilmiş yazılı izni olmaksızın kısmen veya tamamen çoğaltılması yasaktır.

Učinili jsme všechny kroky nezbytné k tomu, aby informace v tomto dokumentu byly přesné ke dni jeho tisku. Valeo Service Export nezodpovídá za případné neúplné či chybné informace zde uvedené.

Valeo Service Export si vyhrazuje právo úpravy specifikace a / nebo konečné formy výrobku bez předchozího upozornění.

Katalogová čísla obsažená v tomto katalogu nemusí být dostupná k prodeji na všech trzích. Konečné objednání výrobků se řídí obchodními podmínkami Valeo Service Export.

Fotografie a technické nákresy nezávisí na Valeo Service Export. Copyright je exklusivně Valeo Service Export. Žádná část tohoto katalogu nesmí být kopírována bez autorizace Valeo Service Export.

A VALEO teljes tudásával arra törekszik, hogy a katalógusban szereplő adatok műszaki tartalma teljesen korrekt legyen, ezért a VALEO SERVICE EXPORT nem vállal garanciát azok helyességéért, pontatlanságáért és nem terheli felelősség az esetleges hibákól erdő károkért.

A VALEO SERVICE EXPORT fenntartja a jogot a termékváltoztatásokra nélkülelt termékinformáció nélkül.

A katalógusban szereplő cikkszámok között előfordulhatnak olyanok is, melyek nem minden országban kerülnek forgalomba.

Minden termék rendelés a VALEO SERVICE EXPORT szerződéses kondíciói alapján érvényes.

A katalógusban szereplő fényképek és rajzok nem a VALEO SERVICE EXPORT készítményei. A szerzői jogok a VALEO SERVICE EXPORT kizárólagos tulajdonát képezik.

A kiadvány részét nem képező reprodukciókhoz nem szükséges a VALEO SERVICE EXPORT engedélye.

Назначение и рекомендации по эксплуатации продукции, содержащиеся в наших каталогах, указываются с учетом состояния автомобильного парка на день ее появления.

Компания «Valeo Service Eastern Europe Sp.zo.o.» не несет ответственности в случае внесения изменений в рекомендации по эксплуатации продукции или их устранения, произошедших, в частности, по инициативе производителей автомобилей.

Технические характеристики нашей продукции могут претерпевать изменения в любой момент, с учетом усовершенствования технических и технологических процессов.

Некоторые виды продукции могут не иметься в наличии в отдельных странах.

Заказы осуществляются согласно общим правилам торговли, применяемым в компании «Valeo Service Eastern Europe Sp.zo.o.».

Фотографии и изображения продукции могут не в полной мере соответствовать оригиналам. Воспроизведение всей или части настоящей публикации запрещено без специального письменного согласия компании «Valeo Service Eastern Europe Sp.zo.o.».

Η κατανομή και η σύσταση προϊόντων που εμφανίζονται στους καταλόγους γίνεται λαμβάνοντας υπ όψη την κατάσταση του στόλου αυτοκινήτων στην ημέρα της δημοσίευσής τους.

Η ευθύνη της Valeo Service δεν μπορεί να εμπλακεί σε περίπτωση τροποποίησης, αντικατάστασης ή κατάρτησης των προτάσεων ή των συστάσεων που θα μπορούσαν να προκύψουν κατόπιν πρωτοβουλίας των κατασκευαστών των οχημάτων.

Τα τεχνικά χαρακτηριστικά των προϊόντων μας ενδέχεται να εξελιχθούν ανά πάσα στιγμή λόγω τεχνικών και τεχνολογικών βελτιώσεων.

Μερικοί οδηγοί μπορούν να μην είναι διαθέσιμοι σε όλες τις χώρες.

Οι παραγγελίες διευθετούνται από τους γενικούς όρους πωλήσεων της Valeo Service.

Οι φωτογραφίες και τα σχέδια δεν είναι δεσμευτικά. Η αναπαραγωγή ολόκληρου ή τμήματος αυτού του καταλόγου απαγορεύεται να γίνει χωρίς τη ρητή και γραπτή άδεια της Valeo Service.

EUROPE

FRANCE

VALEO SERVICE FRANCE
70, RUE PLEYEL
93285 SAINT-DENIS CEDEX - FRANCE
Tel.: (+33) 1 49 45 32 32
Fax: (+33) 1 49 45 37 36
S.A.S. au capital de 12 900 000 €
RCS Bobigny B 306 486 408

SPAIN, PORTUGAL

VALEO SERVICE ESPAÑA, S.A.
CALLE RIO ALMANZORA, N°5
AREA EMPRESARIAL ANDALUCIA C.L.A.
28906 GETAFE (MADRID) - ESPAÑA
Tel.: (+34) 91 495 85 00
Fax: (+34) 91 495 86 99
TEL. ATENCIÓN TÉCNICA: 902 011 799
TEL. ATENCIÓN AL CLIENTE: 900 122 657
Valeo Service España Sociedad Anónima
inscrita en el Registro Mercantil de Madrid,
Tomo 972 - Libro 941 de la sección 8a,
Folio 25 - Hoja 65435 - Inscripción 1a NIF. A28772978

ITALY

VALEO SERVICE ITALIA SPA (V.S. ADRIATIC)
VIA ASTI 89
10026 SANTENA (TO) - ITALIA
Tel.: (+39) 011 94 95 1
Fax: (+39) 011 94 95 280
TEL. LINEA TECNICA : 800 805 046
N. Iscrizione al Tribunale di Torino 2009/88 reg. soc.
C.C.I.A.A. 715107 - Capitale sociale € 2.600.000

LIAISON OFFICE IN GREECE
KALAMAKOU AVENUE, 18
ALIMOS - ATHENS - GREECE - PC 17455
TEL.: +302104527447
FAX: +302104527449

LIAISON OFFICE IN SERBIA
BUL. ARSENJIJA CARNOJEVICA 99
LOKAL 4
11070 NOVI BEOGRAD - SERBIA
TEL.: +381 (0)11 260 7754

LIAISON OFFICE IN CROATIA
PODRUZNICA ZAGREB HEKTOROVICEVA 2
tel.: +385 1 644 8288

UNITED KINGDOM

VALEO SERVICE UK LTD
HEMING ROAD - WASHFORD
REDDITCH - WORCS B98 0DZ - ENGLAND
Tel.: (+44) 1527 838 300
Fax: (+44) 1527 523 732
Registration Number: 956685

GERMANY

VALEO SERVICE DEUTSCHLAND GMBH
BRANDENBURGER STRASSE 46
40880 RATINGEN - DEUTSCHLAND
Tel.: (+49) 21 02 865 0
Fax: (+49) 21 02 865 142
Handelsregister Ratingen - HRB 3340

BENELUX

VALEO SERVICE BENELUX B.V.
HEIBLOEMWEG 1
5704 BS HELMOND - THE NETHERLANDS
Tel. BELGIUM (NL): (+32) 2 366 99 17
Tel. BELGIUM (FR): (+32) 2 355 14 46
Tel. NETHERLANDS: (+31) 492 580 894
Fax BELGIUM: (+32) 2 366 04 47
FAX NETHERLANDS: (+31) 492 580 828
K.v.K. Eindhoven 33113859

POLAND, LITHUANIA, LATVIA, ESTONIA, MOLDAVIA, BELARUS, UKRAINE

VALEO SERVICE EASTERN EUROPE Sp. z o.o.
WOŁOSKA 9A
02-583 WARSZAWA POLSKA
Tel.: (+48) 22 543 43 00
Fax: (+48) 22 543 43 05
Valeo Service Eastern Europe Sp. z o.o.; NIP 521-11-44-
752 VAT UE PL5211144572 - REGON 011909673
Wysokość kapitału zakładowego: 4 637 000 PLN
- KRS 56793 Sód Rejonowy dla m. St. Warszawy w
Warszawie,
XIII Wydział Gospodarczy KRS

LIAISON OFFICE IN CZECH REPUBLIC
DEDINSKA 29
16101 PRAGUE 6
CZECH REPUBLIC
Tel.: (+420) 220 102 277
Fax: (+420) 220 102 278

RUSSIA

VALEO SERVICE CO LTD
3RD FLOOR, OFFICE 6
Tel.: (+7) 495 981-06-96
Fax: (+7) 495 787-59-92

SWITZERLAND, AUSTRIA, SWEDEN, FINLAND, NORWAY, DENMARK, ICELAND

VALEO SERVICE EXPORT
70, RUE PLEYEL
93285 SAINT-DENIS CEDEX - FRANCE
Tel.: (+33) 1 49 45 32 32
Fax: (+33) 1 49 45 36 59
S.A.S. au capital de 12 900 000 €
RCS Bobigny B 306 486 408

LIAISON OFFICE IN AUSTRIA
MÜHLGASSE 7
2380 PERCHTOLDSDORF - AUSTRIA
Tel.: (+43) 1 480 42 46
Fax: (+43) 1 480 42 34

LIAISON OFFICE IN SWEDEN
REGUS / VALEO
MASTER SAMUELSGATAN 60, 8TR
SE - 111 21 STOCKHOLM - SWEDEN
Tel.: (+46) 8 50 51 65 50

USA

VALEO SERVICE USA
150 STEPHENSON HWY. TROY,
MI 48083-1116
48083 TROY MICHIGAN
TEL 1.248.619.8300
(888).71.82356

SOUTH AMERICA

VALEO CIBIÉ SERVICE LTDA
RUA SADAE TAKAGI, 2000
BAIRRO COOPERATIVA
09852-070 - SÃO BERNARDO DO CAMPO
SÃO PAULO - BRASIL
Tel.: (+55) 11 43 93 33 54
Fax: (+55) 11 43 93 33 55
C.N.P.J.: 57.010.662/0008-36
Inscrição Estadual : 635.331.124.114

VALEO SERVICE ARGENTINA
RUA SADAE TAKAGI, 2000
BAIRRO COOPERATIVA
09852-070 - SÃO BERNARDO DO CAMPO
SÃO PAULO - BRASIL+
Tel.: (+55) 11 43 93 33 54
Fax: (+55) 11 43 93 33 55
C.N.P.J.: 57.010.662/0008-36
Inscrição Estadual : 635.331.124.114

MEXICO

LIAISON OFFICE IN MEXICO

MONTECITO 38, PISO 14 OFICINA 38.
TORRE WORLD TRADE CENTER
COLONIA NÁPOLES | 03810 | MÉXICO, D.F.
Tel.: +52 (55) 90001588

ASIA, MIDDLE EAST, AUSTRALIA, NEW-ZEALAND

VALEO SERVICE EXPORT
70, RUE PLEYEL
93285 SAINT-DENIS CEDEX - FRANCE
TEL.: (+33) 01 49 45 32 32
FAX: (+33) 01 49 45 36 59

CHINA

**VALEO AUTO PART TRADING (SHANGHAI)
CO., LTD**
201, BUILDING B, IBC TOWER (NEW
INTERNATIONAL BUSINESS CENTER)
391 GUI PING ROAD, SHANGHAI 200233, CHINA
TEL: (+86) 21 5175 2618
MP: (+86) 21 5175 2628
法雷奥汽车零部件贸易 (上海) 有限公司
地址: 上海市徐汇区桂平路391号新漕河
泾国际商务中心B座201
电话: (+86) 21 5175 2618
传真: (+86) 21 5175 2628

INDIA

**VALEO SERVICE INDIA AUTO PARTS
PVT. LTD.**
(A JOINT VENTURE OF VALEO FRANCE & ANAND
AUTOMOTIVE)
BLOCK-A TECCI PARK
173 RAJIV GANDHI SALAI (OMR)
SHOLINGANALLURCHENNAI - 600 119
Tel: (+91) 44 66235000
Fax: (+91) 44 66235011

THAILAND

VALEO AUTOMOTIVE CO., LTD
54 MOO 4 HIGHWAY NO.331 ROAD
I.PLUAK DAENG A.PLUAK
DAENG RAYONG
21140 THAILAND
TEL: +66 (0) 38 265 600
FAX: +66 (0) 38 265 671
REGISTRATION NUMBER: 0105539010549

TURKEY, IRAN, IRAQ, SYRIA, LEBANON, JORDAN, SAUDI ARABIA, UNITED ARAB EMIRATES, KUWAIT, BAHRAIN, QATAR, OMAN, YEMEN, EGYPT

VALEO OTOMOTIV DADITIM A.D.
AYDINEVLER SANAYI CADDESİ
CENTRUM IS MERKEZİ N°3
KAT: 3, DAİRE N°302-303 KÜÇÜKYALI - MALTEPE
34854 İSTANBUL - TURKEY
TEL: (+90) 216 518 75 75
FAX: (+90) 216 519 93 14

AFRICA, DOM-TOM

VALEO SERVICE EXPORT
70, RUE PLEYEL
93285 SAINT-DENIS CEDEX - FRANCE
TEL.: (+33) 01 49 45 32 32
FAX: (+33) 01 49 45 36 59
S.A.S. au capital de 12 900 000 €
RCS Bobigny B 306 486 408

LIAISON OFFICE IN TUNISIA
CENTRE D'AFFAIRES REGUS
IMMEUBLE CARTHAGE
RUE DU LAC DE CONSTANCE
1053 TUNIS - TUNISIA
TEL.: (216) 71 965 002
FAX: (216) 71 965 137
MOB: (216) 98 34 91 38



Air Quality Concept



Clim Filter™
Filter the air in the cabin
+
Clim Pur™
Clean the air conditioning system
+
Clim Spray™
Purify and perfume the cabin

www.valeoservice.com



valeo added ■■■■■■



Automotive technology, naturally

Valeo Service - Société par Actions Simplifiée - Capital 10 900 000 euros - 306 486 408 R.C.S. Bobigny - 70, rue Pleyel 93200 Saint-Denis France - Picturas / Over / © Christian Schiyye - Compagnie - Packaging Agence POP - Design - pensons-complet.com - Advance - bjpy - Acam - Price - 3 euros - Ref. 95558