



# Lighting Systems

From light to advanced  
vision technologies





## Valeo, your Lighting partner

As one of the world's leaders & multi-specialist in Visibility and Lighting systems, Valeo offers you:

- Full information about lighting technology, from replacement parts to diagnosis and maintenance.
- A complete aftermarket product offer with more than 2500 part numbers.
- 100% Valeo O.E. on headlamps, rearlamps, foglamps and DRL.
- A full range of Halogen and LED auxiliary lamps for passenger cars, trucks and agricultural vehicles.
- A complete range of bulbs specifically developed by Valeo for the aftermarket.
- A full range of services available: training, technical support, point of sales material, logistics "speed, service and quality".

**Valeo**

# Table of Contents

1. Disclaimer	3
2. valeo-techassist.com	4
3. valeoscope library	5
4. Valeo, the lighting systems multi-specialist	6
5. The lighting system: what is light?	7
5.1. The human eye	8
5.1.1. The eye sensitivity	8
5.1.2. Day and night-time visions	8
5.2. Light sources basics	9
5.2.1. The luminous spectrum	10
5.2.2. Light colour	11
5.3. Photometric basics	12
5.3.1. Light Intensity	12
5.3.2. The luminous flux	13
5.3.3. The illuminance	14
5.3.4. The luminance	15
5.3.5. The luminous efficacy	17
6. Lighting system: to see and to be seen	18
6.1. ECE regulations for lighting	19
7. Headlamps beams	20
7.1. Low beam	21
7.2. High beam	21
7.3. Fog light beam	21
7.4. The cut-off	22
7.5. Beam's downward inclination	23
7.5.1. Low beam inclination ranges	24
7.5.2. High beam inclination ranges	24
7.5.3. Fog light inclination ranges	24
7.6. Aiming setup and correction	25
7.6.1. Initial aiming	25
7.6.2. Aiming correction (levelling)	25
7.6.3. Manual levelling	26
7.6.4. Automatic levelling	27
7.7. Headlamp fixation-points	27
8. Beams photometric characteristics	28
8.1. What must be illuminated on the road?	28
8.2. Introduction to photometric specifications	29
8.3. Photometric charts	30
8.3.1. Photometric charts depend on light sources	31
8.3.2. Photometric charts by country	31
9. From Halogen to Xenon front lighting	33
10. Halogen lamps	34
10.1. Halogen regenerative cycle	34
11. Gas-discharge lamps	36
11.1. Xenon lamps structure	38
11.1.1. Xenon, a discharge lamp tuned to automotive applications	39
11.2. Xenon system operation	41
11.3. Xenon lamp types and numbering	44
11.3.1. D6S/D8S to democratise Xenon lamp	45
11.3.2. D5S a fully integrated Xenon lamp	45
12. Light source positioning	46
13. High and low beams optical systems	47
13.1. Parabolic type	48
13.2. Complex-surface type	49
13.3. Complex-surface and Xenon lamps	49
13.4. Glare management in reflector-type optics	50
13.5. Elliptical-type optics	51
13.5.1. The reflector: a key component to elliptic headlamps!	52
13.5.2. The cut-off in elliptical-type optics	53
13.5.3. A vast product diversity	53
13.6. Xenon Bi-function technology	54
13.6.1. Xenon Bi-function with elliptic projector	54
13.6.2. Xenon Bi-function with complex-surface reflectors	55
14. From Xenon to LED	56
14.1. What is LED technology about?	56
14.2. A bright future for LED technology in car applications	58
14.3. Application for Ford Mondeo	58
14.4. Application for Seat Leon	59
14.5. What are the benefits of LED technology?	60
15. AFS - Adaptive Front Lighting Systems (AFS)	61
15.1. Bending lights	61
15.1.1. Fixed Bending Light	61
15.1.2. Cornering	62
15.1.3. Dynamic Bending Light	62
15.2. Full Adaptive Front Lighting "Full AFS"	64
15.2.1. Full AFS for the Audi Q7	65
15.2.2. Automatic operation of the AFS	66
15.2.3. AFS - Classes and Modes	67
15.2.4. Additional provision to the AFS systems	72
16. Glare-Free High Beam (GFHB)	73
16.1. Why the Glare-Free High Beam?	73
16.2. Valeo BeamAtic® Premium System	74
16.2.1. BeamAtic® Premium applications	77
16.3. What makes a good Glare-Free High Beam system?	78
16.4. LED-Based Glare-Free system designs	79
17. What about lasers in automotive lighting?	82
17.1. Laser white source benefit from LED experience	82
18. Signalling	84
18.1. The trend for a massive use of LEDs is engaged	85
18.2. MICROOPTICS styling breakthrough for front & rear night-time signature	85
18.3. Photometry in signalling functions	86
18.4. Signalling gets smarter!	88
19. Lighting systems servicing	89
19.1. Light source selection	89
19.2. Light source installation	90
19.3. Fitting Xenon lamps	90
19.3.1. Ballast and Ignitor installation	91
19.4. Aiming correction in workshops	92
19.4.1. Measurement conditions	93
19.4.2. Vehicle preparation	93
19.4.3. Measuring AFS aiming	93
20. Regulations and marking	95
21. How to use Valeo lighting systems catalogue?	96
Tech'Care - Valeo Service technical solutions	97



# Foreword

## Our multi-specialist expertise is rooted in our genes.

As one of the leading automotive system designers and manufacturers for OE, Valeo offers 14 product lines for passenger cars and 8 product lines for heavy duty applications. Valeo supplies parts to every distribution channel, including car manufacturers, factories and dealerships, independent aftermarket and modern distribution, in more than 150 countries all over the world.

## The lighting market

Lighting systems on vehicles play a critical part in the safety of both the driver and other road users to see and to be seen. The risk of having a car accident at night is three times higher than during the day, more than 40% of fatal accidents occur when it is dark although only 20% of all journeys are driven at night\*. Car makers and component manufacturers are constantly developing new technologies to offer a wider and longer field of vision to improve anticipation under all driving conditions. As an expert in lighting systems, Valeo has always been at the forefront developing and providing innovative

solutions, in terms of efficiency, design and energy consumption. Valeo Service offer a wide range of original equipment systems produced according to the highest quality standards.

Valeo Service is proud to present to you its 2015 Lighting Systems Technical handbook as part of its technical collection.

From human visual perception, to light sources evolutions, regulations, photometric knowledge and Valeo latest technologies, this book will allow you to better understand lighting systems and their importance for road user safety.

Last but not least, the most frequently asked questions will be addressed.

**Valeo: From original equipment leadership to aftermarket excellence**



\*BAST report "Das Unfallgeschehen bei Nacht", 1988



# Disclaimer

Whilst we endeavor to ensure that the information included in this training documentation is correct, we do not warrant its completeness or accuracy; nor do we commit to ensuring that the material on the documentation is kept up to date.

To the maximum extent permitted by applicable law, we exclude all representations, warranties and conditions relating to this documentation and the use of this documentation (including, without limitation, any warranties implied by law in respect of satisfactory quality, fitness for purpose and/or the use of reasonable care and skill).

Nothing in this disclaimer will: (a) limit or exclude our or your liability for death or personal injury resulting from negligence; (b) limit or exclude our or your liability for fraud or fraudulent misrepresentation; (c) limit any of our or your liabilities in any way that is not permitted under applicable law; or (d) exclude any of our or your liabilities that may not be excluded under applicable law.

The limitations and exclusions of liability set out in this section and elsewhere in this disclaimer: (a) are subject to the preceding paragraph; and (b) govern all liabilities arising under the disclaimer or in relation to the subject matter of this disclaimer, including liabilities arising in contract, in tort (including negligence) and for breach of statutory duty.

To the extent that this documentation and this training documentation are provided free of charge, we will not be liable for any loss or damage of whatsoever nature.

The content of this Document is protected by intellectual property laws including copyright and trademark law. Its content, including texts, pictures, drawings, logos, trademarks is part of Valeo know how and is Valeo's sole property. This Document and its content could not be used without Valeo's written prior consent.

Any non authorized copy, duplication, distribution or reproduction is strictly prohibited and any infringer could be prosecuted.





## valeo-techassist.com

Valeo Techassist can assist you all the way through the following service processes:

- Product information: product data sheets with details not included in the catalogue.
- Common failures: step-by-step failure diagnosis guides.
- Updates about Valeo Service products: access to all Technical Service Bulletins.
- Help through FAQs and the Valeo Service technical hotline.
- Valeo workshop tools: user manuals, service manuals and software updates on Valeo Service tools.
- Online training modules (e-learning) about most modern product technologies.
- Interactive feedback:
  - add your personal feedback to Valeo Service and contribute to future documents.
  - provide satisfaction feedback.



Valeo TechAssist is a web based application, specifically developed for repair workshops, automotive spare parts distributors and technical trainers.

Valeo TechAssist is available online in 10 languages. Logon to the website at [www.valeo-techassist.com](http://www.valeo-techassist.com).

Valeo TechAssist is not only a technical database, but also a learning platform and a forum of information. It covers passenger cars and all Valeo product lines.

The information in Valeo TechAssist is structured in four comprehensive domains:



### 1. Product documentation



### 2. Technical assistance



### 3. Workshop tools



### 4. Technical training



# valeoscope library

Take benefit from Valeoscope Technical hand books to rediscover Valeo technologies.

- Systems environment and constrains.
- Systems working principles.
- Systems evolutions.
- Servicing and fitting advices.

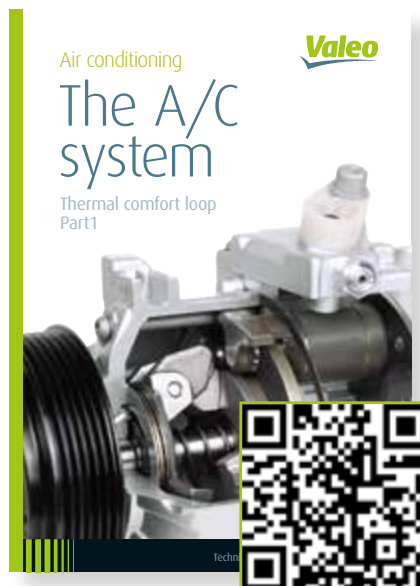



# 4

## Valeo, the lighting systems multi-specialist

Valeo is an independent industrial group fully focused on the design, production and sale of components, integrated systems and modules for the automotive industry, mainly for CO<sub>2</sub> emissions reduction. Valeo is ranked among the world's top automotive suppliers.



Valeo has 4 Business Groups, comprising 16 Product Groups, supplying the Original Equipment Market (O.E.M.) and the Aftermarket. The 4 Business Groups are: Powertrain Systems, Thermal Systems, Comfort and Driving Assistance Systems, and Visibility Systems.

Lighting products portfolio is part of Valeo's Visibility Business Group.



# The lighting system: what is light?

Light is one of the many electromagnetic radiations that are surrounding us.

From X-rays to submarine communication systems all radiation sources are defined by their wavelength in meters.

As the wavelength field is very large, several subunits are used depending on the emission type.

Visible light is composed of a range of wavelengths from 380 nm "blue light" to 750 nm "red light" (nm for Nano Meter).

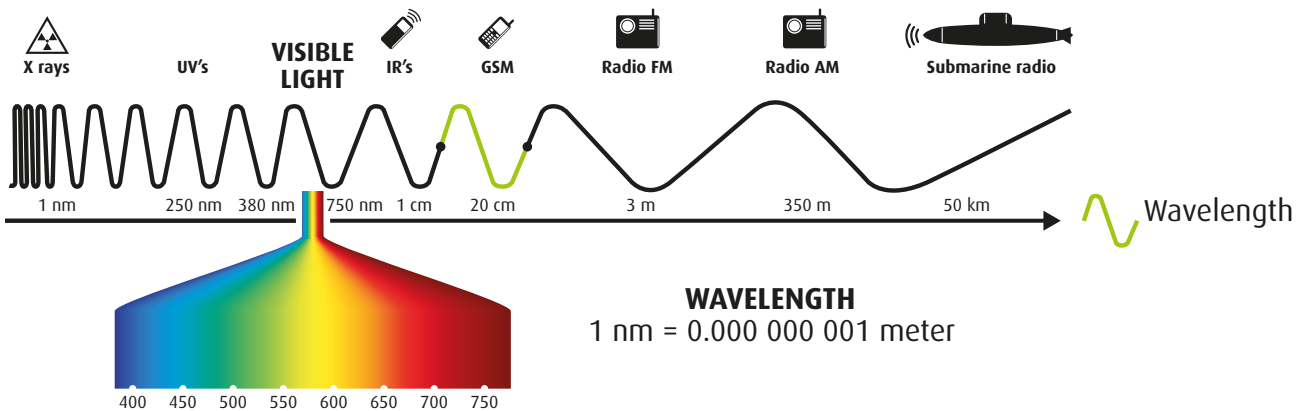

## 5. The lighting system: what is light?

### 5.1. The human eye

#### 5.1.1. The eye sensitivity

The eye is a sensor, it is able to sense a small portion of all electromagnetic radiations. Colours are the way human eyes and brains can distinguish different wavelengths of light.

Some colours are better perceived than others, this is due to the structure of the human eye.

The visible wavelengths are usually between 400 nm and 700 nm, and the sensitivity of the human eye to wavelengths outside this range drops dramatically.

#### 5.1.2. Day and night-time visions

Human eyes behave differently at night compared to daylight. The sensitivity of the human eye to colours strongly depends on whether it is light or dark.

In dark conditions, a whiter light (bluer in the spectrum) improves visibility.

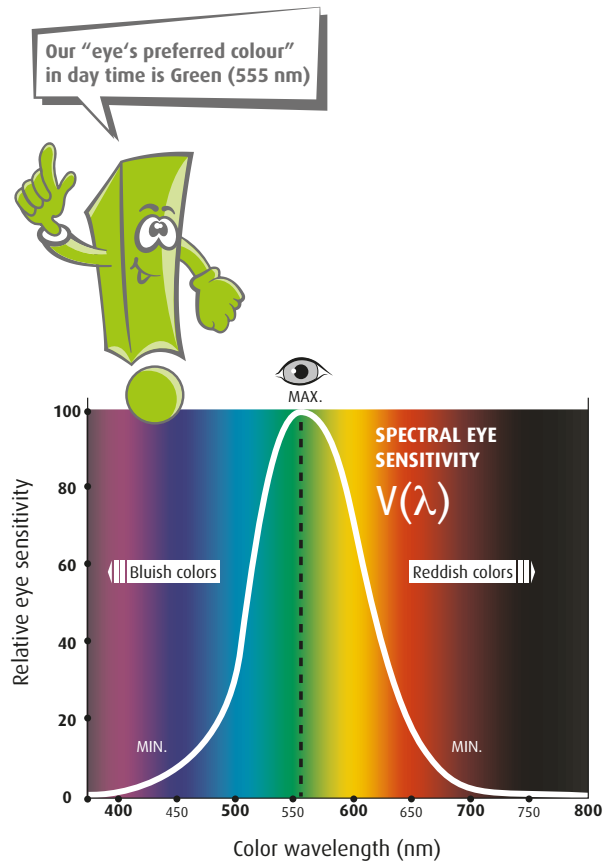

#### Night-time



- Peripheral field of view.
- Detection of movements and changes.
- Not colour sensitive.





## 5.2. Light sources basics

The most natural light for human eyes is daylight.

The daylight is composed of a range of different colours; called a "polychromatic colour".

This is demonstrated when light passes through a prism, it is fractured into different colours to form a spectrum.

Each light source is characterized by a light spectrum showing wavelength against power for each colour.

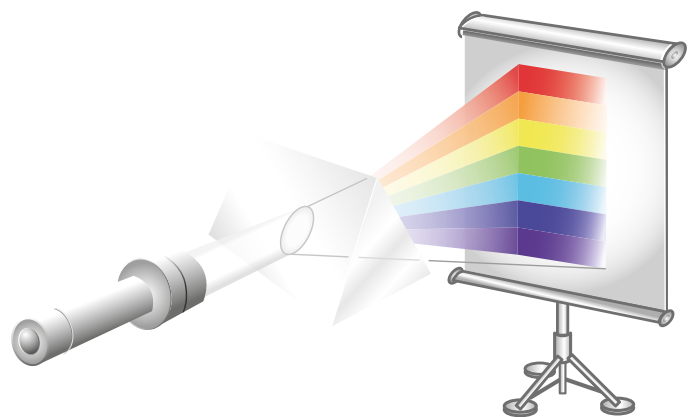

Each light source is characterized by a light spectrum showing wavelength against power for each colour.

### Daylight

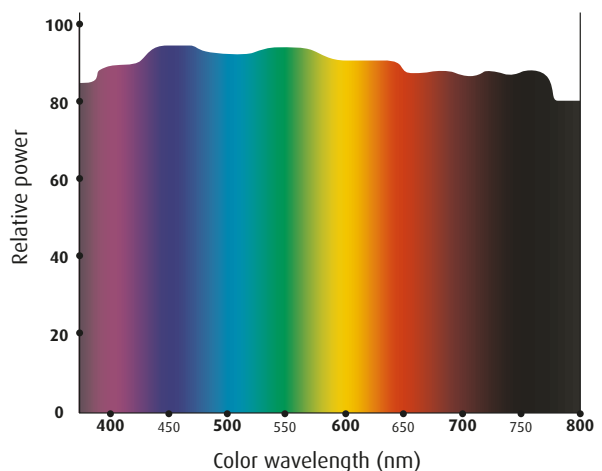

### Day and night-time eye sensitivity

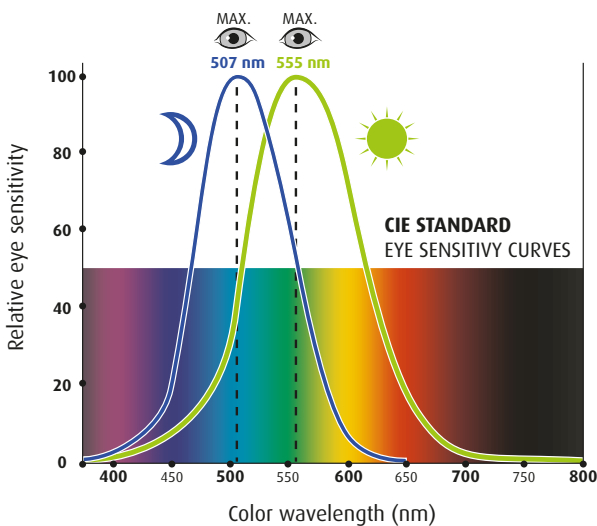

#### Day-time



- Central field of view.
- Perception of details.
- Colour sensitive.

Automotive lighting systems are designed according to the visual perception of the human eye and are developed to compensate our visual weaknesses in some driving situations.

The lighting systems on vehicles have evolved enormously in the last few generations to ensure road users comfort, safety and security.

# 5. The lighting system: what is light?

## 5.2.1. The luminous spectrum

The visible spectrum depends on the type of light source. The following figures illustrate main light source spectrums.

- Daylight is the most homogeneous light.
- Light from Tungsten lamps is more into the red light spectrum (so called a hot colour).
- Low pressure Sodium lamps are almost monochromatic light sources (a small wavelength range is emitted).

The diversity of light sources is linked to the variety of illumination needs as well as technologies constant evolution, some are better known than others to the public.

The domestic market and regulations are pushing for low consumption and CO<sub>2</sub> friendly lighting technologies, compact fluorescent lamps and Halogen lamps are very common today.

This trend to decrease power consumption is also true for automotive light sources but it is a partial reason for this change. Security features like night vision quality and day time visibility are major vectors too.

Tungsten

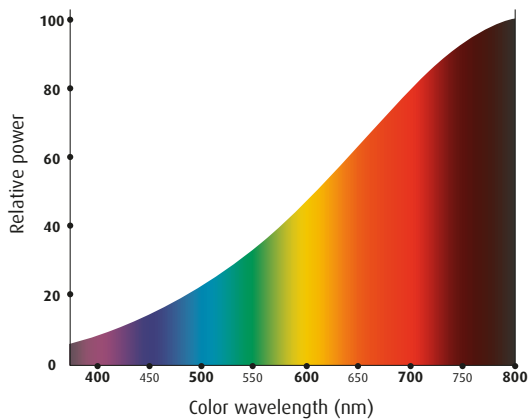

Low pressure Sodium (SOX)

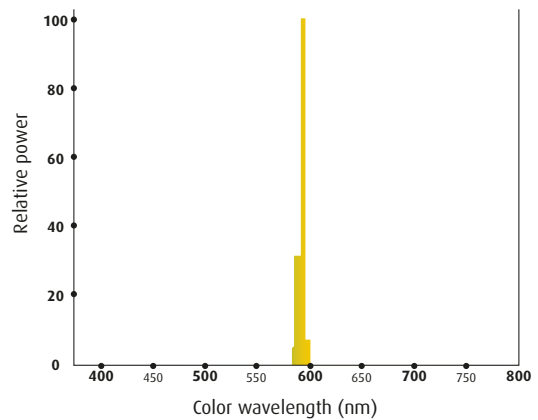

Metal halide 3000 K (MBI)

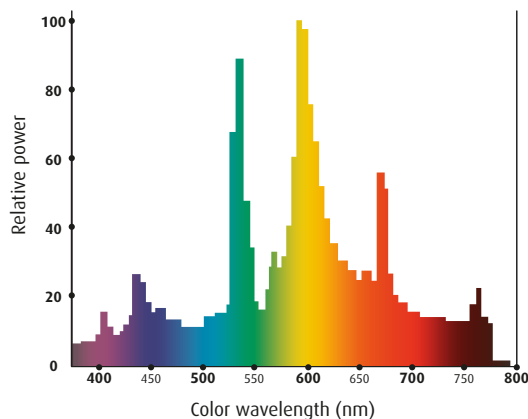

High pressure Sodium (SON)

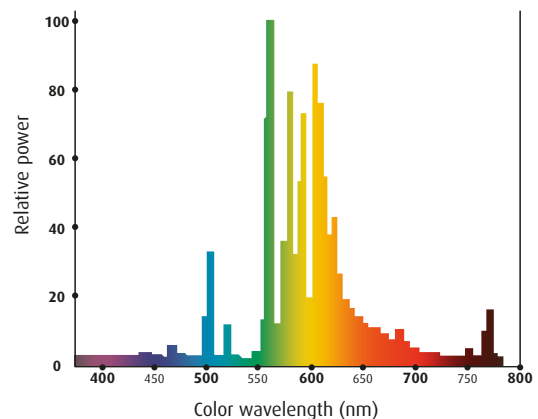

## 5.2.2. Light colour

### 5.2.2.1. The colourimetric graph: CIE grid

The International Commission on Illumination also known as the CIE from its French title is an international standardization body, it is devoted to worldwide cooperation for lighting, colour and vision purposes.

#### The CIE has defined a standard grid that permits to specify light sources colours: the CIE grid

The CIE grid represents all of the colours that are visible to the average person.

- The edges of this diagram corresponds to the so-called monochromatic lights. Monochromatic colours are specified by their unique or preponderant colours and wavelengths in nanometres (nm).
- Chromatic lights are located in the interior of this diagram. Chromatic colours are specified with the so-called X and Y coordinates.
- White colours are located in the centre of this global chromaticity diagram. As "whites" are at the border of several chromatic colours, there is a large pallet of white colours.

### 5.2.2.2. White colours

White colours are defined in the CIE grid, either by their "colour coordinates" or their so called "colour temperatures".

- Colour coordinates x,y are defined on the CIE chromaticity diagram
- Colour temperature (in Kelvin: K) is another way to characterize white illuminants.

Colour temperatures over 5000 K are called cold colours (bluish white), lower colour temperatures (2700–3000 K) are called warm colours (yellowish white through red).

## CIE chromatic diagram

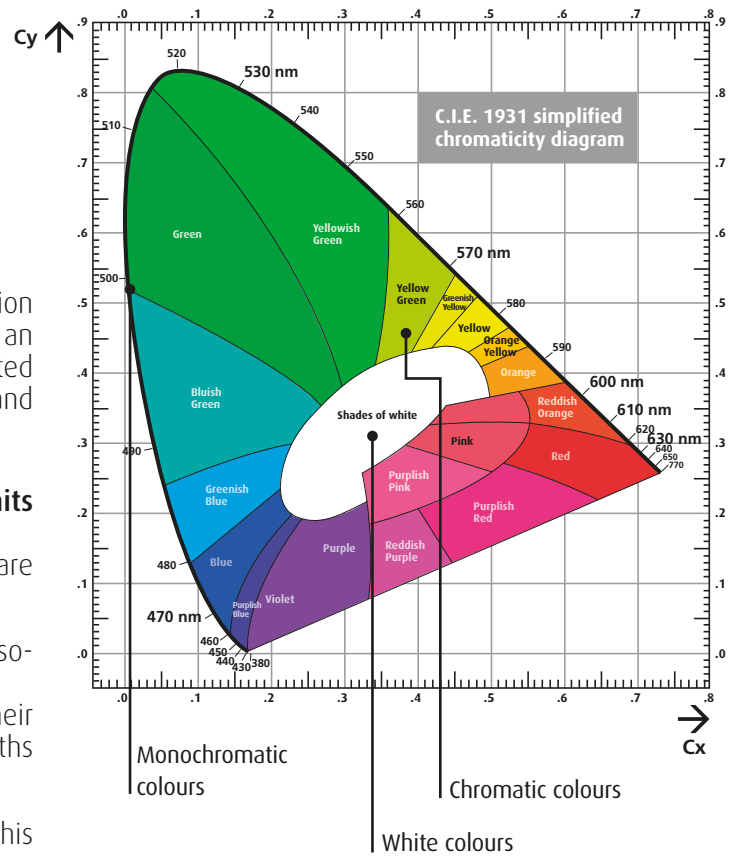

## Focus on white colours

CIE 1931 x,y chromaticity diagram

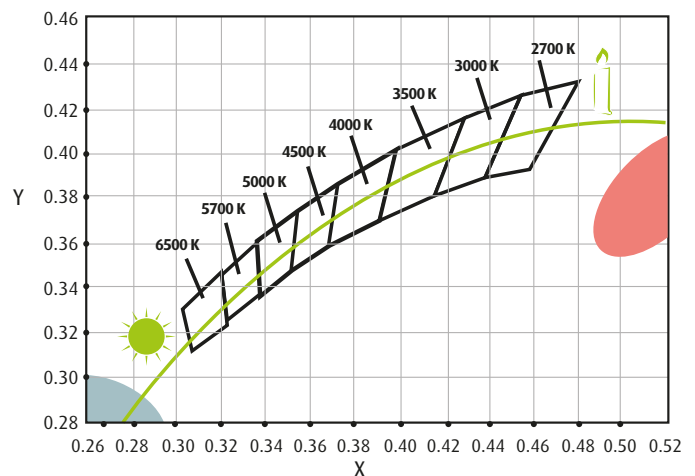

- Day light temperature  $\approx$  6500 K
- LEDs  $>$  4500 K
- Xenon lamps  $\approx$  4300 K
- Halogen lamp  $\approx$  2800 K
- Candle flame  $\approx$  1850 K



# 5. The lighting system: what is light?

## 5.3. Photometric basics

Photometry is the science concerned with measuring human visual response to light, here are a few basics that are good to know prior to jumping into the lighting systems.

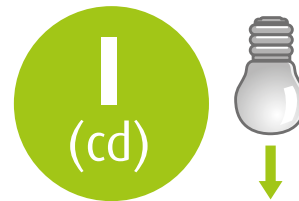

### 5.3.1. Light intensity

The intensity is the luminous energy from a lighting source in a specific direction:

- **Symbol:** I
- **Unit:** Candela (cd)

Light intensity varies depending on which direction the light source is being viewed from. This figure below illustrates a light source emission profile; it can be seen how intensity drops from 140 cd@20° (front viewing) to 70 cd@90° (side viewing).

Some examples of Candela intensity on automotive lighting systems:

- **A candle: 1 cd (reference)**
- Parking lights: 2cd
- Position lights: 4 cd
- Direction lights: 50 cd
- **Stop lights: 60 cd**
- Reversing lights: 80 cd
- Fog lights: 150 cd
- Daytime Running Lights: 500 cd
- Low/High beams >1000 cd



Intensity versus angular viewing

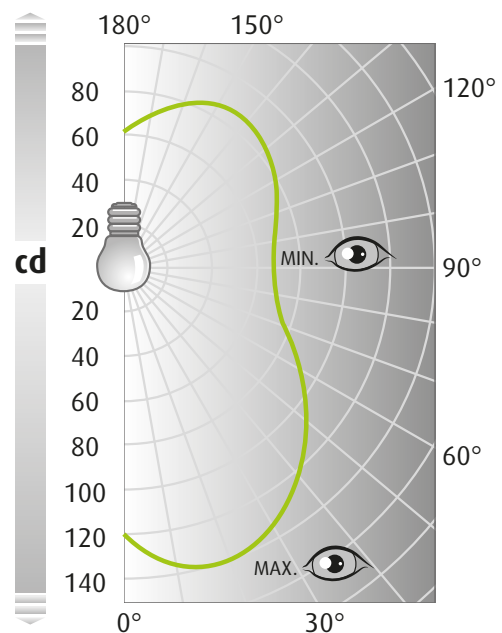

### 5.3.2. The luminous flux

The luminous flux is the complete light output radiated from a light source.

- **Symbol:**  $\Phi$
- **Unit:** Lumen (lm)

**The Lumen unit is defined based on the human eye sensitivity curve**

The following illustrations show how a human eye perceives a light source depending on its colour composition.

The red curve illustrates the sensitivity of the human eye to colours stimulus.

It can be seen that a lot of colour peaks on source N°2 are close to the red line; This means that the peaks in source N°2 will be perceived by the human

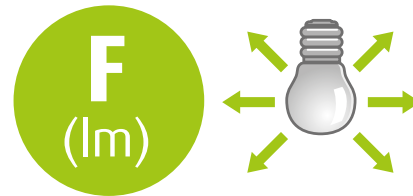
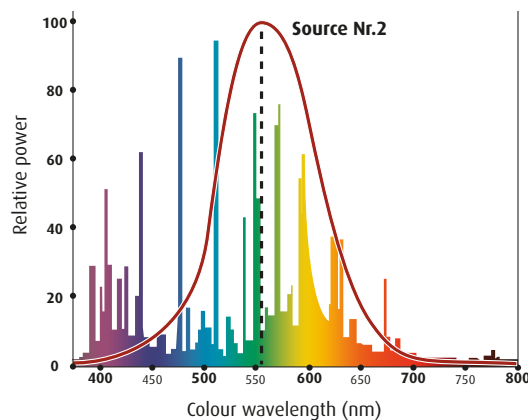
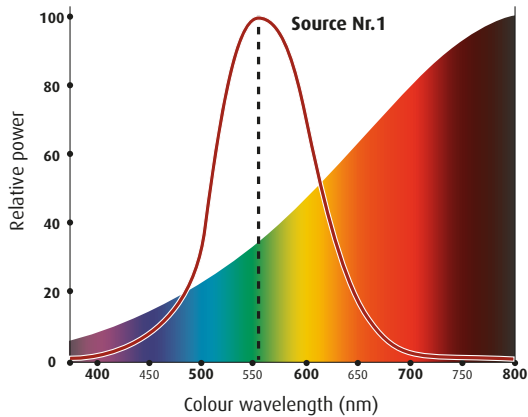

eye as a higher luminance source than in source N°1.

**The theoretical and ideal light source for a human eye would have a spectral decomposition fitting perfectly to the red line.**

Below shows types of automotive bulbs and their light output in Lumen.

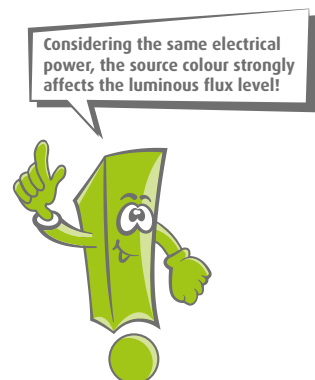
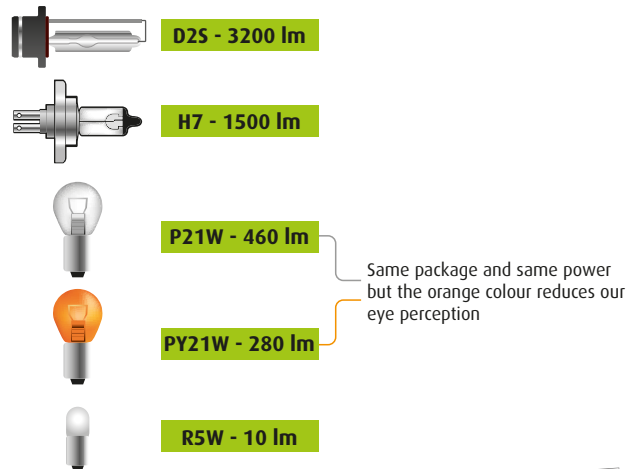

# 5. The lighting system: what is light?

## 5.3.3. The illuminance

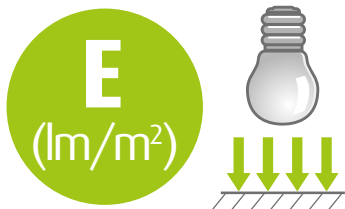

The luminous flux from a light source (lumens) falling on a unit of surface ( $m^2$ ) is called illuminance.

- **Symbol:** E
- **Unit:** Lumen/ $m^2$  also called Lux

**Illuminance levels on the road are specified according to automotive standards, they depend on the type of light source, such as incandescent (Halogen), gas discharge (Xenon) or LED (Light Emitting Diode) lamps.**

The diagram below is the illuminance projection of a headlamp equipped with a Xenon lamp. This curve is called an Isolux curve where lines indicate illuminance levels in steps.

On this example, the illuminance reaches a maximum at 100 lux in the front of the car and minimum of 1 Lux on the outer line (1.0).

**The illumination level does not make allowance for the amount of light reflected off the surface.** The reflected light is called the luminance; this depends on the nature of the surface, including its colour.

Roads and road markings are specified in standards that set minimum reflection levels.

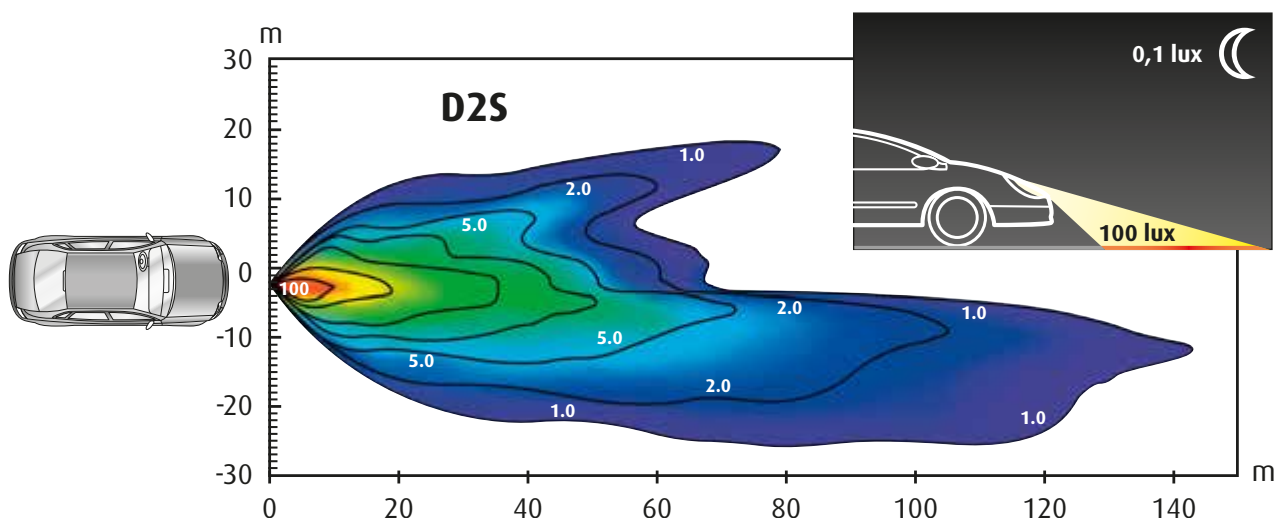

### 5.3.4. The luminance

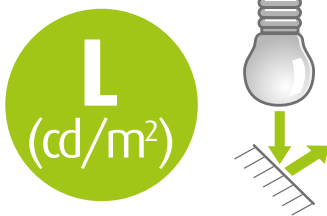

The luminance measures the reflected light from a surface to a given direction; the surface can itself be light-emitting, transmitting or reflecting light from another source.

The luminance is the perceived brightness, it is used to categorise:

- Light sources (eg. lamps).
- Lighting systems (eg. headlights).
- Any surface that is bright (eg. road signs).

The luminance is related to a luminous intensity emitted per unit of area from a surface in a specific direction.

- **Symbol:** L
- **Unit:** Candela per m<sup>2</sup>

To summarise:  
 - Illuminance (Lumen/m<sup>2</sup>) is all the light that shines on a surface  
 - Luminance (Candela/m<sup>2</sup>) is the reflected light from a surface to one direction

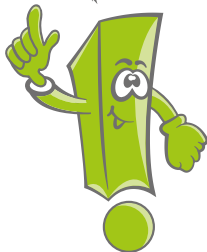

#### 5.3.4.1. Daytime Running Light (DRL) luminance

Daytime Running Lights belong to the signalling product family. DRLs are a perfect example of a high luminance application, they produce a huge intensity of light in a compact reflector.

The ECE R87 regulation specifies an apparent surface between 25 cm<sup>2</sup> and 200 cm<sup>2</sup>, and an intensity level between 400 and 1200 cd.

The apparent surface and the intensity permit to calculate and see how huge can be the maximum luminance level on Daytime Running Lamps (480000 cd/m<sup>2</sup>).

#### ECE R87 Daytime Running Light luminance boundaries

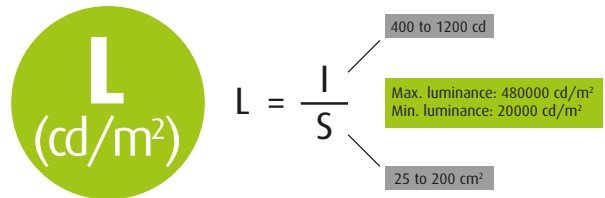

Where L is luminance, I is intensity of light and S is surface area of emitted light.

## 5. The Lighting System: what is Light?

### 5.3.4.2. Reflectors luminance

Reflectors luminance occurs by reflecting light from another source.

#### Illuminance application in reflectors



### 5.3.4.3. Road luminance

The European standard, EN 13201, provides values for average road surface luminance. The luminance is a value of the luminous flux falling onto a road and the reflection characteristics of that surface.

Road surface reflection characteristics depend on the nature of the surface (colour, aggregate type, binding agent and manufacturing method, texture, etc.) and physical state (wear, cleanliness and moisture of the surface). Luminance at any point depends on the emitted light angle and the observation angle.

Asphalt tends to get lighter as it ages, due to oxidation and degradation of the binder, revealing the lighter-coloured aggregate.



The standard is to be able to see reflections between 60-160 m ahead at a height of 1.5 m. Asphalt reflectivity depends on surface conditions, dry, wet, icy, snowy, leaves, mud, etc. Due to asphalt's relatively low reflectivity, markings are mandatory to highlight junctions, central reservation, road borders, etc.

### 4.3.4.4. Road marking luminance

The European standard, EN 1436, gives values for marking surface luminance.

It refers to:

- Road marking colours (white or yellow).
- Reflection during daylight or when under road lighting.
- Reflection from vehicle headlamp illumination:
  - for dry road markings
  - for road markings in wet conditions, etc.

Similar to the asphalt luminance coefficient, EN 1436 stipulates the visibility of the road markings as seen by a driver at a distance of 30 meters when illuminated by the vehicle's headlamps.

#### Poor luminance with a worn marking



*Barely visible marking.  
Worn road markings lead to a poor luminance level.*



### 5.3.5. The luminous efficacy



Luminous efficacy is a figure of merit for light sources; it is the "proportion" of visible radiations over the entire radiation emitted by this light source.

The luminous efficacy is expressed in lumens per watt, it is the ratio between the total luminous flux emitted (Lumens) by the total amount of electrical power (Watts) it consumes.

Incandescent lamps radiate a lot of heat (infra red) which decreases the proportion of the visible radiation over the entire radiation, their efficacy is quite poor (25 lm/W).

As for all systems fitted in cars, efficiency optimization also applies to light sources. It is an important factor in overall efforts to improve energy consumption and reduce vehicle CO<sub>2</sub> emissions.

LEDs efficacy (>100 lm/W) overpasses today the Xenon technology; it makes LED designs perfect candidates for many new applications.

Higher efficacy → Same luminous flux with lower electrical power consumption.

#### Incandescent lamp

**H7** - 12 V 55 W

1500 lm @ 55 W = 27 lm/W

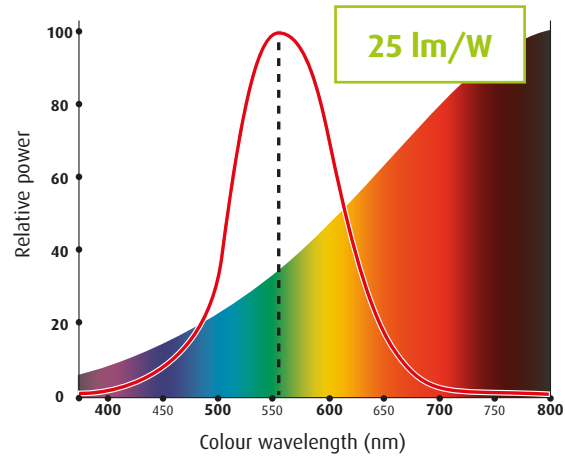
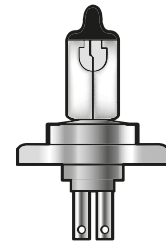

#### Xenon lamp (HID)

**D4S** - 42 V 35 W

3050 lm @ 35 W = 87 lm/W

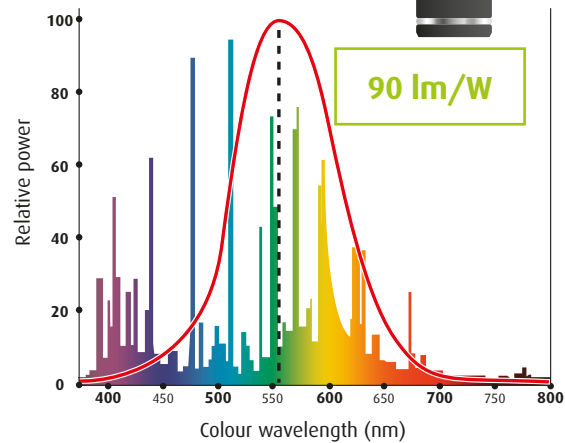
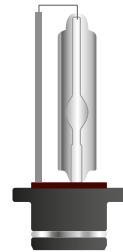

#### LED module

**OSLON Black Flat** - KW H2L531.TE

800 lm @ 6.5 V- 1 A = 123 lm/W

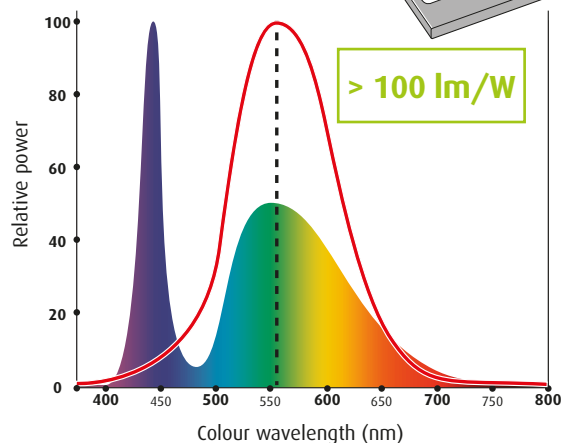
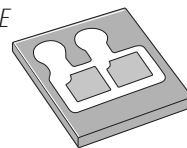

# 6

## Lighting system: to see and to be seen

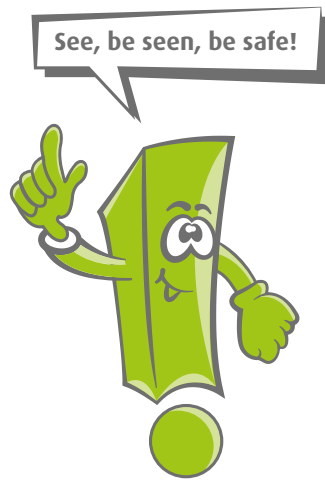

The lighting system can be divided in two subfamilies to see and to be seen.

- **Lighting:** to project light to better anticipate the road ahead (bends, road signs, pedestrians, trees, etc). The better you can see the safer you are.
- **Signalling:** to allow light to be seen by other drivers and pedestrians: being seen allows others to better detect and anticipate your movements.

Both lighting and signalling functions are specified and designed according to stringent regulations.

**From type of light source used to projector design, basic levelling systems to latest Adaptive Front Light Systems (AFS), automotive lighting systems are continuously improving driver comfort and security.**

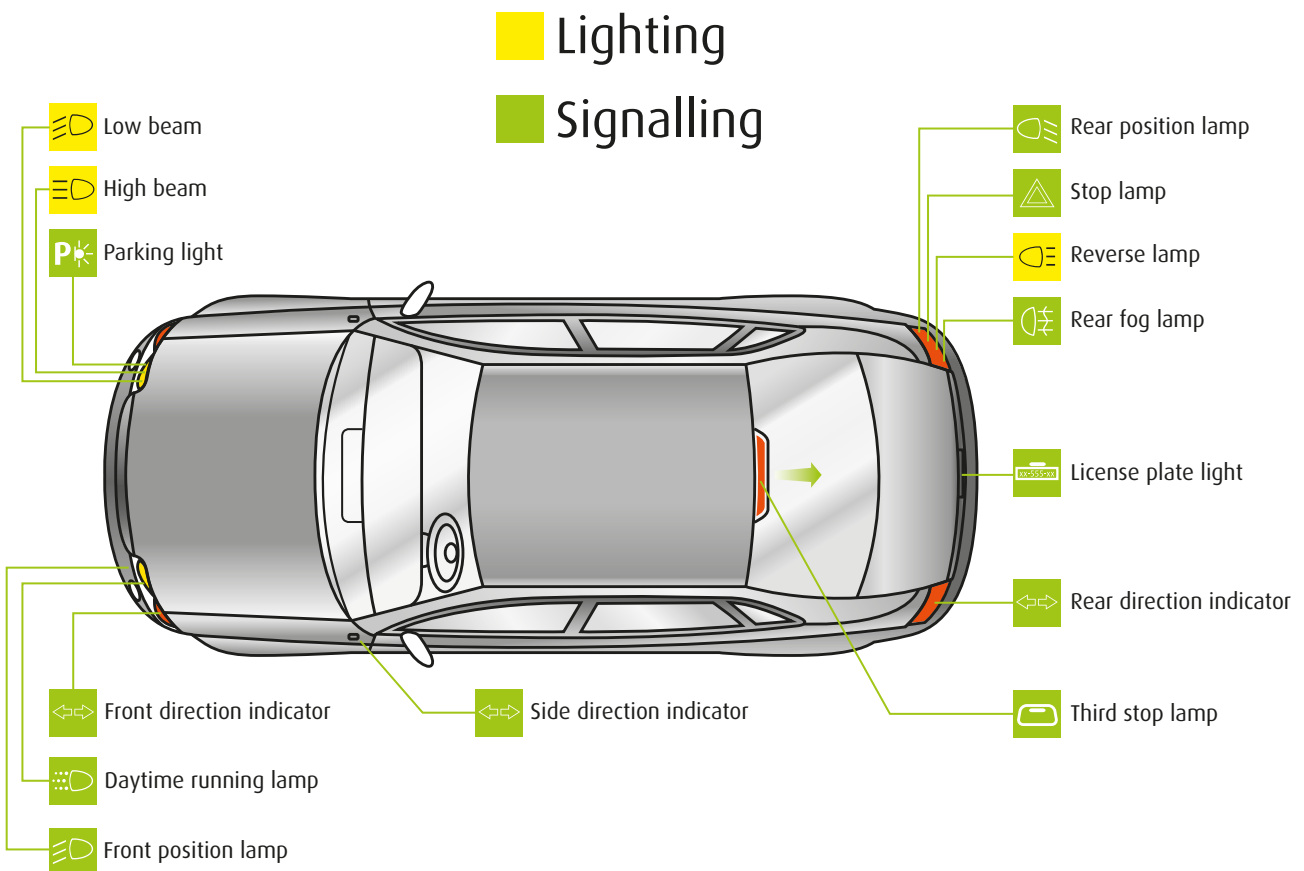

## 6.1. ECE regulations for lighting

European Commission regulations for lighting system are classified as follows:

R37	LIGHT SOURCES - FILAMENT LAMPS
R99	LIGHT SOURCES - HID LAMPS
R112	LOW AND HIGH BEAMS - FOR HALOGEN LAMPS AND LED SOURCES
R98	LOW AND HIGH BEAMS - HID LAMP SOURCES
R19	BEAMS - FRONT FOG LAMPS
R87	DAYTIME RUNNING LAMPS
R48	SETUP ON THE CAR
R123	AFS BEAMS - HALOGEN, XENON AND LED LIGHT SOURCES

# 7 Headlamps beams

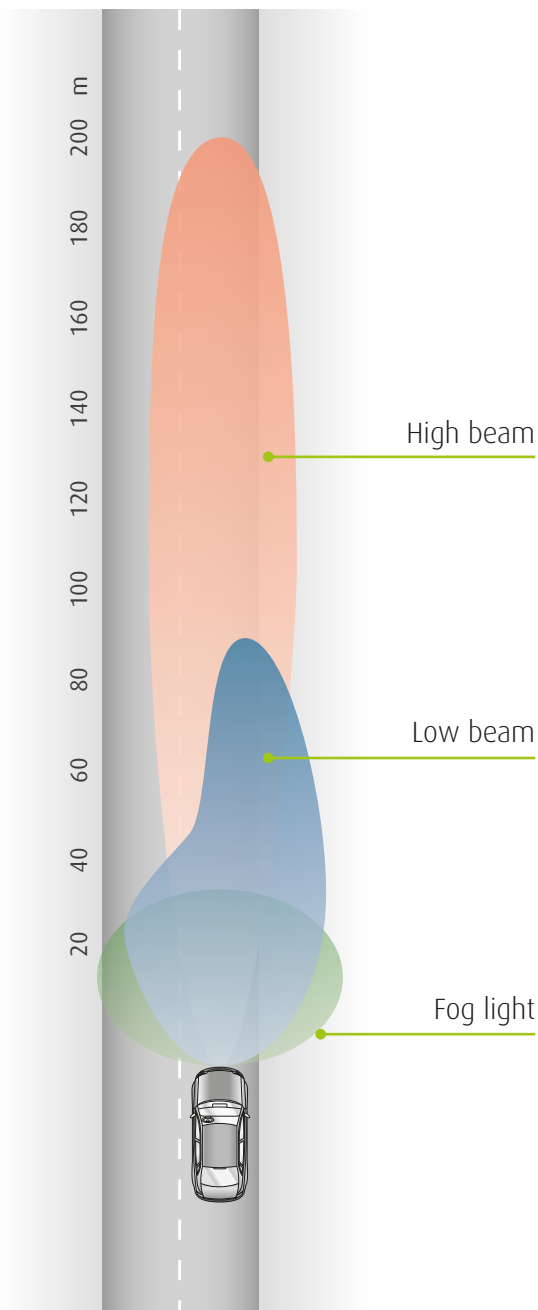

A good front lighting function provides maximum visibility with minimum inconvenience for other road users.

Headlight beams are standard patterns that set the light projection levels and limits on the road.

Several beams are defined:

- Low beam also called passing beam or dipped beam.
- High beam also called main-beam or full-beam.
- Fog beam.

## *Beam types*

Beams can be defined according to their shape and performance:

- The **“Width”** area: where illuminance covers the whole road width in the driver’s near field of view.
- The **“Comfort”** area: which corresponds to the driver main vision zone.
- The **“Range”** area: where the maximum illuminance level occurs far on up to the road.

## 7.1. Low beam

Low beams provide a light distribution to give adequate forward and lateral illumination without dazzling the oncoming vehicles.

- **Width:** Ensures proper positioning of the vehicle in bends or in case of reduced visibility (fog) / between 20 and 30 meters.
- **Comfort:** where you look, between 30 and 60 meters.
- **Range** more than 60 meters.

The low-beams shall remain switched when the main beams are activated.

### Low beam

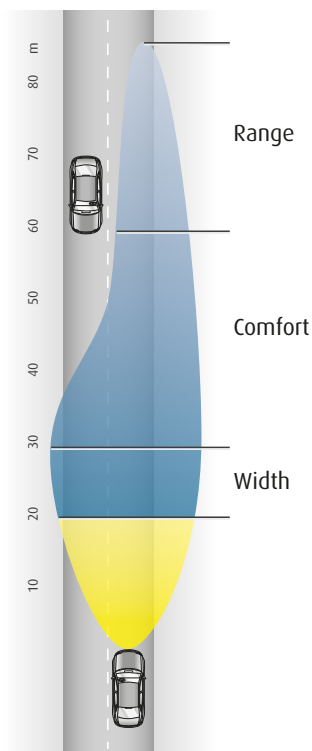

## 7.2. High beam

High beams provide a centre-weighted distribution of light with no control of glare.

- **Comfort:** between 50 and 150 m.
- **Max. range:** more than 150 m.

### High beam

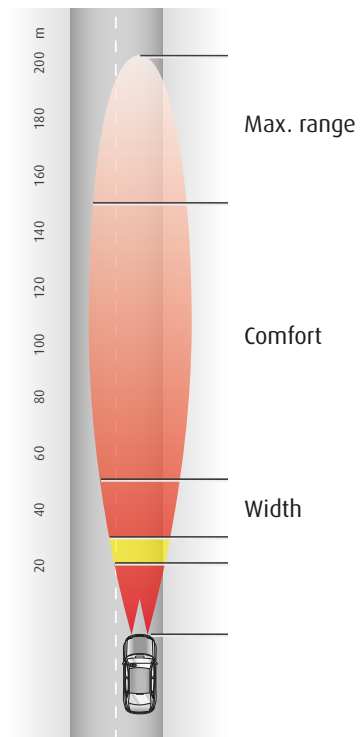

## 7.3. Fog light beam

Front fog beams provide a wide, bar-shaped beam of light with a sharp cut-off.

- **Range:** 25 m.

### Fog beam

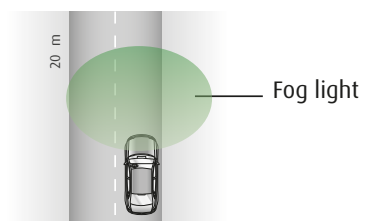



## 7. Headlamps beams

### 7.4. The cut-off

Depending on their type, projectors must include a system to produce a cut-off line. The cut-off line defines a limit where light should not be projected, low beams and fog beams must comply with this but no legislative cut-off point is required for the high beams.

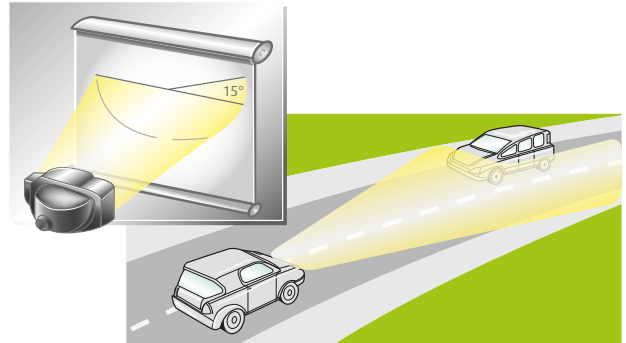

#### Low beam

- Must be orientated downwards.
- Must respect a cut-off line to avoid glazing the oncoming driver.

#### Right-hand traffic

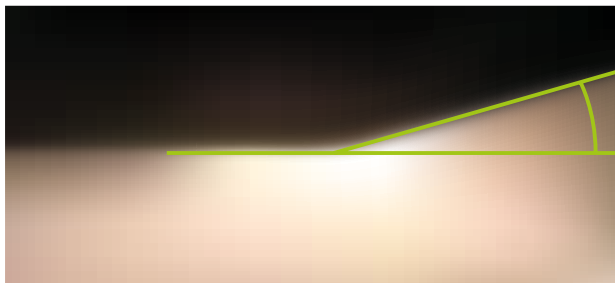

#### Left-hand traffic

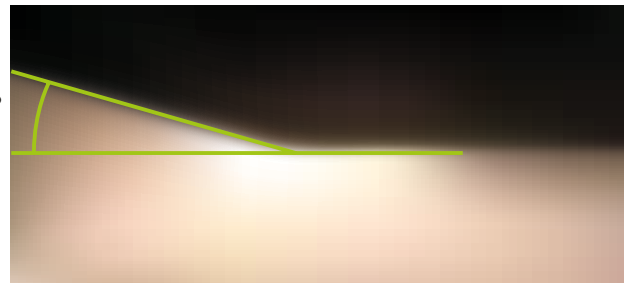

#### Fog beam

- Must respect a flat cut-off to avoid dazzling.

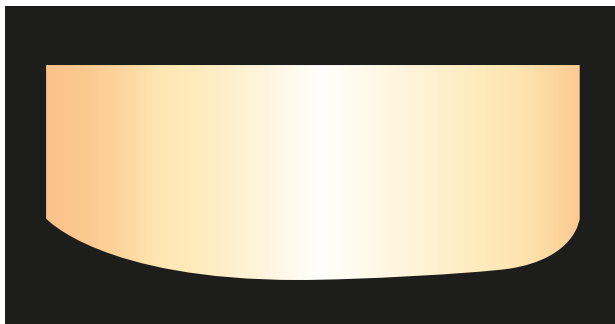

## 7.5. Beam's downward inclination

In addition to the cut-off line, lights must be set to a certain inclination angle, called the headlight aiming angle.

The aiming must be set to the appropriate point to ensure maximum illumination on the road without dazzling other road users.

This drawing represents the aiming angle setting for a passenger car, but the principle shown applies equally to vehicles of other categories.

### Initial aiming

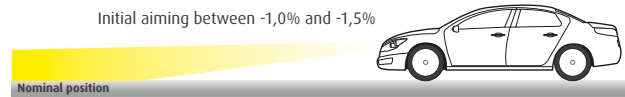

### Risk of dazzle

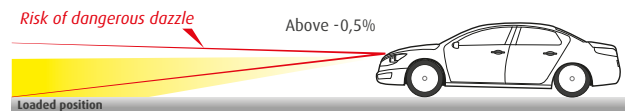

### Lack of visibility



The aiming is defined as follows:

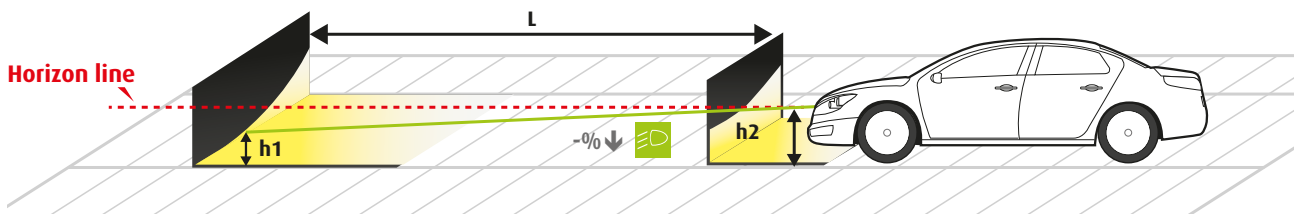

The inclination is expressed in percentage; it can be calculated by using the formula provided below. It measures light projected above the ground on a screen perpendicular to the vehicle axle at a distance of L=25 m.

$$\text{Inclination (\%)} = \frac{(h_1 - h_2)}{L} \times 100$$

The inclination is always a negative angle due to the light pointing downwards.

Where:

- **L** is the distance, in millimetres, from the screen to the projector centre of reference.
- **h1** is the cut-off line height above the ground, in millimetres, projected on the screen at a distance L.
- **h2** is the cut-off line height above the ground, taken at the projector centre of reference (eg. to a projection on the screen at a distance L=0).

## 7. Headlamps beams

### 7.5.1. Low beam inclination ranges

The value of the indicated downward inclination is defined below.

Depending on the mounting height of the light unit in metres (h) of the device, the vertical inclination of the cut-off must be between the following limits and the initial aiming have the following values:

- **$h < 0.8 \text{ m}$**

Limits: between -0.5% and -2.5%.

**Initial aiming:** between -1.0% and -1.5%.

- **$0.8 \text{ m} < h < 1.0 \text{ m}$**

Limits: between -0.5% and -2.5%.

**Initial aiming:** between -1.0% and -1.5%.

Or, at the discretion of the manufacturer.

Limits: between -1.0% and -3.0%.

Initial aiming: between -1.5% and -2.0%.

- **$h > 1.0 \text{ m}$**

Limits: between -1.0% and -3.0%.

**Initial aiming:** between -1.5% and -2.0%.

For category N3G (off-road) vehicles where the headlamps exceed a height of 1200 mm, the limits for the vertical inclination of the cut-off shall be between: -1.5% and -3.5%.

The initial aiming shall be set between: -2% and -2.5%.

### 7.5.2. High beam inclination ranges

For a front light with both low beam and high beam in the same reflector, the high beam will be aimed as it follows the low beam aiming.

If the high beam uses a separate reflector, the maximum high beam illuminance should be at 0° (horizontal line).

### 7.5.3. Fog light inclination ranges

- **$h \leq 0.8 \text{ m}$**

Limits: between -1.0% and -3.0%.

Initial aiming: between -1.5% and -2.0%.

- **$h > 0.8 \text{ m}$**

Limits: between -1.5% and -3.5%.

Initial aiming: between -2.0% and -2.5%.

## 7.6. Aiming setup and correction

We must distinguish two types of aiming: the so-called initial aiming and the aiming correction that must be performed according to the vehicle height variation (load, chassis dynamics).

### 7.6.1. Initial aiming

The initial downward inclination of the cut-off of the dipped beam is when the vehicle is unladen with one person in the driver's seat. It is specified within an accuracy of 0.1 per cent by the manufacturer and indicated in a clearly legible and indelible manner on all vehicles and will be near or on the headlamp or stamped on the manufacturer's plate using a standard, universal symbol.

#### Initial aiming manual setup



The initial aiming value is indicated on the headlamps. As a general rule, it must be set manually after fitment.

#### Initial aiming mechanism

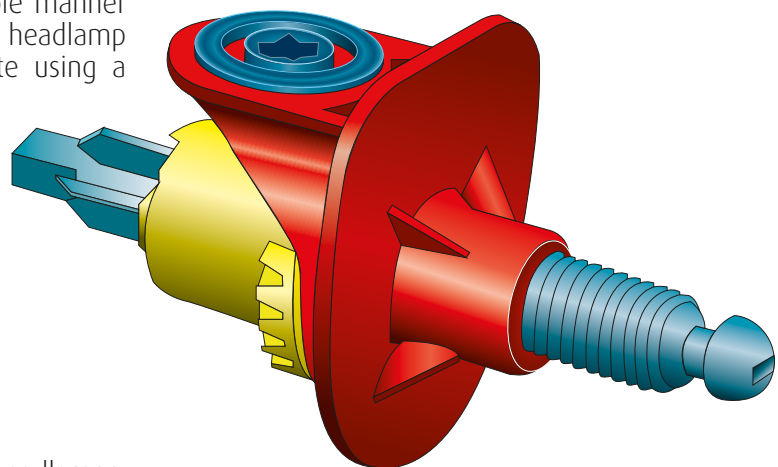

### 7.6.2. Aiming correction (levelling)

On top of the initial aiming of the low beam, vehicles must also comply with downward inclination of the low beam according to the load on the vehicle.

Levelling systems to compensate for load differences can be manual, electric or automatic.

#### Manual aiming used to set the initial aiming

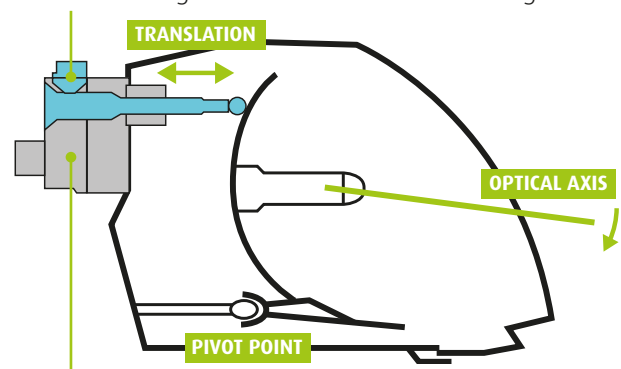

Motorized aiming used to adjust the correct position

# 7. Headlamps beams

## 7.6.3. Manual levelling

On manual levelling systems the number of settings will be determined to ensure the low beam has a downward inclination in all loading conditions.

The "0" position corresponds to the initial inclination, the following symbols are used to identify the controls.

On electric or automatically controlled beam levelling system, the aiming angle is adjusted with a device that integrates a DC motor.

The initial aiming can also be setup by using these controllers.



Initial aiming adjustment on the electrical actuator

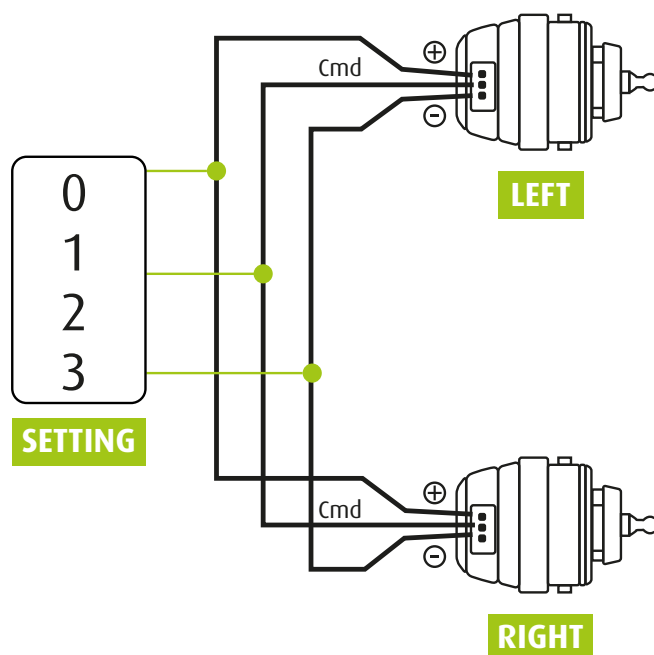



Headlamps applications with light sources exceeding 2000 lm per side require an automatic levelling system

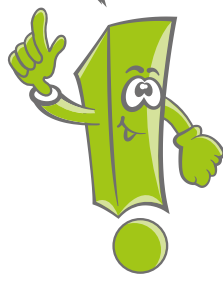

### 7.6.4. Automatic levelling

An automatic levelling system is mandatory for high luminance headlamps; it includes complementary sensors and one Electronic Control Unit that manages beams aiming according to the car load and chassis dynamics.

Automatic levelling diagram

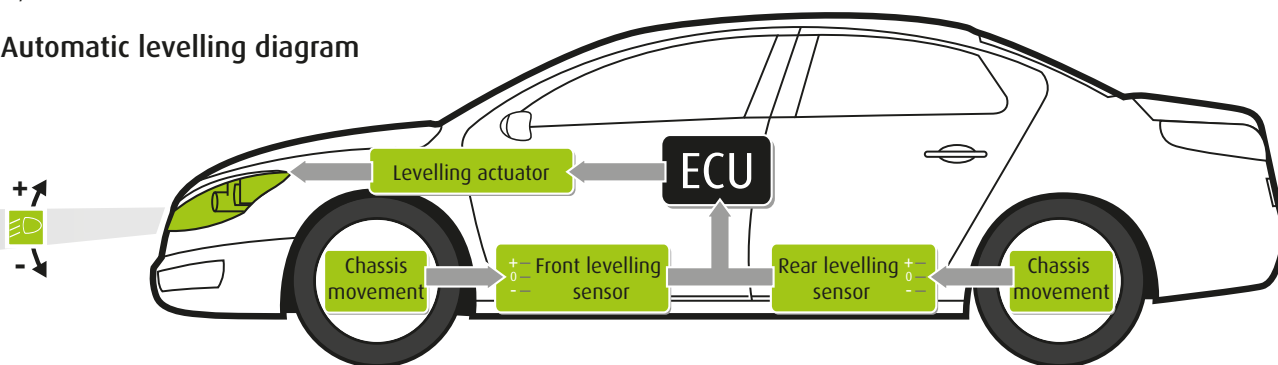

### 7.7. Headlamp fixation points

The headlight must be securely fixed on the vehicle to ensure stable lighting performance. All headlight mounting points must be in a good shape prior to setting any aiming values.

Check that no play occurs by controlling the headlight fixation points

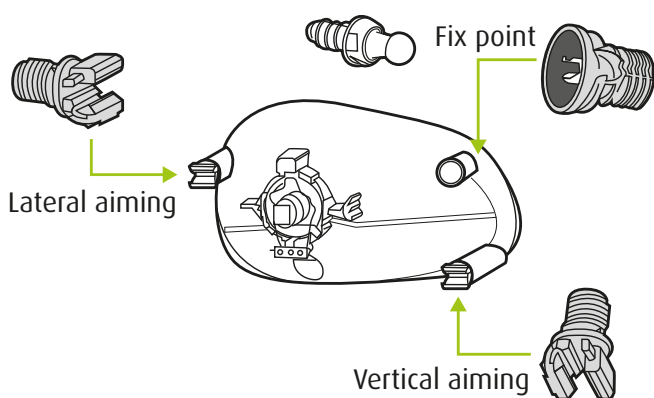
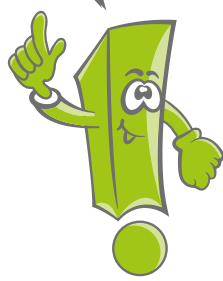

The aiming accuracy must be within 0.1%. Any broken parts on the mounting brackets strongly affect the light performance on the road and could possibly dazzle the other road users.

The headlight is equipped with both vertical and lateral aiming devices. All must be in a serviceable condition to properly set the beam pattern on the vehicle for the road.

# 8

## Beams photometric characteristics

The headlight projectors are components that must comply with optical regulations. Regulations define optical performance in several illuminated zones that are compiled in photometric charts.

Photometric charts have regular amendments and updates as lighting systems are developed and improved.

The aim is always to define illumination mapping according to:

- Road environments.
- Lighting technologies.
- Additional driving assistance features.

- 1 - Eye fixation
- 2 - Rear view mirror
- 3 - Posted panels (50 m)
- 4 - Posted panel (100 m)
- 5 - Opposers eyes (50 m)
- 6 - Road signs (50 m)
- 7 - Road signs (100 m)
- 8 - Pedestrians (50 m)
- 9 - Crash barriers (50 m)

### 8.1. What must be illuminated on the road?

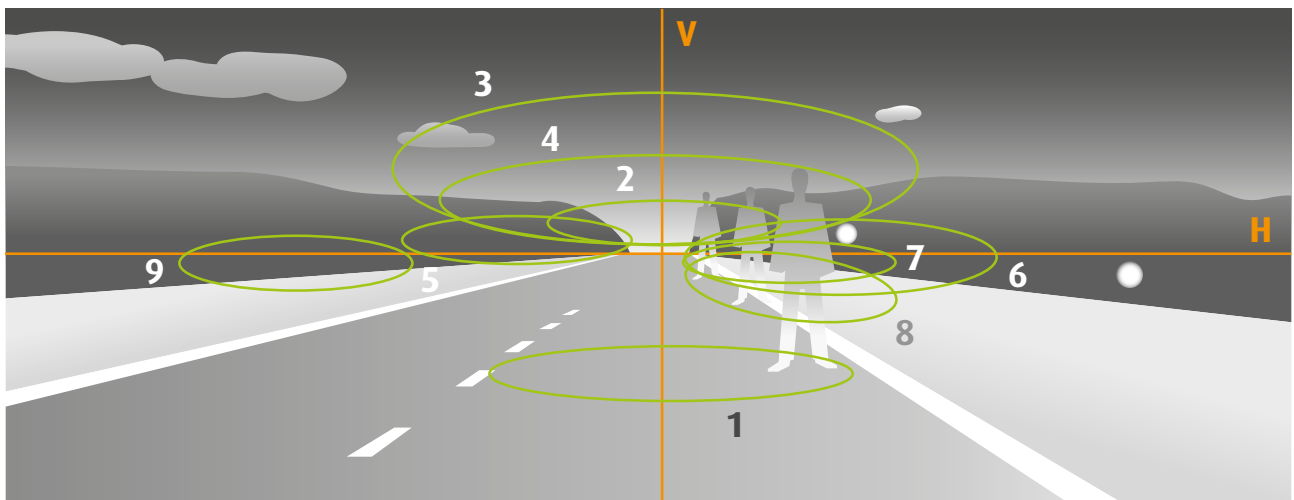

The **areas** to be illuminated or not in front of the vehicle and **their respective illuminance** levels are the basis of **photometric charts**.

## 8.2. Introduction to photometric specifications

Photometric specifications set illumination levels required on the road by defining photometric points and zones in the driver's field of view, from left to right at several distances.

The amount of points depends on the light source; Xenon lamps offers a wider beam so more points are required to specify the Xenon headlamps illumination pattern.

**Point or zones are associated to illuminance value limits (min. or max.) or their intensity (in candela).**

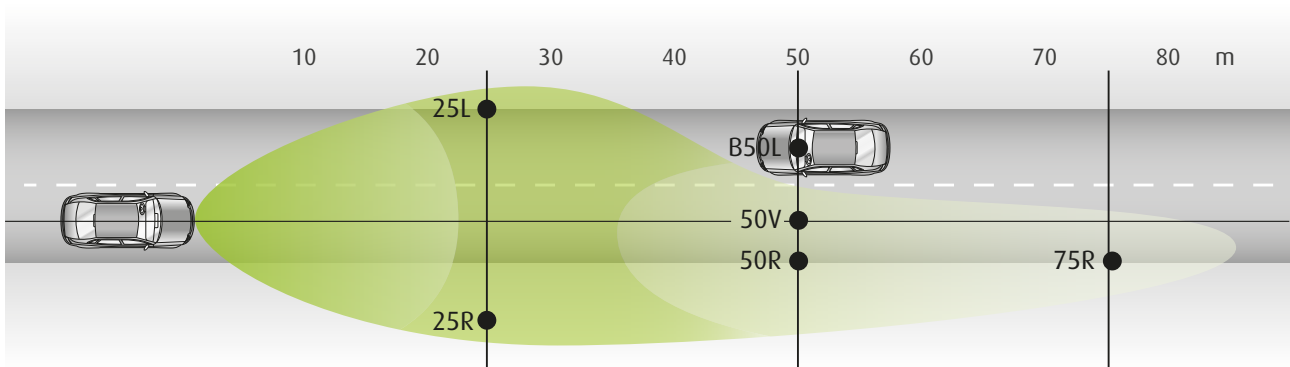

### ● 75R

Located at 75 m on the low **right** side.  
The value must be near to the maximum illumination  
It is the eye visual comfort point.

### ● 50R

Range point located at 50 m from the projector on the **right** side.

### ● 50V

Range point located at 50 m of the projector on the vehicle **vertical** path.

### ● B50L

Located at 50 m on the opposite driver glare trajectory (glare indication).

### ● 25L and 25R

Points located at 25 m from the projector on the far **left** and **right** edges.  
These two points give an indication on the beam width (low side road illumination).

# 8. Beams photometric characteristics

## 8.3. Photometric charts

In order to simplify control lighting systems specification, photometric charts have been standardized for each type of light source and have been updated according to systems evolution and complexity.

**Photometric charts are a 2D representation of light projection at 25 m on a flat vertical screen. This flat image reflects the real illumination on the road.**

The illumination mapping is defined via vertical and horizontal coordinates on a grid.

- Photometric points positioning is defined in terms of angular position.
- European regulation stipulates measurements at 25 m from the light source @ 13.2 V battery voltage.

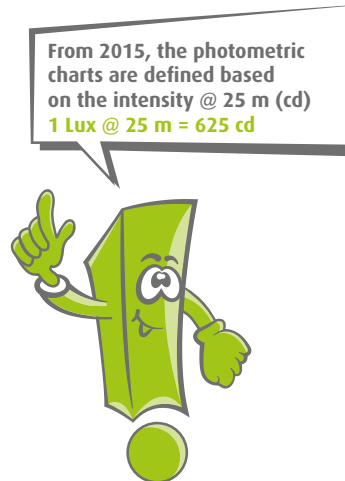

- Vehicles in Europe used to use the illuminance (in Lux) to characterize lighting systems. From 2015, the European commission harmonizes with US standards and defines the intensity (in candela) as the new unit for beams measuring. Nevertheless both illuminance and intensity units are linked and illuminance can still be used prior to the switch date.

### Low beam photometric charts for Halogen headlamps (ECE R112)

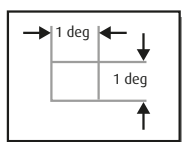
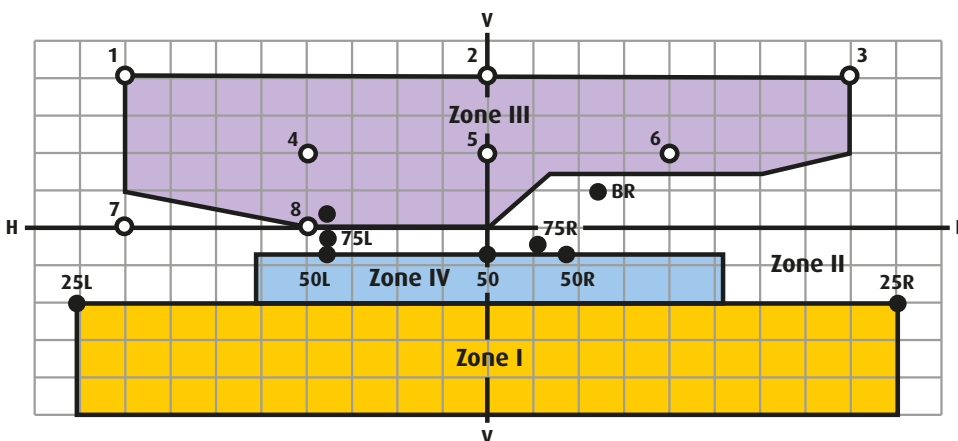

- Zone III < 625 cd
- Zone IV > 2500 cd
- Zone I < 50R or 50L

Zone II is delimited by line h-h, Zone I, Zone IV and vertical lines at 9 deg L and 9 deg R.

Halogen type	
I min. (cd)	I max. (cd)
B50L	- 350
75R	10100 -
75L	- 10600
50R	10100 -
50L	- 13200
50V	5100 -
25L	1700
25R	1700 -
P1	190 -
P2	190 -
P3	190 -
P4	375 -
P5	375 -
P6	375 -
P7	65 -
P8	125 -

As a summary:

- **The cut-off line is part of the chart and it is a major point to comply with.**
- Complementary points are defined to ensure no oncoming vehicles glare issues.
- 3 zones are set with min. and max. illumination limits.

### 8.3.1. Photometric charts depend on light sources

Whatever the light source, photometric points are used to set limits to lighting systems in order to reach the appropriate comfort and security levels when driving at night.

Halogen lamps cannot perform as well as Xenon lamps. Light source performances are taken into account in lighting system regulations and dedicated regulations apply to each light source application.

- Halogen and LED sources: ECE R112.
- Xenon: ECE R98.

### 8.3.2. Photometric charts by country

Automotive regulations are driven by:

- The UNECE - United Nations Economic Commission for Europe.
- The SAE International - Society of Automotive Engineers.
- The JSAE - Society of Automotive Engineers of Japan.
- The JASO - Japanese Automotive Standards Organization.

Lighting regulations for the United States, Canada, and Mexico (NAFTA) markets differ on some points for beams photometric charts but the basics are very similar and the aim is always to improve visibility and safety on the road.

Automotive lighting systems nevertheless tend to be more and more global for an increased efficiency in car design and to ensure the vehicle can be marketed globally.



# The bright idea: the right Valeo bulb for each driver's need

For each vehicle entering in the workshop, a compulsory check allows to detect defective bulbs. With Valeo, your Lighting Systems specialist, you can propose the right bulb to each driver's profile.

## Your customer wants...

... to maintain the original lighting performance

... to drive with comfort & style

... to get optimal bulb durability

... to drive regularly on motorways

... to drive frequently with bad weather conditions

### ESSENTIAL

→ Provide the Valeo original quality



### BLUE EFFECT

→ Blue tinted light, Xenon effect-like



### LIFE x2

→ Highly resistant bulb with doubled lifetime vs. Essential



### +50% LIGHT

→ Up to +50% lighting intensity for improved visibility



### AQUA VISION

→ Avoid dazzling effect with rain, snow & fog with a specific glass coating



	★★★★☆	★★★★☆	★★★★☆	★★★★★	★★★★☆	
	★★★★☆	★★★★☆	★★★★☆	★★★★★	★★★★☆	
	★★★★☆	★★★★☆	★★★★☆	★★★★☆	★★★★☆	

Signalling bulbs x2 available in P21W, PY21W, P21/4W, P21/SW, R5W, R10W.

Signalling bulbs x10 available in C5W, P21W, PY21W, P21/4W, P21/SW, R5W, R10W, 14W, W3W, W5W, WY5W, W16W.

Halogen bulbs x1 available in H1, H3, H4, H7, H9, HB3, HB4, HR2, H8, H27/W1, H27/W2.

Signalling bulbs x10 available in T4W, W5W.

Halogen bulbs x1 available in H1, H4, H7, HB3, HB4.

Halogen bulbs x1 available in H1, H4, H7, H11.

Halogen bulbs x1 available in H1, H4, H7.

Halogen bulbs x1 available in H1, H4, H7.

ACCESS THE VALEO BULB CATALOGUE TO FIND THE RIGHT REFERENCE



# 9

## From Halogen to Xenon front lighting

As already discussed, the human eye perception depends on the light colour; today's projectors are fitted with three types of light sources.

- Incandescent lamps (Halogen).
- Gas discharge lamps (Xenon).
- LED lamps.

Light sources technologies differ in many points.

- Light colour is different.
- Luminous flux is different (lumens).
- Intensity is different (candela).
- Luminance is different (candela/m<sup>2</sup>).

All this leads to a huge light projection difference on the road, as illustrated by the following illuminance curves, so-called "isolux" curves.

Halogen - Illuminance isolux curve

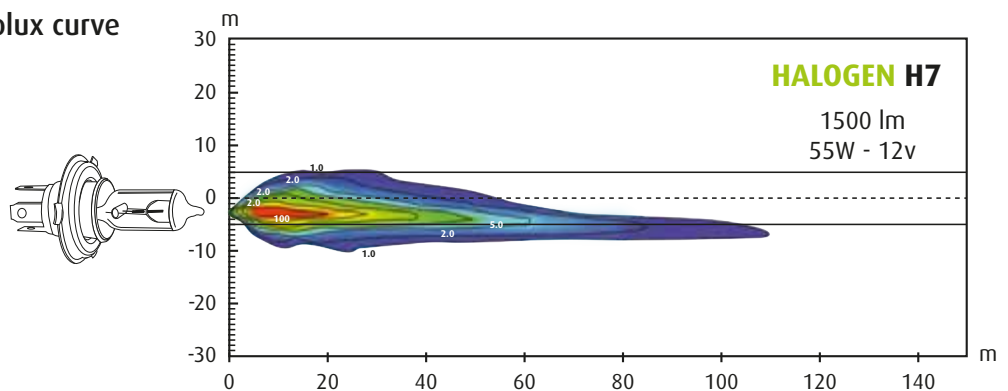

Xenon - Illuminance isolux curve

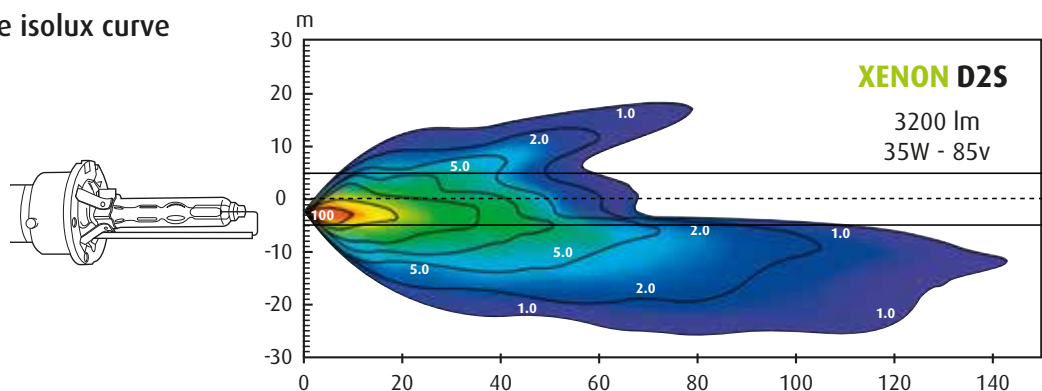

As Xenon lamps produce a larger light projection, the Xenon regulation (ECE-R98) defines more photometric points than the Halogen lamp regulation (ECE-R112) to characterize the system performances.

# 10

## Halogen lamps

The Halogen technology is an improvement of the historical tungsten incandescent lamps. It is widely used in automotive applications for lighting and signalling.

Compared to their Tungsten predecessors, Halogen bulbs are not sensitive to “blackening of the light bulb glass”. Halogen bulbs stay clear, achieving a longer service life.

### 10.1. Halogen regenerative cycle

The combination of the Halogen gas and the tungsten filament produces a regenerative reaction which deposits evaporated tungsten back onto the filament, increasing its life and maintaining the clarity of the bulb glass for a higher luminous efficiency.

#### The Halogen regenerative cycle

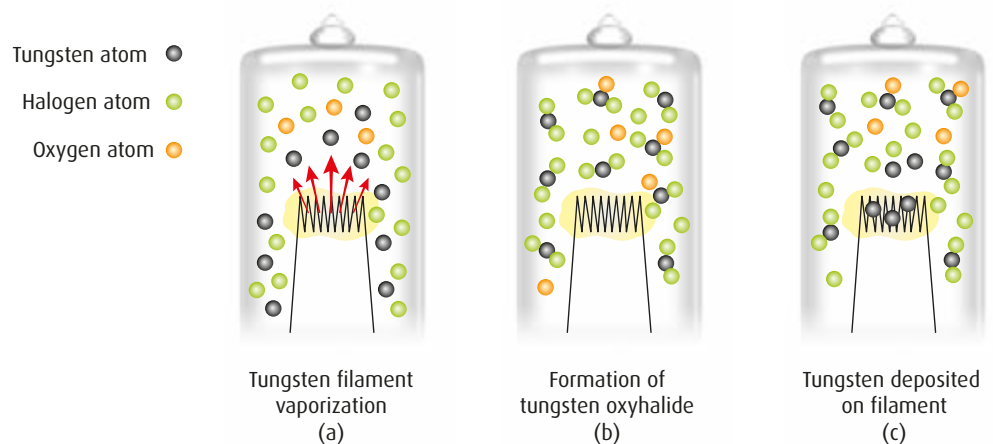

The strong quartz envelope enables higher internal gas pressures to be used to avoid filament vaporization.

This allows increased filament temperatures that produce a higher luminous output, it modifies as well the light colour profiles to feature more desirable visible wavelengths.

As a result, Tungsten-Halogen lamps retain their original brightness throughout their life span and also convert electric power to light more efficiently than their Tungsten lamps predecessors.

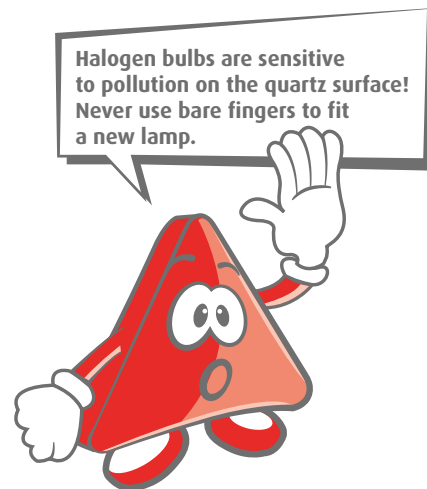

Halogen lamps should never be touched with bare fingers, since oils and other residue can damage the quartz envelope and lead to premature lamp failure. Prior to operating the lamp, any fingerprint must be removed.

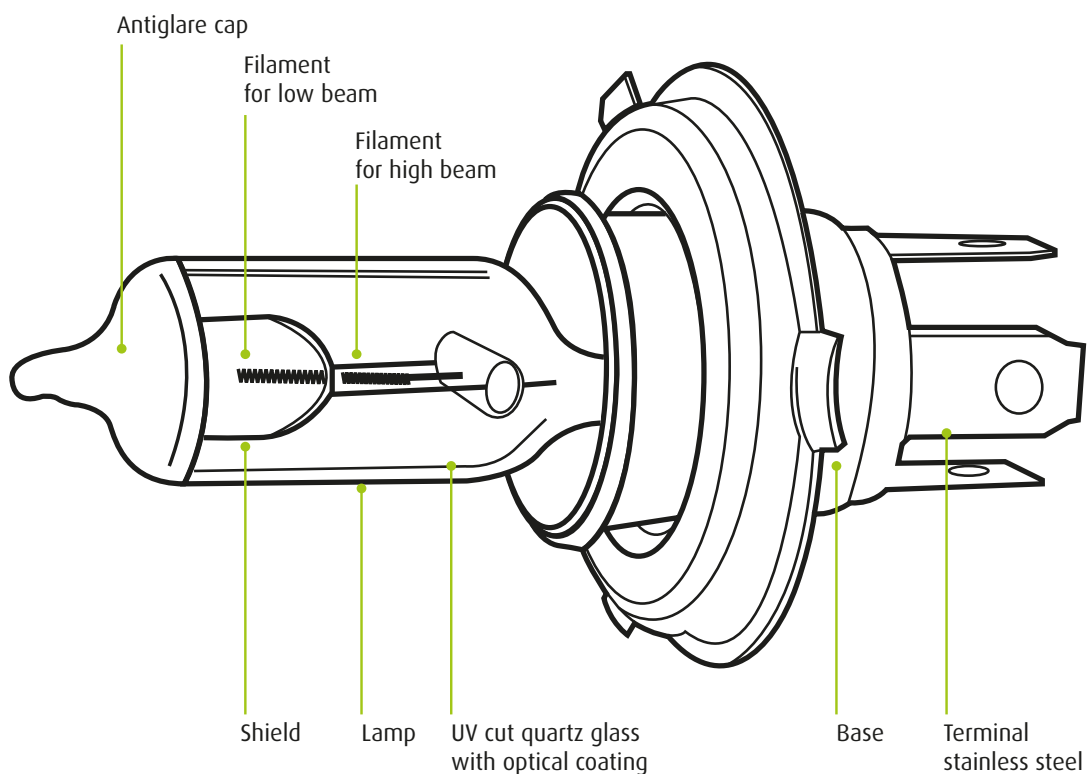

# 1

## Gas-discharge lamps

In gas-discharge lamps the radiated light output is derived from a plasma arc discharge within an arc tube.

Gas-discharge lamps do not have a filament as used in a Halogen lamp. Instead an arc is created between two electrodes in a quartz bulb which is filled with a mixture of noble gases and metal halide salts.

### Wire element of a Halogen lamp

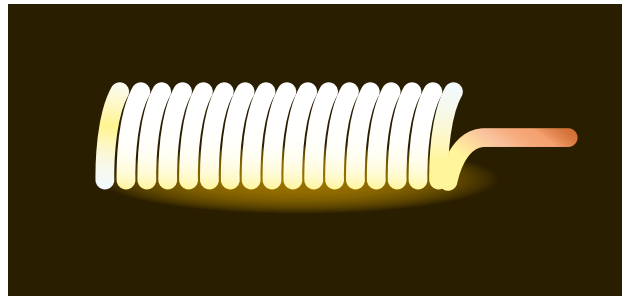

### Light arc of a Xenon lamp

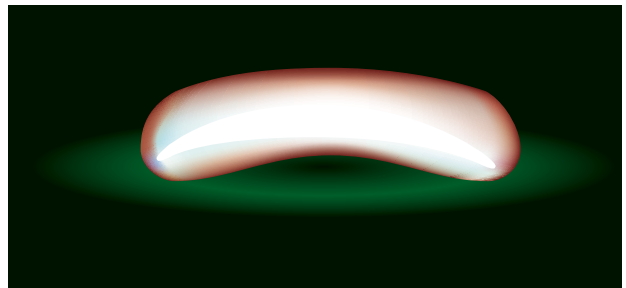

## The arc tube

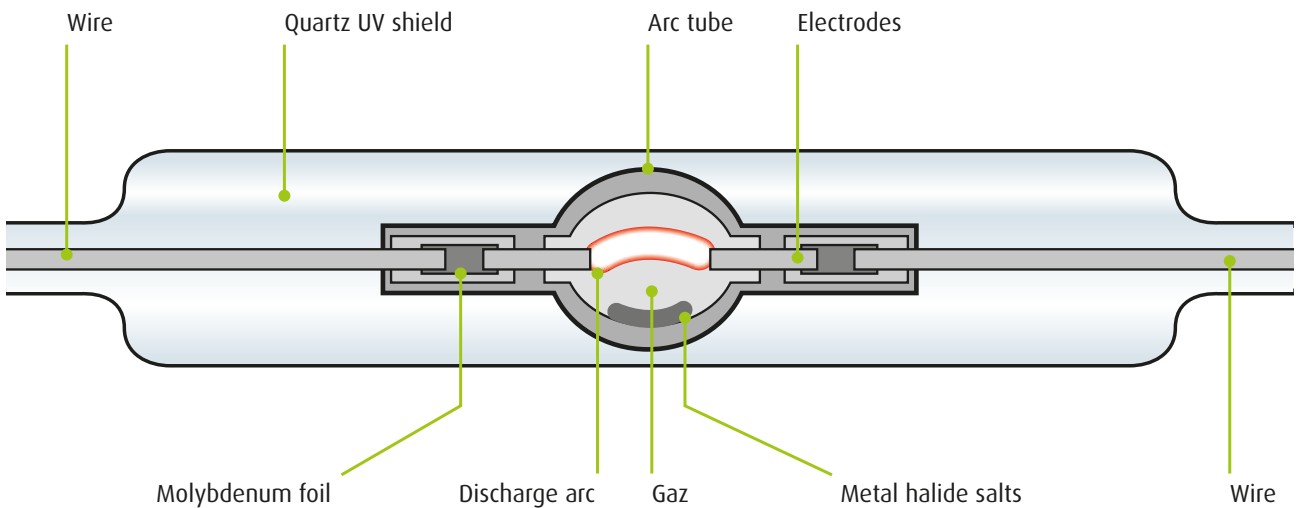

The performance of the gas discharge lamp depends on the pressure of the gas as well as the frequency of the electrical stimulus. Such lamps use gases like Argon, Neon, Krypton, Xenon or possibly a blend.

Each gas, depending on its atomic structure emits certain wavelengths which translate in different colours of the lamp.

Gas-discharge lamps offer high efficiencies and a longer life. However, they are more complex and require more electronics, such as ballasts devices to control them.



# 11. Gas-discharge lamps

## 11.1. Xenon lamps structure

High Intensity Discharge lamps (HID) are also known as Xenon lamps. They belong to the high pressure discharge lamp family.

The arc within HID bulbs generates ultraviolet (UV) light; a UV-absorbing glass shield is incorporated around the bulb's arc tube to prevent degradation of UV-sensitive components and materials. In headlamps these components are polycarbonate lenses and reflector coatings.

### D2R Type bulb

Similar to H4 Halogen lamps, D2R use a "cut-off shield".

### D2R Xenon lamp structure

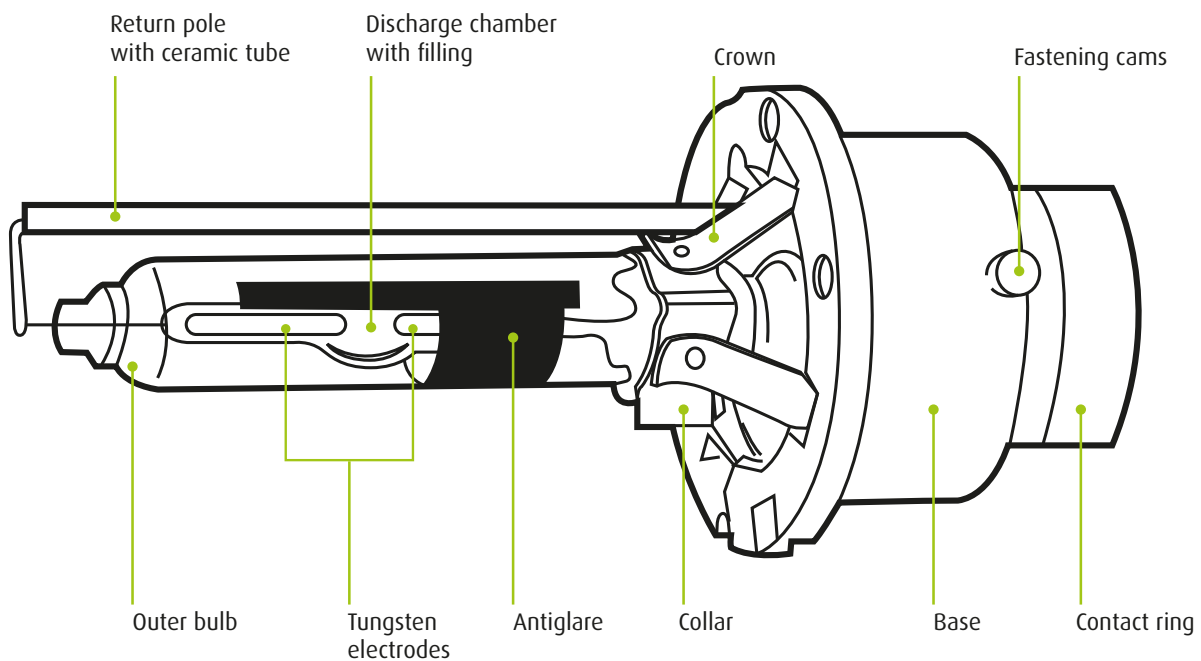



### 11.1.1. Xenon, a discharge lamp tuned to automotive applications



Automotive HID's can be called "Xenon headlamps", but they are actually metal-halide lamps that contain Xenon gas.

#### The right spectral distribution

One of the most important parameters to take into account in selecting a light source is the spectral distribution (or wavelength profile) emitted by the source.

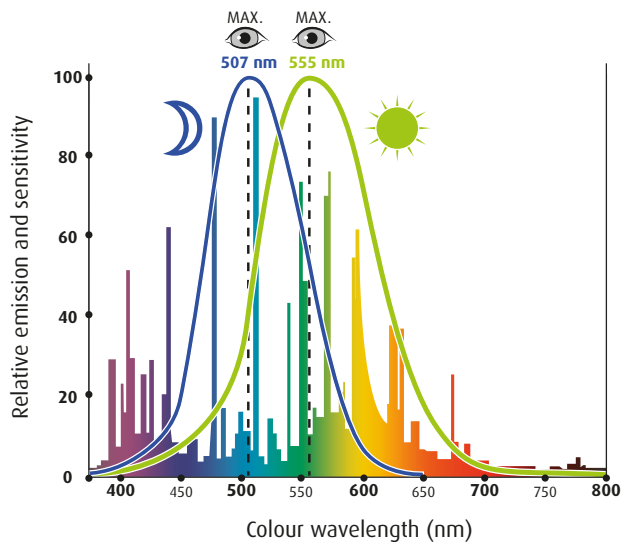
The light spectrum produced by the Xenon lamps is optimized to maximize human eye visual perception.



-  Xenon spectral power distribution
-  Human vision photopic sensitivity (day light adapted)
-  Human vision scotopic sensitivity (night adapted)

The regulation ECE R99 specifies Xenon colour tolerance on the chromaticity grid, the colour objective is  $x = 0.375$  and  $y = 0.375$ . The tolerances on the graph correspond to a range between 4000 K and 5000 K; when comparing the colour temperature of Tungsten-Halogen lamps, it varies from 3000 K to 3550 K.

Lower colour-temperatures exhibit a higher red rendering and higher temperatures exhibit a blue rendering.

#### Halogen and Xenon positioning

CIE 1931  $x, y$  chromaticity diagram

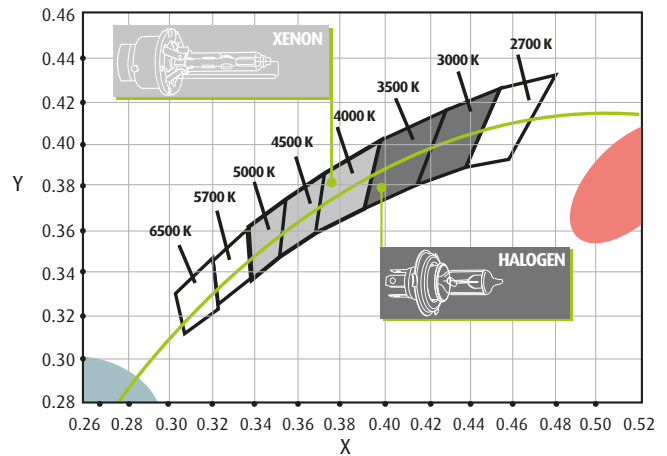

# 11. Gas-discharge lamps



*The Halogen high beam is reddish.*



*The Xenon high beam is bluish.*

## A limited warm-up time

Different noble gasses have different start up times. Argon gas, for example causes metal-halide lamp applications to take several minutes to reach their full output. **Xenon gas allows lamps to produce an adequate light immediately upon start-up and has a short time-span to reach full power.**

To comply with ECE R99, Xenon lamps must exhibit 80 per cent of their total luminous flux 4 seconds after start-up.

In addition to the short start up time, the use of Xenon gas allows the complete colour emission profile (light spectrum) upon ignition.

## A high light output

Dirty headlamps produce a diffused light output and cause glare to oncoming traffic. Whereas this phenomenon is not exclusive to Xenon lamps, the dazzling effect from Xenon is much higher and not acceptable.

**Most of Xenon headlamps exceed 2000 lm each,** they require automatic levelling devices.

For European applications, Xenon systems require a high pressure cleaning device to avoid any dirt from affecting the visibility of other road users.

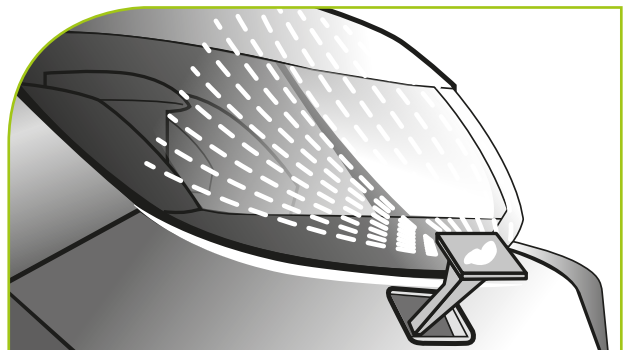

## 11.2. Xenon system operation

HID headlamp bulbs cannot operate on a low-voltage direct current, so they require a ballast system with an igniter. The igniter may be either internal or external to the lamp.

The igniter is integrated into the bulb in D1 and D3 systems, and is a separate unit or part of the ballast in D2 and D4 systems. **The ballast controls the ignition voltage and current to the bulb.**

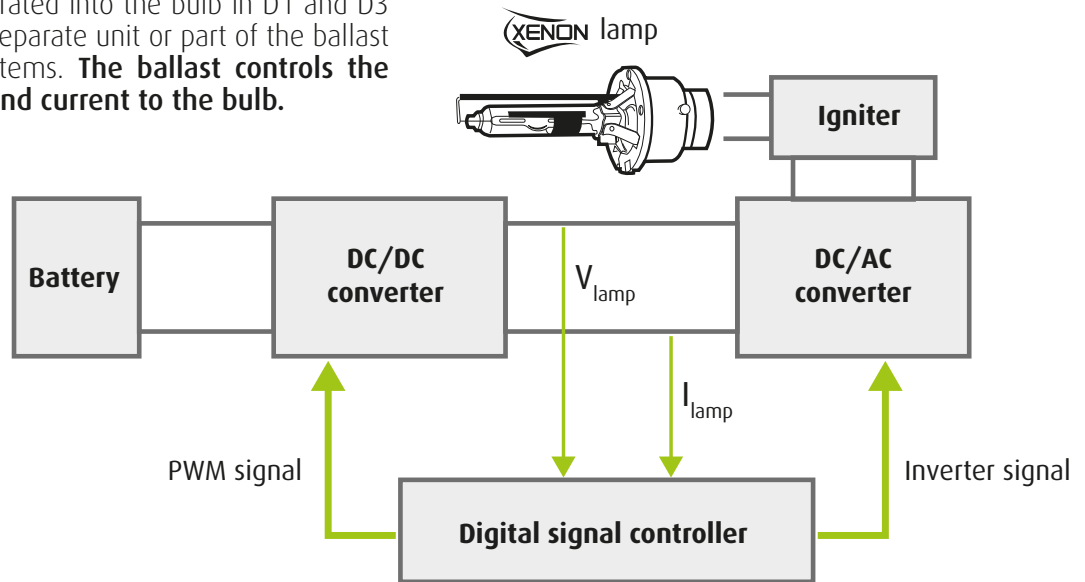

The start-up process of automotive HID lamps is quite complex. The diagram below shows the voltage and current of a HID lamp from power-on to steady state.

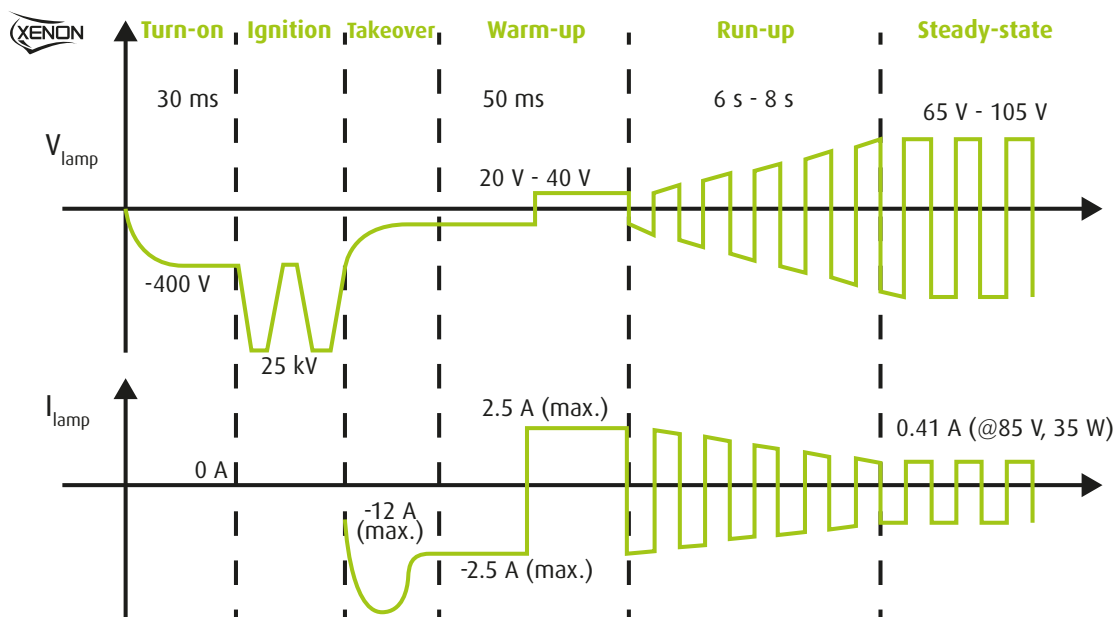

# 11. Gas-discharge lamps

The ignition and ballast operation proceeds in several stages:

## 1. Turn-on

Before ignition, the lamp's equivalent impedance (resistance) is considered as infinite. In this stage, the voltage generated by the ballast is fed to ignite the lamp.

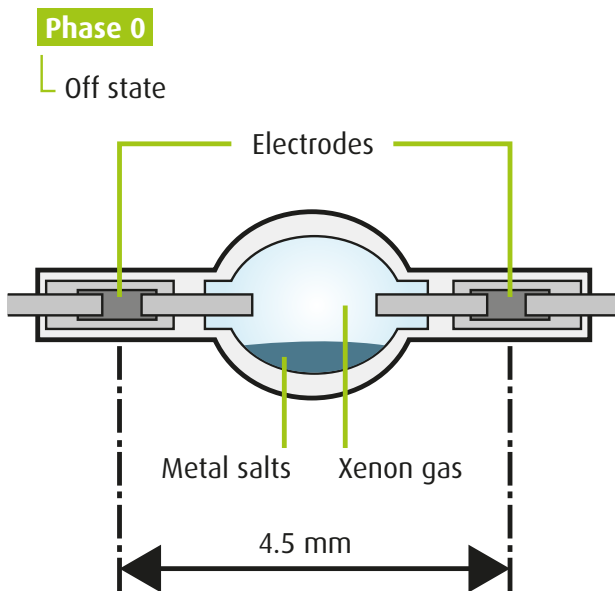

Before ignition, the operation frequency is 1 kHz.

## 2. Ignition

During this stage, the ignition circuitry generates a high voltage pulse across the lamp, as a result an arc is established in the tube and visible light is generated.

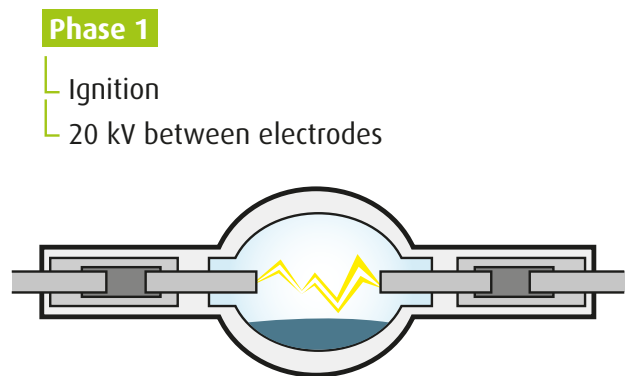

The required ignition voltage for a lamp when it is cold is around 10 kV. For a lamp when it is hot the voltage is around 25 kV.

A conducting tunnel between the Tungsten electrodes is created and current flows between the electrodes.

**Initial phase/take over:** After successful ignition, the lamp requires a large current (takeover current) to sustain the arc. Because the arc is operated at high power, **the temperature in the capsule rises quickly. The metallic salts vaporize;** the arc is intensified and made spectrally more complete. The resistance between the electrodes also falls; the electronic ballast control unit registers this and automatically switches to continuous operation.

After ignition and take-over, the operating frequency is switched to 20 Hz for the warm up stage.

#### Phase 2

- └ Heating
- └ Salts evaporation
- └ Maximum intensity (I)

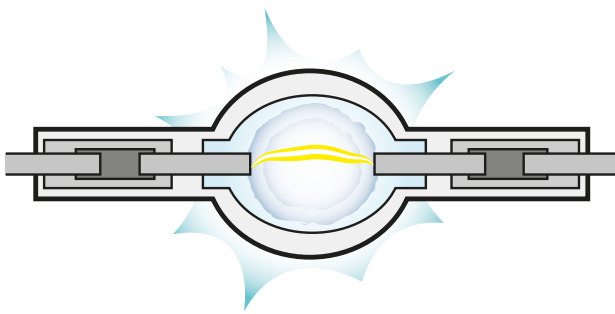

### 3. Warm-up

In this stage, the DC/DC (direct current) converter provides a certain amount of current, depending on the lamp condition to sustain the arc. The converter works as current mode, and generates a square wave AC current (alternating current). As the frequency is low (20 Hz) when compared to the steady state frequency, it's also called DC status.

When the warm-up stage is over, the inverter operates at 200 Hz.

### 4. Run-up

This is the key stage of the start-up process. In order to meet the R99 regulation, the start transient power during the run-up is higher than the expected steady state level; the ballast then controls the lamp power to ramp down to the normal level.

### 5. Steady state

In steady state, all metal crystals are vaporised and the arc has attained its stable shape, meaning the luminous efficiency has reached its nominal value. The ballast is now supplying stable electrical power so the arc will not flicker. Stable operating voltage is 85 volts AC in D1 and D2 systems, 42 volts AC in mercury-free D3 and D4 systems. The frequency of the square-wave alternating current is typically 400 hertz or higher.

#### Phase 3

- └ Light emission
- └ 3200 lumens - 35 W

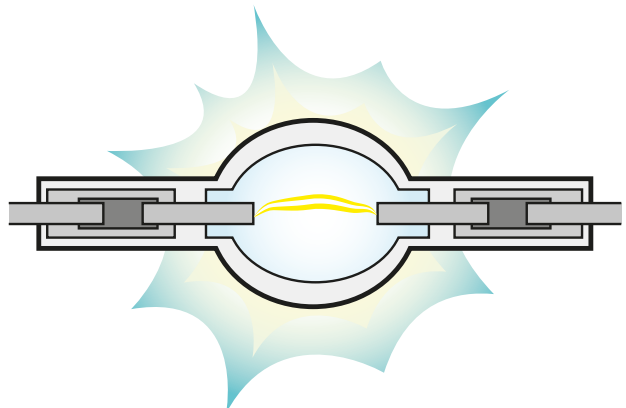

# 11. Gas-discharge lamps

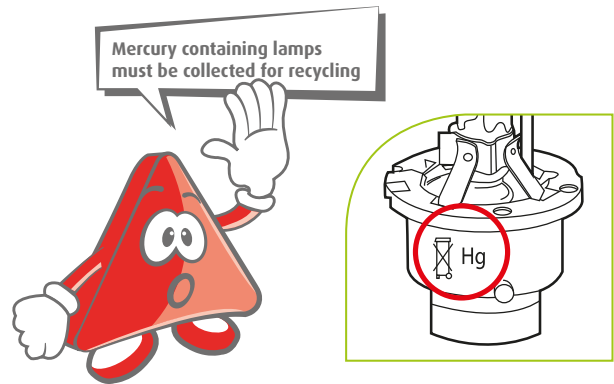

## 11.3. Xenon lamp types and numbering

Since the very first applications for automotive in the 90's, Xenon lamps have been shared between elliptical projection-type headlamps and reflection-type headlamp, both types do not use the same lamps because of the cut-off pattern. Depending on their generation, Xenon lamps may integer as well the so-called ignitor (a high voltage pulse-transformer). As the ignitor is part of this module it is changed systematically in case of lamp failure.

Complementary to this diversity, an Hg-free range has been introduced to comply with new regulations. **D4, D6 lamps and D3, D5, D8 modules are mercury-free devices (Hg).**

Mercury-free types are not interchangeable with mercury containing types. Lamps connective systems are regulated by coding types that avoid mistake as interchangeability is not possible.

Current-production of Xenon lamps are D1S, D1R, D2S, D2R, D3S, D3R, D4S, D4R, D5S, D6S, D8S.

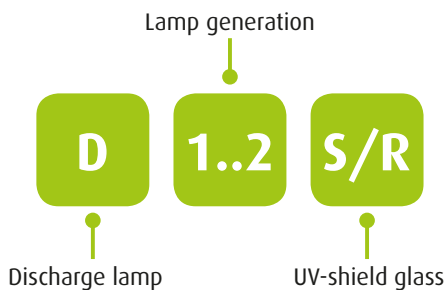

- The D stands for discharge lamp.
- The number is the lamp generation.
- The final letter describes the outer UV-shield glass.

## S -Types

D1S, D2S, D3S, and D4S have a plain UV-shield-glass and are primarily used in projector-type optics.

In S-Type-lamp applications the light cut-off is created by a mechanical shield in the optical system.

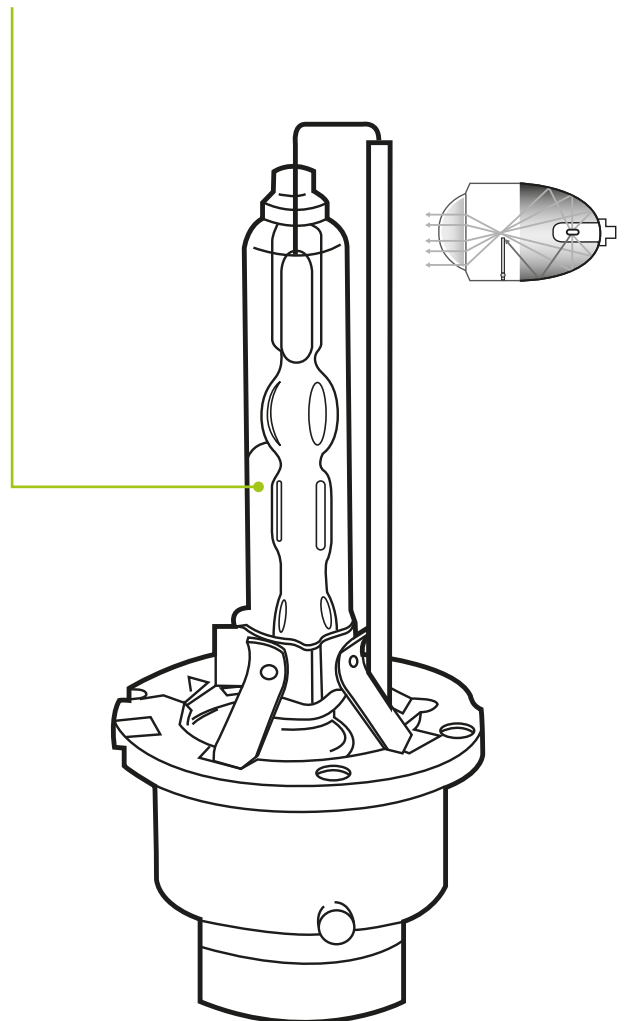

## R - Types

D1R, D2R, D3R, and D4R are designed for use in reflector-type headlamp optics. They have an opaque mask covering specific zones of the UV-shield for the low beam cut-off creation.

To generate the cut-off line in the light distribution, a black coating is applied directly on the outer bulb of the lamp.

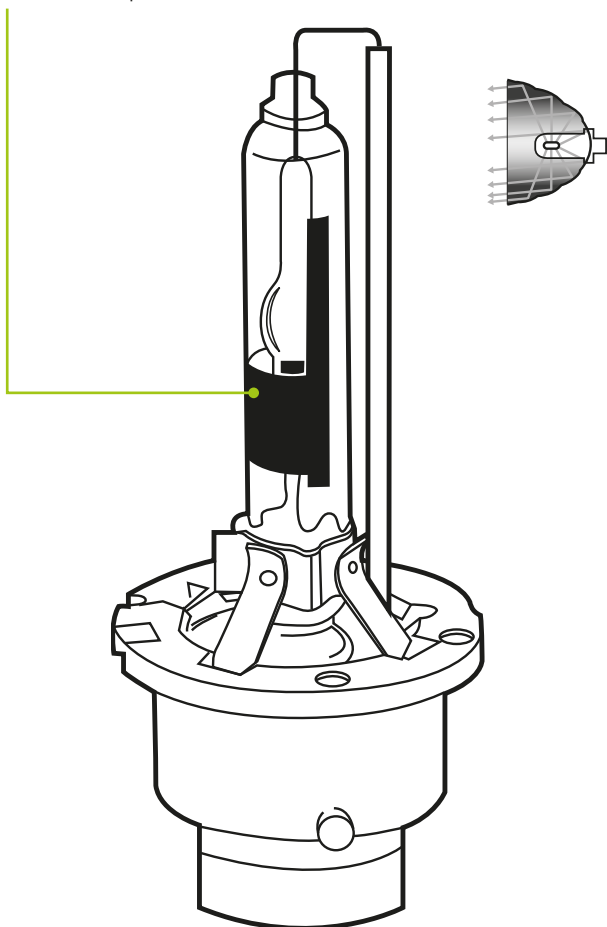

### 11.3.1. D6S / D8S to democratise Xenon lamp

D6S and D8S belong to a new category of gas discharge light source with the latest, high efficiency, mercury-free technology.

#### D6S / D8S (module) lamps:

- Mercury-free.
- 25 W instead of conventional 35 W for HID lamps.
- Luminous flux 2000 lm.

**With a limited light flux of 2000 lumens, headlamp washers and automatic levelling systems are no longer mandatory. This allows implementation of HID systems on more mainstream vehicles.**

### 11.3.2. D5S a fully integrated Xenon lamp

The D5S was the first fully integrated Xenon lamp. Automotive lamp manufacturers have managed to combine in one case the ballast and the ignitor unit. This has simplified the system and avoids using high voltage harnesses.

#### D5S lamp features:

- Mercury-free.
- Direct 12 v power supply.
- No high voltage cable.
- 25 W instead of conventional 35 W for HID lamps.
- Luminous flux 2000 lm.

**As for the D6S and D8S, the D5S applications do not require headlight washers and automatic levelling correction.**



# 12

## Light source positioning

Whatever the type of source, the position of the light source is key to headlamp performance.

**Illumination on the road is the projection of a light source via an optical device, hence the position of the light source can make a huge difference on the final photometric results.**

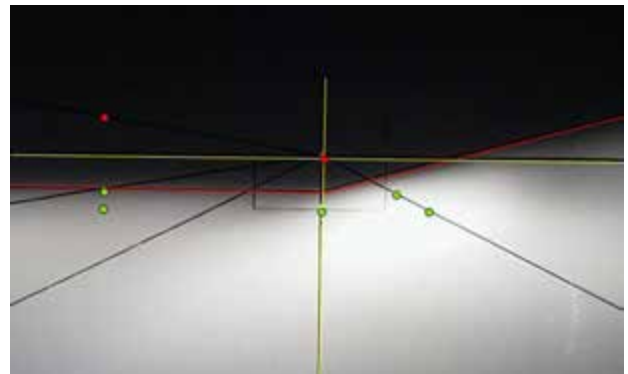

If we take the particular case of a filament, its precise positioning inside the lamps is the first mandatory feature to comply with. The filament size and positioning versus the lamp axis and lamp reference plane are both specified in R37 and R99 regulations.

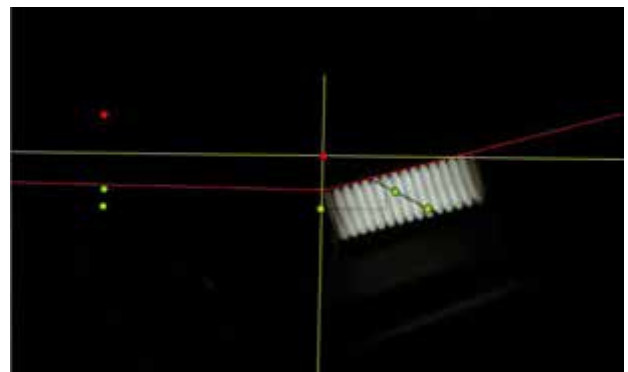
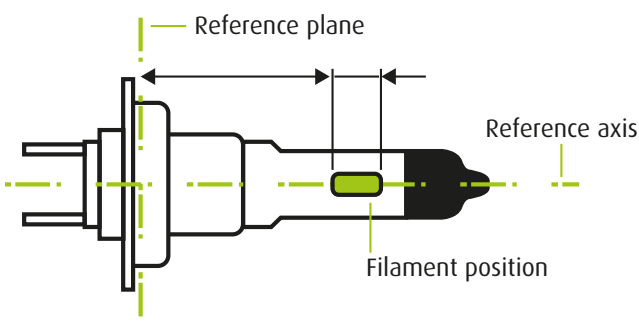

# 13

## High and low beams optical systems

Whatever the optical design, it must include the appropriate apparatus to:

- Properly position the light source
- Generate the cut-off
- Avoid glare
- Comply with photometric points
- Manage high and low beam switch-over
- Manage levelling angle



*Valeo headlamp for Opel / Vauxhall Corsa D with Halogen-type Dynamic Bending Light system.*

The optical design on high and low beams depends on the headlamp generation as well as projector dimension constraints. There are three technologies used to create low and high beams: parabolic reflectors, complex surface reflectors and elliptic modules.

# 13. High and low beams optical systems

## 13.1. Parabolic type

In many parabolic reflector designs, both high and low beam are produced in a single reflector using a dual filament lamp.

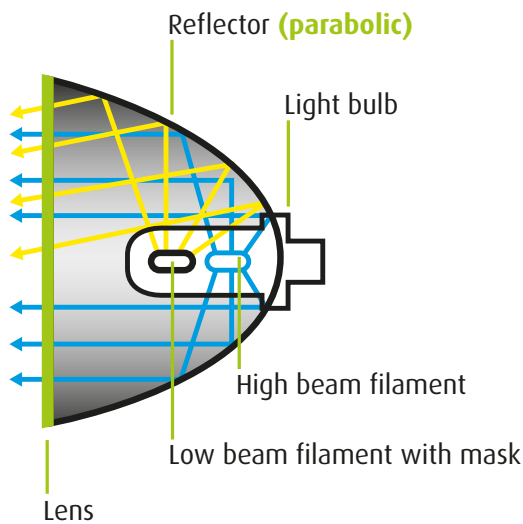

The European way of achieving low and high beam from a single bulb involves two filaments along the same axis in the reflector (typically H4 lamps).

To avoid glare, some additions must be made for the low beam. A shield is fitted in the lamp to prevent direct light rays from striking the lower half of the reflector and be reflected upward through the headlight lens, causing glare to other road users. The shape and angular position of the shield defines the cut-off projected pattern.

The light-spread on the road is then achieved by patterns in the glass on the outer lens.

**More than 40% of the energy produced by the H4 bulb is lost by covering the bulb with this shield.**

### Parabolic reflector type - H4 low beam filament



Parabolic reflectors were basically used in Europe with dual filament H4 lamps.

<b>OPEL</b> (.....)			
<b>Corsa B (93&gt;2000)</b>			
03/1993 → 08/2000			
		M   HC/R   H4   CTL	<b>085132</b> <b>085133</b> 1216488 1216489
		E   HC/R   H4   CTL	<b>085134</b> <b>085135</b> 1216486 1216487

Headlamp for Opel / Vauxhall - Corsa with H4 lamp and parabolic technology

<b>085132</b>	<b>085133</b>
1216488	1216489
<b>085134</b>	<b>085135</b>
1216486	1216487

## 13.2. Complex-surface type

Complex surface technologies were a major step in projector efficiency. They allow the use of all of the light produced by the bulb to create the low beam. The first generation became available in the 90's but still used patterned glass on the outer lens. The second generation of complex surface technology allowed using clear plastic lenses.

**Since then, the cut-off, horizontal spread and homogeneity of the light beam are entirely performed by reflectors and their shapes.**

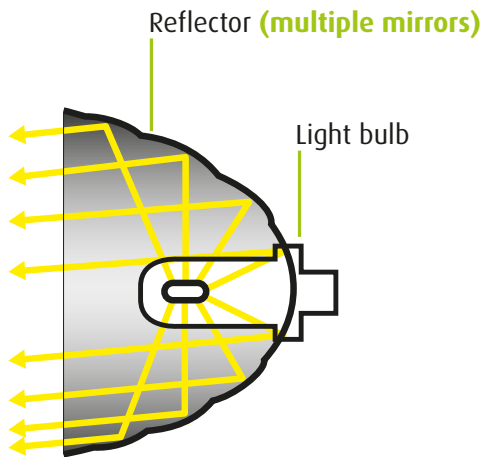

Complex surfaces are used for any beam and any light source.

Peugeot	207 (2006>)	03/2006→	E*	HCHR	H7+H1	CTL	043238	043239
			620895	620695				

Headlamp for Peugeot - 207 with H7+H1 lamps and complex surface technology

**043238 043239**  
620895 620695



Complex-surface reflector

Complex surface reflectors are a very common design on headlamps. They consist of a multitude of small reflecting surfaces that produce the appropriate illumination pattern on the road.

As a general rule any type of light source can be used, from Halogen to Xenon and increasingly more common, LED.

Complex surface reflectors are designed using intricate optic simulation. They offer better design flexibility (height reduction) and a much higher efficiency when compared to parabolic type light units.

## 13.3. Complex-surface and Xenon lamps

Low beams based on Xenon reflector-type lamps do exist, such designs must use special bulbs (R types).

In this particular case the cut-off pattern is achieved by combining complex surface reflections and an opaque coating shield that is printed on the outer glass of the lamps.

Renault	Laguna II (2001>2005)	01/2001→02/2005	VEH	DCHR	D2R+H1	CTL	088319	088320
			7701474502	7701474501				

Headlamp for Renault - Laguna II with D2R+H1 lamps and complex surface technology

**088319 088320**  
7701474502 7701474501

# 13. High and low beams optical systems

## 13.4. Glare management in reflector-type optics

In addition to using a cut-off pattern, light can also be prevented from leaving the end of the light bulb. This is achieved on Halogen lamps by using an opaque coating that caps the end of the bulb.

### H4 Halogen opaque glare-shield

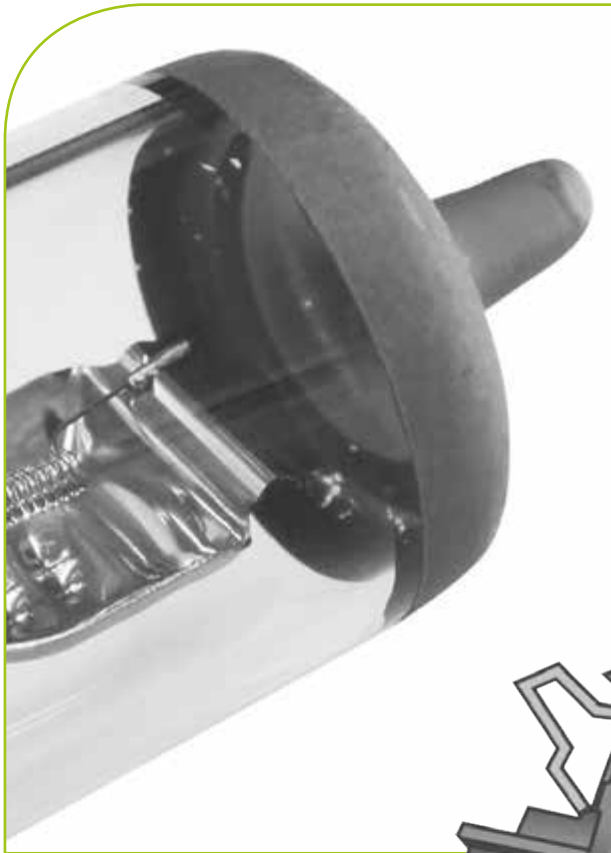

### Xenon external glare-shield



Some reflector-type applications require an external metal shield.

- This is mandatory for Xenon lamps.
- In some cases, it can be used to meet photometric regulations.
- It can also help in reducing temperature on the bezel.

### Halogen external glare-shield

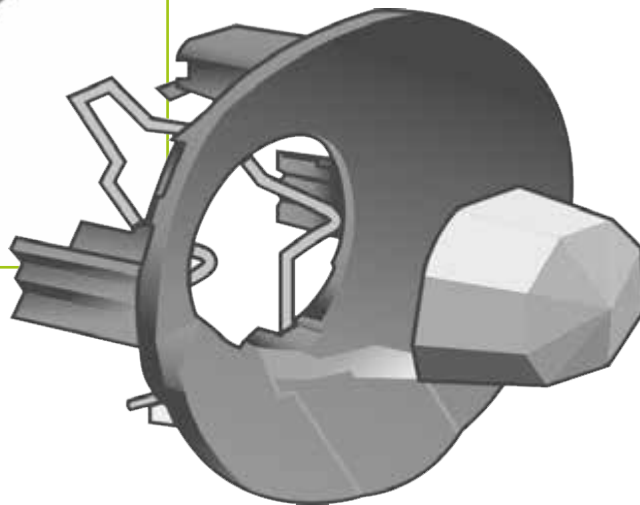

## 13.5. Elliptical-type optics

In a similar way to reflector lamps, elliptical lamps are designed depending on the lighting system used. Any type of light source can be used from Halogen to Xenon and LEDs.

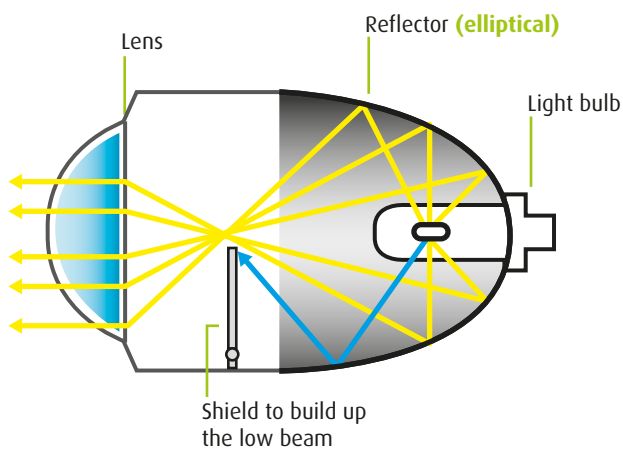

### The Elliptic headlamp reflector

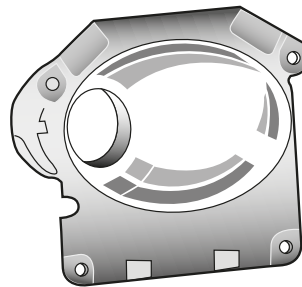

Compared to reflector-type designs, elliptic projectors give better performance and are significantly smaller in volume and frontal area. The light source is located in a reflector and the front lens focuses the beam.



# 13. High and low beams optical systems

## 13.5.1. The reflector: a key component to elliptic headlamps!

The reflector is not a basic ellipse. It is designed with several complex elliptical surfaces around the light source and parabolic surfaces on the edges.

- The reflection of the rays in the elliptic zones gives the preferred range and coverage (length & max intensity).
- The parabolic zones are designed to produce the light in close range (width & near light).

### The elliptical reflector is key to beam patterns

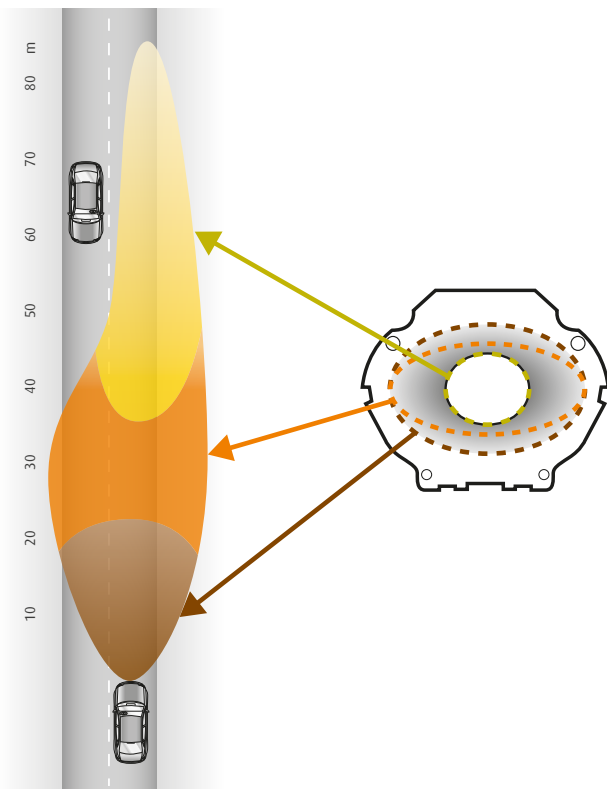

The mirror effect of the reflector and its corrosion treatment are paramount to ensure longevity of the projector. If the quality of the reflector is poor, the luminous flux and light projection homogeneity will be seriously affected.



### The lens

The lens is an optical device which transmits and refracts light, converging or diverging the beam.

The type of lens surface influences the cut-off projection on the road. The most used types of lenses are modulated and micro-structured ones.

The lens material used was historically glass. This was due to temperature issues by using Halogen or Xenon sources close to the lens. The growing popularity of LED light sources is changing this and new generations are now using plastic lenses. They offer design flexibility, weight improvements and more reactive bending mechanisms.



### The cut-off in elliptical-type optics

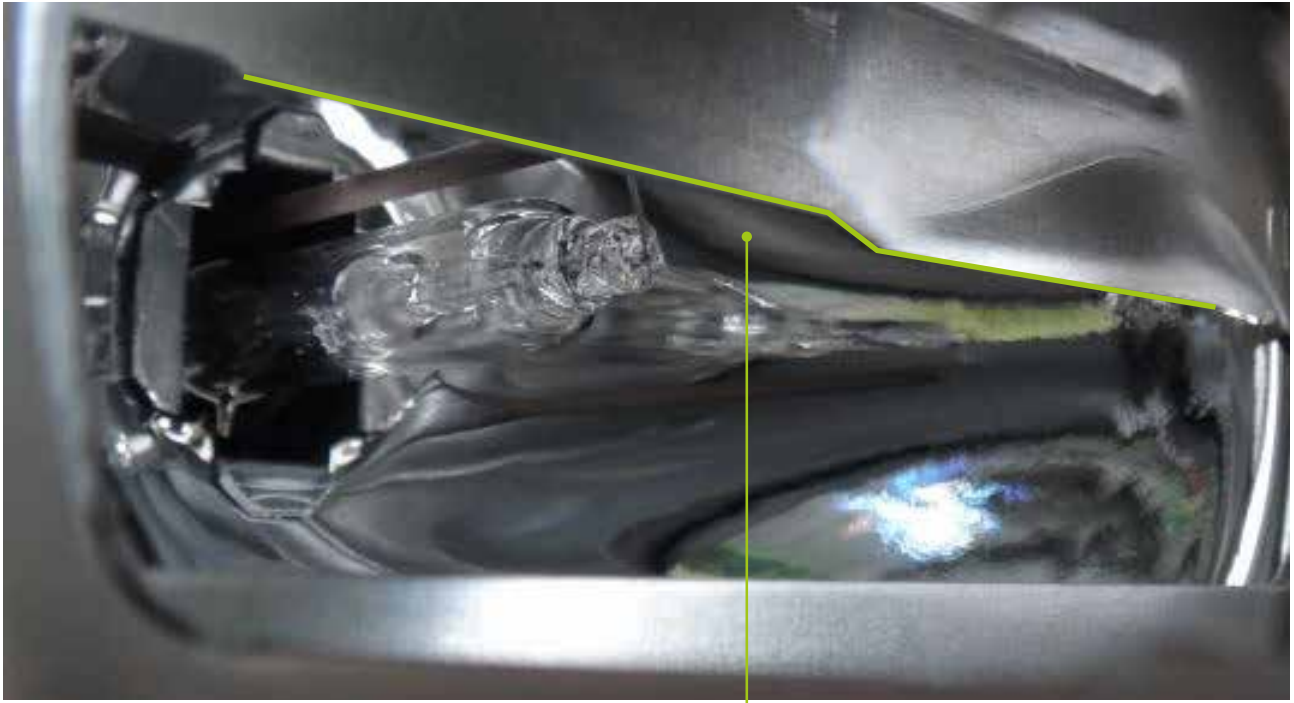

### 13.5.2. The cut-off in elliptical-type optics

Fixed shield for the cut-off

In elliptical-type optics, the low beam cut-off is created by a shield. This shield is located between the reflector and the lens; it can be fixed or mobile.

### 13.5.3. A vast product diversity

Headlamp systems combine elliptic and reflector lamps with different uses of light sources (H1, H7, Xenon). They allow a vast product diversity, ranging from full Halogen reflector-type products to fully Xenon elliptic-type. Modern headlight designs are now including LED lighting.

Part / For	Icon	Icon	Icon	Icon	Icon	Icon	Icon
AUDI (...)							
A4 (99>2001)							
01/1999→09/2001							
	↙	✕	✕	E	HCHR	H7+H7	CTL
						Xenon	087500 087501
						8D0941029AK	8D0941030AK
	↙	✕	✕	VEH	DCHR	D2S+H7	CTL
						Xenon	087496 087497
						8D0941029AN	



Elliptical module

Complex surface technology

Headlamp for Audi - A4 with D2S+H7 lamps and elliptical module + complex surface technologies

<b>087500</b>	<b>087501</b>
8D0941029AK	8D0941030AK
<b>087496</b>	<b>087497</b>
8D0941029AN	

# 13. High and low beams optical systems

## 13.6. Xenon Bi-function technology

Xenon Bi-function systems can produce both low and high beams with a single Xenon lamp. This makes road illuminance rendering (colour) a key advantage of this technology.

**Xenon Bi-function can be designed with both reflector-type and elliptical-type lamps.**

### 13.6.1. Xenon Bi-function with elliptic projector

In Xenon Bi-function elliptic projectors, the shield is not fixed. It becomes a shutter that switches over from low to high beam and vice versa.

#### Low beam in Xenon Bi-function elliptical module

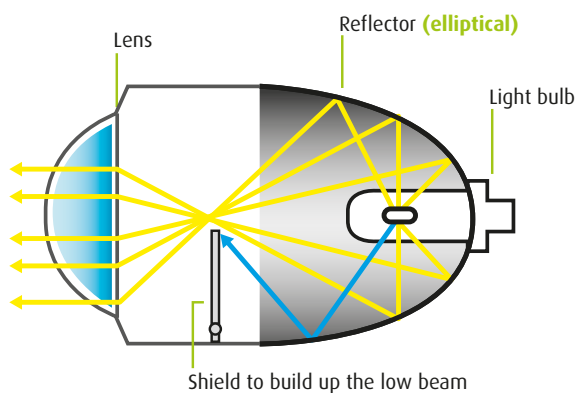

**Elliptic reflectors can build high and low beams with a unique lamp.**

The shutter has two functions:

- Creates the cut-off in low beam by masking part of the lamp luminous flux.
- Releases the cut-off mask to switch to high beam.

The actuation is performed either by a solenoid actuator or by an electro-mechanical system.

#### Xenon Bi-function shutter mechanism

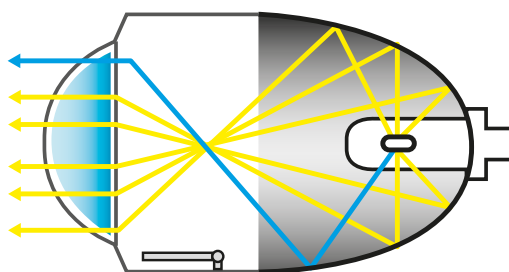
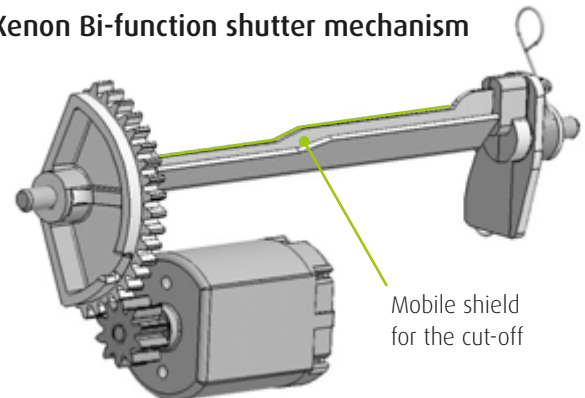

 <b>FORD</b> <b>C-Max (2010&gt;)</b> 08/2010 → 	
	VEH   DC/R   D3S   CTL     044439 044440 1744430 1744429

Headlamp for Ford - C-Max with D3S lamp and Xenon Bi-function elliptical technology

**044439 044440**  
1744430 1744429

### 13.6.2. Xenon Bi-function with complex-surface reflectors

In complex surface Bi-function systems, the switch over from low to high beam is performed by moving the complete reflector.

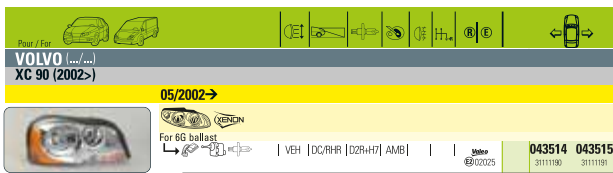

Headlamp for Volvo - XC 90 with D2R+H7 lamps and Bi-Xenon with complex surfaces technology

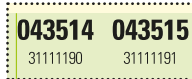

The reflector has two set positions inside the headlamp, one for the low beam and one for the high beam.

This feature is based on Valeo's third generation of complex-surfaces.

#### Bi-function with complex-surface reflectors

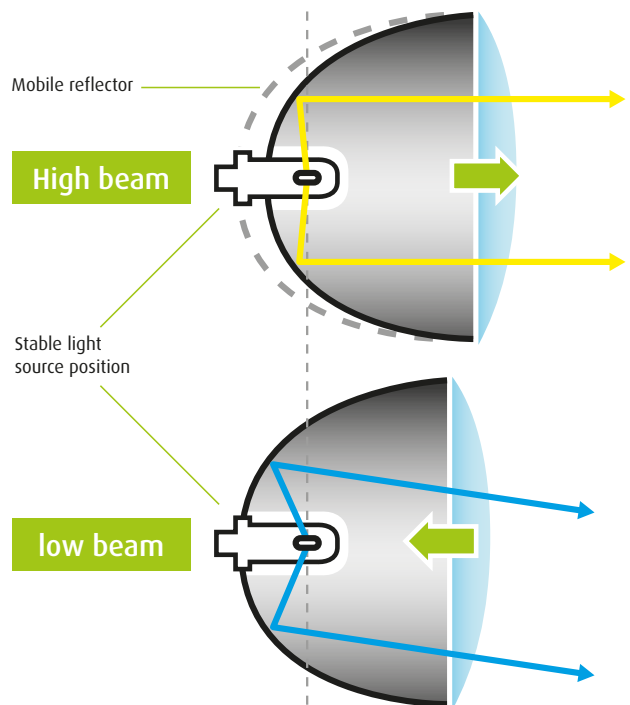

# 14

## From Xenon to LED

### 14.1. What is LED technology about?

LEDs or Light Emitting Diodes belong in the semiconductor diode family. Diodes are electronic devices that allow electrical current to flow in only one direction.

Diodes are built by bringing two slightly different materials together to form a P/N junction (Positive/Negative). **LEDs are different to power commutation diodes used in automotive alternators. The materials that are used in LEDs are not silicon-based semiconductors but materials that allow light emission.**

The material used in the LED governs the colour of the light that is emitted.

- InGaN material (Indium Gallium Nitride) is used for violet, blue, and green LEDs.
- InGaAlP material (Indium Gallium Aluminum Phosphide) is used for green, yellow, orange, and red LEDs.

Slight changes in the composition of these primary allows to change the colour of the emitted light.

In a P/N junction, the N side contains negative charge carriers, that are called "electrons", and the P side contains positive charge carriers, that are called "holes", which indicate the absence of electrons.

When a forward voltage is applied to the P/N junction, electrons move from the N side towards the P side and holes move from the P side towards the N side.

#### LED chip structure

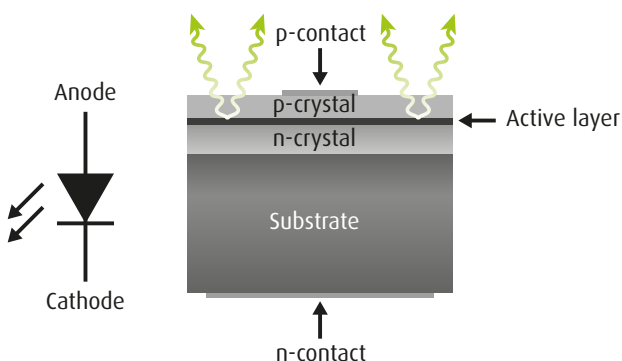

Electrons and holes combine in the border zone between the P and N regions (called depletion zone) and release energy called photons. This is the basis of light emission in LEDs.

- Photons released from the LED generate light.
- Photons not released from the LED generate heat.

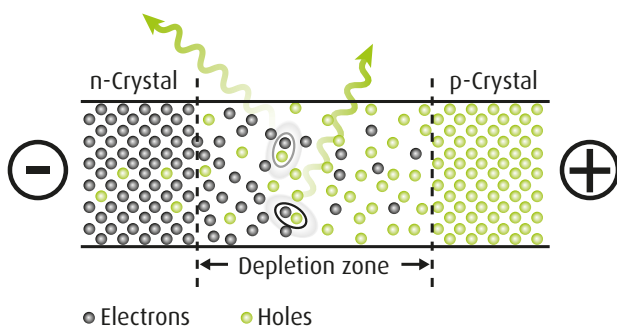

LEDs internal recombinations

The ratio between released photons to absorbed photons in the LED structure determines the light source efficiency.

LEDs light and heat extraction

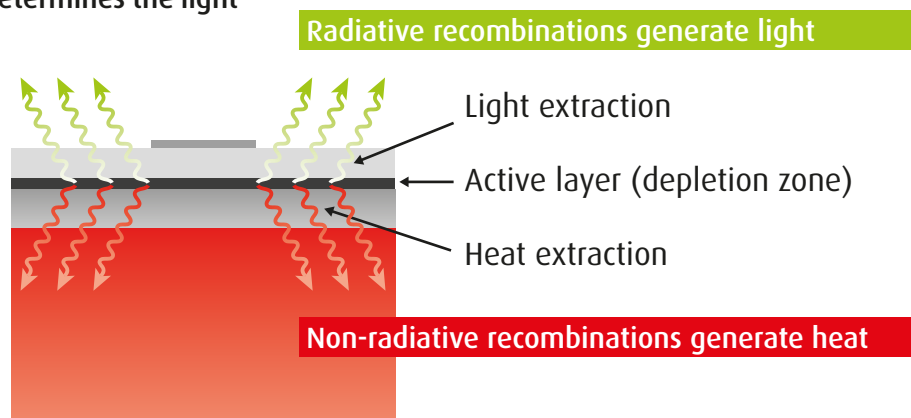

The LED chip is assembled into a package for mechanical protection, optical light diffusion, electrical connection, and thermal interface to dissipate heat.

**To improve the overall efficiency of LED packages it is important to optimize both light output and heat extractions.**

Light Emitting Diode technology has dramatically improved in the past decade. Until recent times the use of LED in automotive lighting was limited to rear signalling purposes due to limited light output and heat dissipation issues.

## 14. From Xenon to LED

### 14.2. A bright future for LED technology in car applications

LED power modules are now ready for vehicles. **2012 was the turning point for the implementation of LEDs in headlights for high and low beams.**

Valeo have developed a LED technology portfolio covering everything from entry level range to the most demanding AFS applications.

LED technology is already competitive with HID for cost and performances, and is presenting so many interests compared to Halogen with a cost becoming very reasonable, we can forecast a quick replacement of HID in the next coming years, and a more progressive replacement of Halogen in the next 10 years.

Valeo offers three levels of LED Front Lighting Systems

**PeopLED™:** LED low beam alternative to Halogen

**FullLED™:** LED solutions alternative to Xenon

**BeamAtic® Premium LED:** LED Glare-Free High Beam

### LED solutions for every car segment



### 14.3. Application for Ford Mondeo *Fullled™*

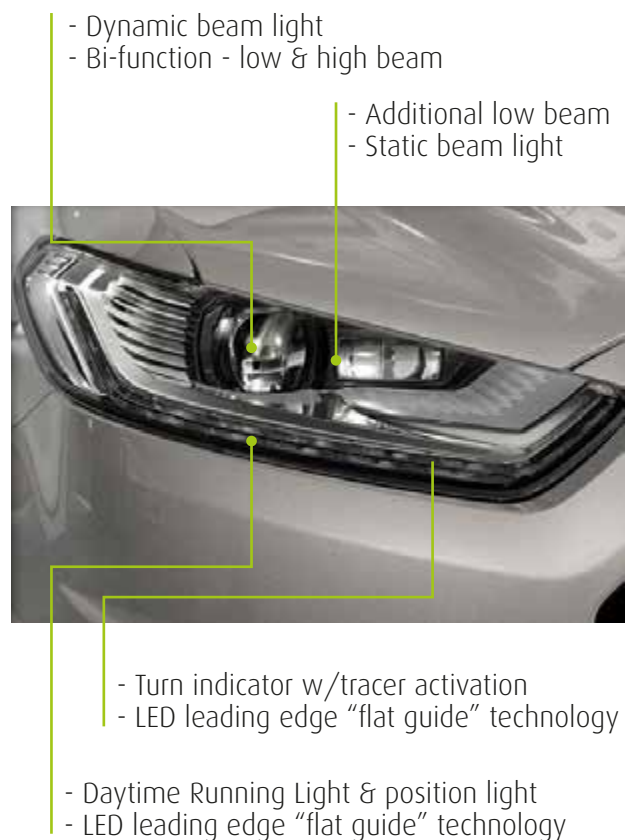

Ford Mondeo 2013 headlamp is built upon Valeo's BiLED™ technology; it is the first bi-functional FULLLED™ system providing low beam and high beam functions in a single compact design. It also offers optional dynamic bending capabilities.

This low-profile design (< 100 mm) is particularly innovative in that it switches from low beam to high beam illumination without any mechanical movement. To do so, a milled aluminum "folder" with a cutting-edge profile has been developed to ensure the perfect melding of both functions.

Two multichip-LEDs contribute to the low beam, while an additional third one is activated for the high beam.

## 14.4. Application for Seat Leon

In addition, this design takes advantage of the low heat emission of LEDs, allowing the BiLED™ module to be equipped with a plastic lens. This solution is much lighter than its equivalent glass-made lens and can be laser-welded to the module.



**Peopled™**

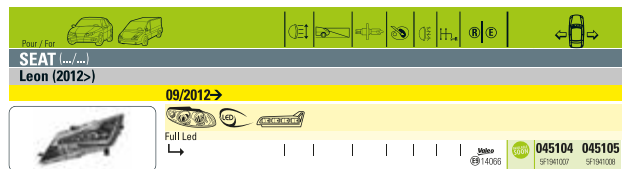

Headlamp for Seat - Leon with LED technology

**045104** **045105**  
5F1941007 5F1941008

Specifications:

- Static or Dynamic Bending Light (DBL).
- Stand alone integration or with complementary modules for LB and/or HB.
- Styling flexibility: lens shape.
- Photometric performances in 2012:
  - Low beam: 650 lm / 55 lx
  - High beam: 900 lm / 90 lx
- Power consumption:
  - Low beam: 20 W
  - High beam: 30 W



# 14. From Xenon to LED

## 14.5. What are the benefits of LED technology?

- **Start-up time and hot re-strike**

Compared to Xenon lamps, LEDs exhibit their full light power output upon activation, they do not require any warm-up time. In addition to this, LEDs can be switched ON and OFF without facing any hot re-strike issues (Xenon lamps need to cool down prior to being reactivated).

- **White colours profile**

### White LED phosphor structure

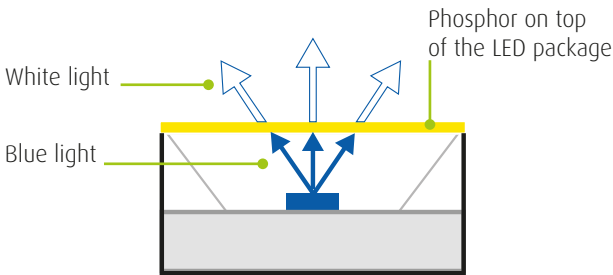

The most widely used approach to create a white LED is to use a blue LED chip combined with phosphor. A phosphor layer absorbs a portion of the blue light and converts it to a broad-spectrum white light.

By changing the phosphor content it is possible to achieve different white colour temperatures but this has an impact on the light output level.

**White LED technology is able to cover a wide range from 4500 K to 6500 K temperature.**

### CIE 1931 x,y chromaticity diagram

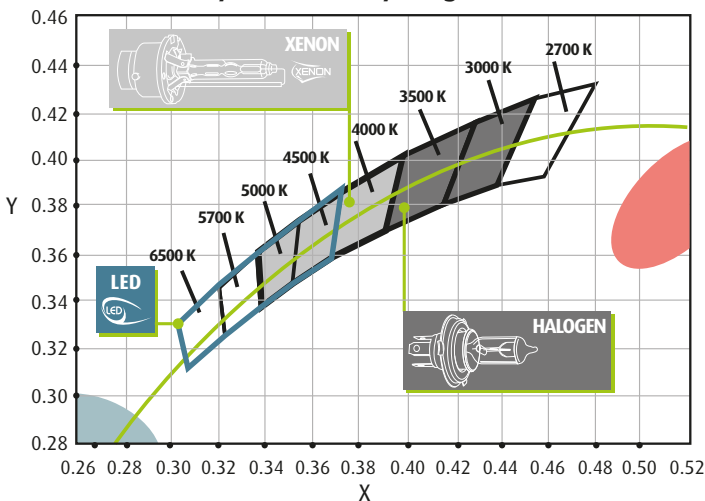

- **Flexible beam**

LED multi-chip architectures allow a light source matrix to be built that can produce the most appropriate illumination according to the driving conditions without any mechanical device.

LED matrix systems are the next step for future Advanced Front Lighting Systems.

- **Flexible light output**

One particular point of LED light sources is that they are quite easy to dim. This opens many new possibilities to signalling and lighting functions.

- **Styling effects**

Due to their compactness, LED light sources allow light unit designs to be more flexible. This advantage was initially used for signalling and Daytime Running Lamps (DRL) and was the perfect example of LED use for eye-catching signalling and brand image effects.

LEDs are now used for the entire lighting system on cars, trucks and buses applications.

- **Heat emission**

In comparison to Halogen or Xenon sources, LEDs facial heat radiation is low, allowing optic modules to be built with plastic lenses.

However, LEDs and particularly power LED modules are not cold sources. They generate heat that must be expelled from the chip base; this point is one of the most important points that are considered during automotive lighting design.

### LED module

#### OSLON Black Flat - KW H2L531.TE 800 lm @ 6.5 V - 1 A = 123 lm/W

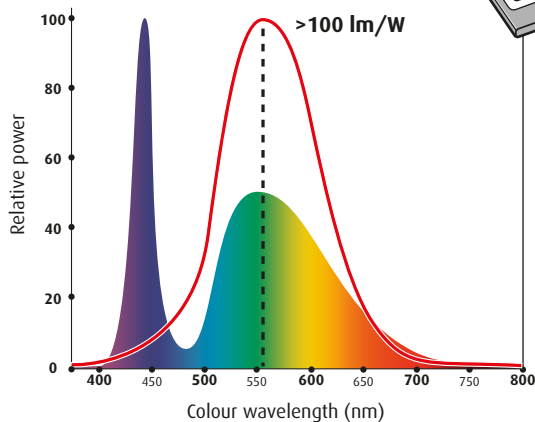

# 15

## AFS - Adaptive Front Lighting Systems

AFS is initially the name of the European Eureka project that was started in 1993. Its main target was to improve regulations as the front lighting systems evolve.

**Since 2003, legislation has evolved to include Adaptive Front light Systems (AFS), and is starting to include additional features to improve visibility and safety.**

The aim of AFS is to adapt light distribution on to the road to give optimum lighting performance in a range of driving situations.

The lighting systems have evolved from traditional light sources in headlamps to more complex designs using lighting modules that create several illumination profiles.

### 15.1. Bending lights

The very first generation of AFS focussed on bending lights.

- Fixed Bending Light (FBL) and cornering light.
- Dynamic Bending Light (DBL).

#### 15.1.1. Fixed Bending Light

One of the most important features of a headlamp with adaptive light distribution is the improved side illumination for driving situations in towns, at intersections and in small radius curves.

Fixed or static Bending Light consists of an additional complex reflective surface or elliptical module in the headlamp that is operated when turning. The function is activated according to the steering wheel angle.

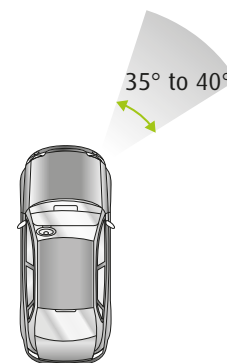

The first FBL in the world was equipped by Valeo on the Porsche Cayenne with an additional elliptical module inside the headlamp.

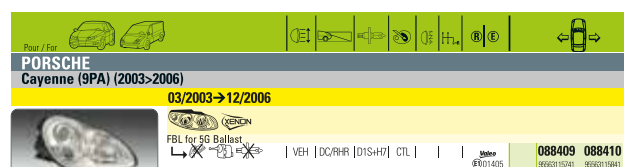

*Headlamp for Porsche - Cayenne with FBL technology*

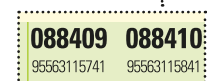

# 15. AFS - Adaptive Front Lighting Systems

## 15.1.2. Cornering

The cornering beam is dedicated to corner / bend visibility, it covers a wider angle than the Fixed Bending Light.

The function is switched on when:

- The driver activates the turn indicator
- Or the driver turns the steering wheel
- Car speed is under 40 km/h

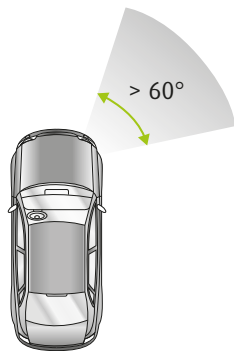

To implement a cornering function, Valeo applies this technology in two different ways:

- Inside the headlamp.
- Inside the foglamp.

		<b>03/2008 → 10/2010</b>	<b>043693 043694</b> <small>6208P9 6206P9</small>
--	--	--------------------------	--

Headlamp for Citroën - C5 with cornering technology in the headlamp

		<b>08/2006 → 09/2010</b>	<b>043682 043683</b> <small>63177184317 63177184318</small>
--	--	--------------------------	--

Foglamp for BMW - X3 with cornering technology in the foglamp

## 15.1.3. Dynamic Bending Light

The Dynamic Bending Light (DBL) function is operated by using a lighting module that can direct the beam pattern within an angular range according to the steering wheel angle.

The module rotates from left to right in the horizontal axis of the car, but the aiming of the beam (vertical axis of the car) is not part of the DBL feature.

The DBL is often fitted in conjunction with Xenon or LED lamps. However, one Halogen DBL product is supplied by Valeo for the Opel / Vauxhall Corsa D headlamp.

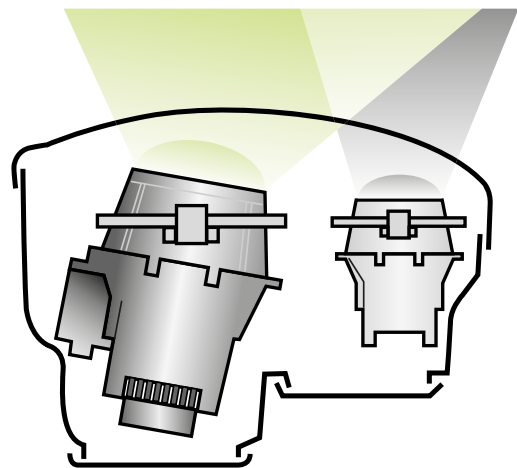

		<b>01/2011 →</b>	<b>044589 044590</b> <small>1226129 1226128</small>
--	--	------------------	--

Headlamp for Opel / Vauxhall - Corsa D with DBL technology and Halogen H9B lamp

<b>044589 044590</b> <small>1226129 1226128</small>
--

### With conventional headlamp

High headlamp aimed at -1,5%

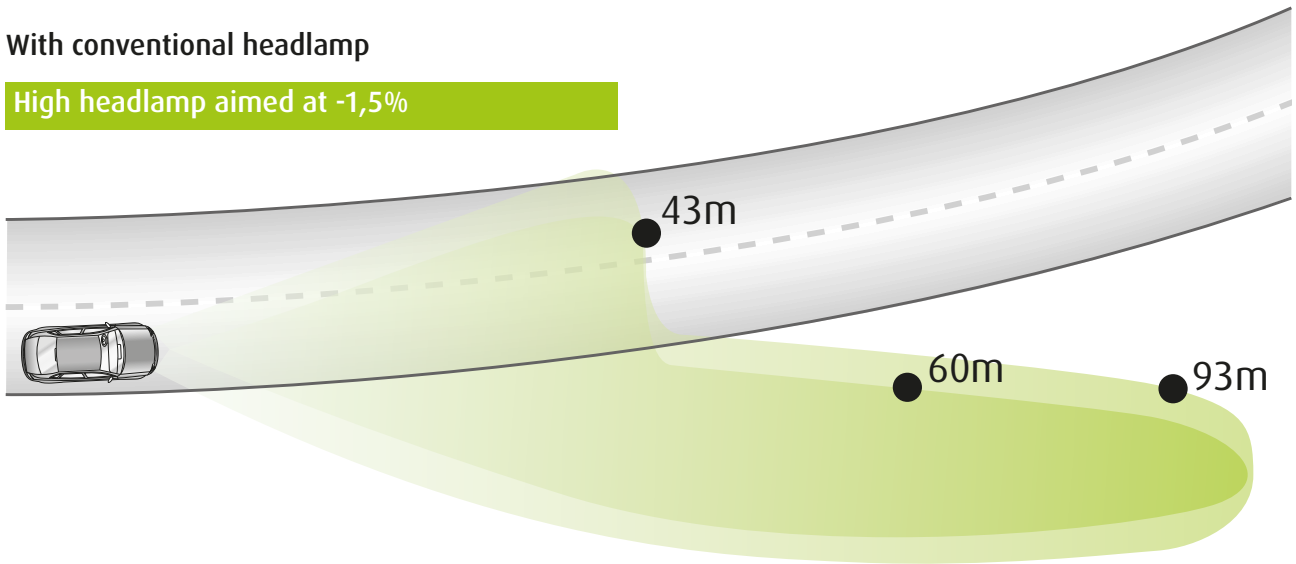

In normal condition, it is considered that the visibility distance is 50 m.

### With DBL headlamp

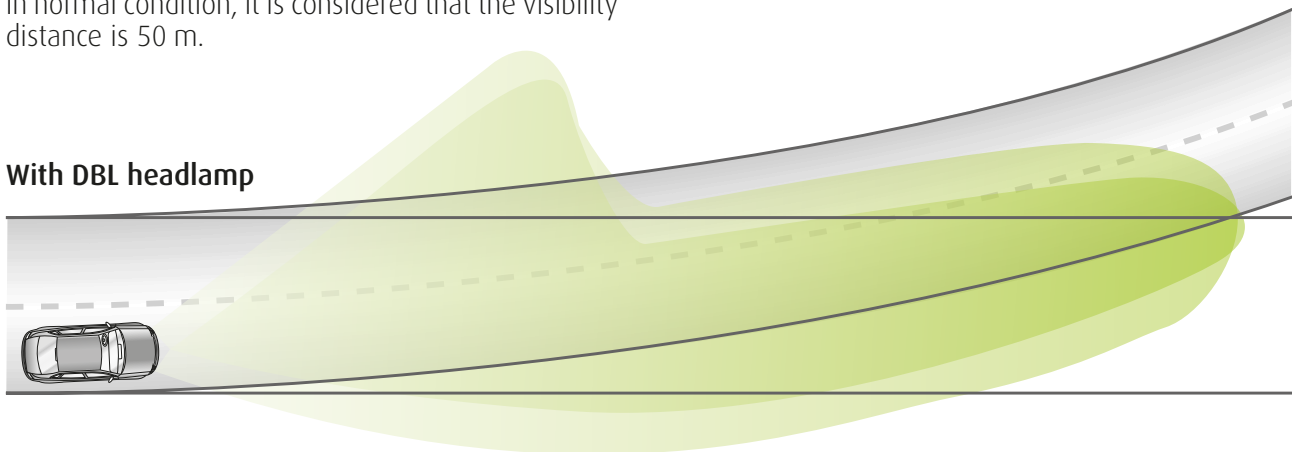

+44% visibility in curves thanks to Dynamic Bending Light!

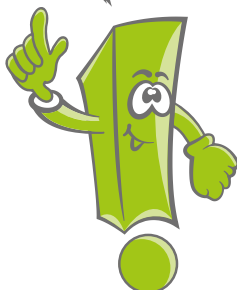

# 15. AFS - Adaptive Front Lighting Systems

## 15.2. Full Adaptive Front Lighting “Full AFS”

A lot of the improvements in vehicles are based on driving comfort and safety, there have been major developments in this field, such as ABS braking systems, stability controls, air bags, etc. Over the last decade there have been as well significant improvements in lighting systems to improve visibility and braking distances.

Traditional low beams using Halogen or Gas Discharge (HID) light sources do not provide sufficient illumination to allow a safe braking distance. For example, the emergency braking distance of a vehicle driving at 100 km/h (60 mph) including the human reaction time is at least 50-60 meters.

A standard low beam system with **a cut-off inclination of 1% can provide illumination up to a distance of about 25-30 meters.**

A new standard was set in 2004 to cope with this need, it defined the concept of “Long-Distance Illumination without Glaring (Dazzling) Effects”.

**The aim of long-distance illumination is a new type of low beam which enables continuous illumination for a safe braking distance of approximately 60-70 meters.**

**An adaptive “cut-off line”** provides illumination for a safe braking distance, without causing any dazzling effect on other road users, and enables safe and comfortable night driving.

Since 2006 the AFS has improved a lot providing more features.

Full AFS technology allows drivers to benefit from optimum visibility under all conditions, reducing the stress of driving at night and improves visual comfort and safety.

The system automatically adapts light distribution according to the position of the preceding and oncoming traffic.

**Full AFS introduces a new era of light distribution for several typical driving situations and adapts the beam according to:**

- **Road type.**
- **Road conditions.**
- **Weather conditions.**
- **Drivers actions (side indicator/steering wheel).**

## Full AFS classes of light distributions

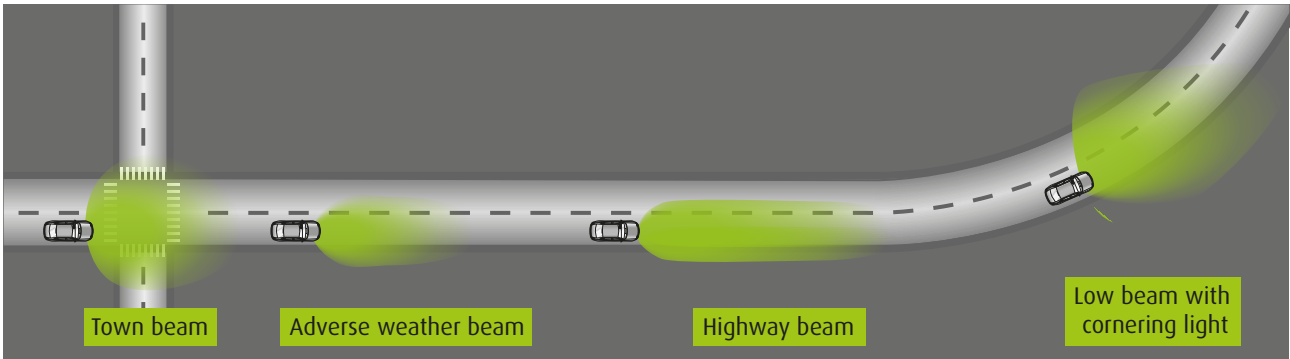

### 15.2.1. Full AFS for the Audi Q7

Always at the forefront of technology, Valeo is supplying Audi with the range-topping 2009 version of the Q7, AFS Tri-Xenon headlights that combine high beam, low beam and highway functions with LED based DRL (Daytime Running Lamps).

The entire range of Audi Q7 headlights (Halogen, dual-function Xenon and AFS Tri-Xenon) is available in the aftermarket.

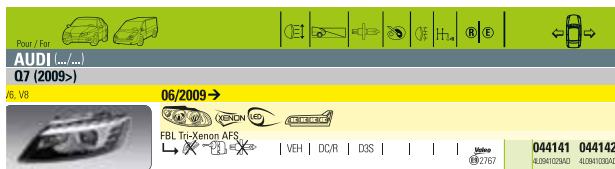

Headlamp for AUDI - Q7  
with Tri-Xenon AFS technology

**044141 044142**  
4L0941029AD 4L0941030AD

### Valeo's full AFS for the 2009 Audi Q7



# 15. AFS - Adaptive Front Lighting Systems

## 15.2.2. Automatic operation of the AFS

The first generation of adaptive systems permitted to improve visibility by directing illumination on the road, complementary to this the AFS system is able to vary the beam cut-off in small increments by using electrical actuator motors.

Lighting modules are able to create dedicated illumination profiles (classes) by combining several features such as:

- Right beam motion - horizontal and vertical
- Left beam motion - horizontal and vertical
- Aiming control
- Cut-off diversity

Valeo's "Full AFS" solution is based on a Tri-function module providing 3 light beams:

- Low beam
- High beam
- Motorway beam

### Xenon lighting module

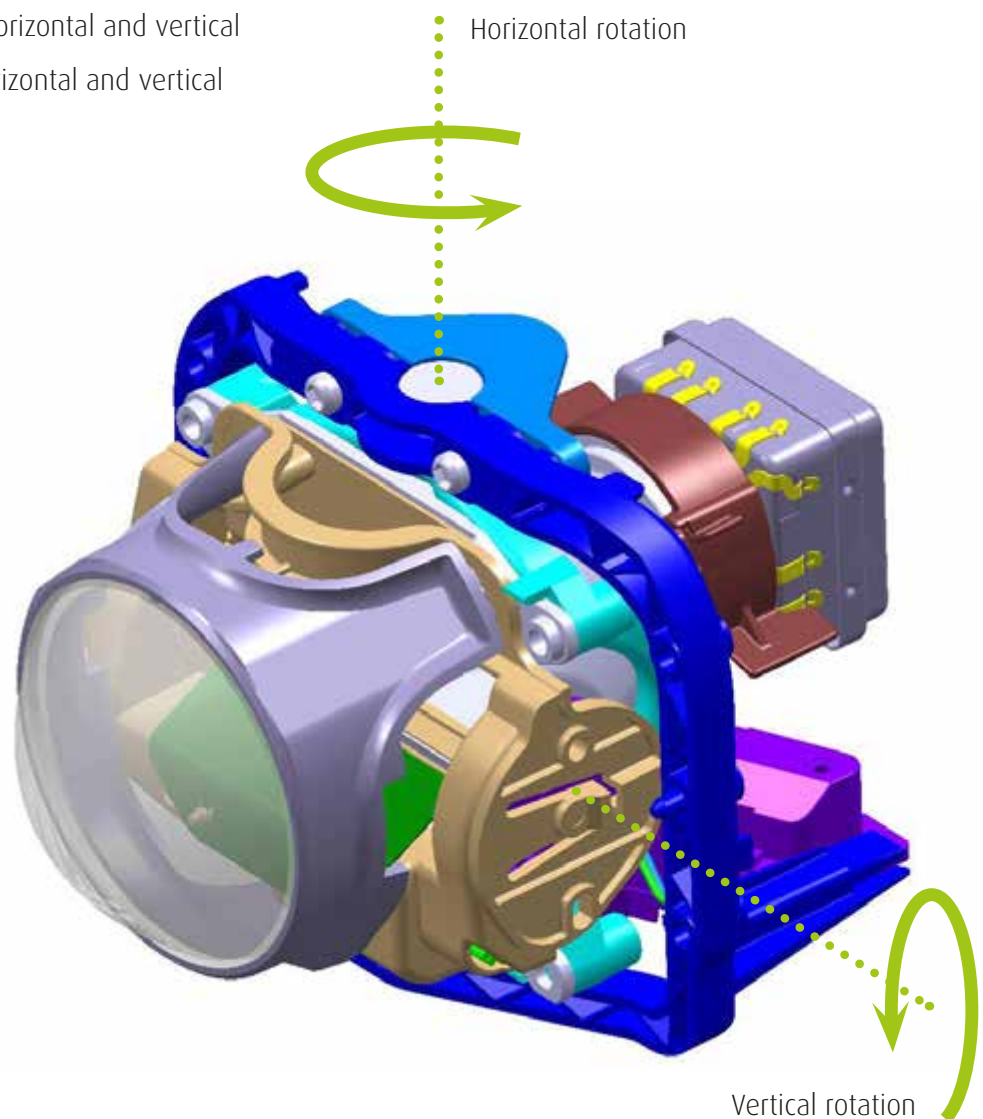



By mixing a combination of 3 main beams and automatic levelling positions the system is allowed to create 3 additional functions:

- Town lighting
- Adverse weather beam (wet road)
- Tourist beam (beam adaptation to avoid glare when driving abroad)



#### Full AFs - Tri-function mechanism

AFS are regulated and detailed in European regulations ECE R48 and ECE R123. The projector beam steps are basically categorized in passing beam classes and modes:

- "Classic" class C modes
- "Town" class V modes
- "Motorway" class E modes
- "Wet road" class W modes
- "Bending modes" T modes

### 15.2.3. AFS - Classes and Modes

The term "**class**" defines main beam patterns (C/V/E/W/T). The term, "**mode**" defines conditions or events when driving requires the lighting system to adapt to a class or to switch from one class to another by adapting the beam profile.

AFS systems continuously adapt the illumination on the road according to the ongoing mode.

The system is designed to be adaptive by using control signals guided by sensors which are capable of detecting and reacting to each of the following inputs:

- Ambient lighting conditions.
- The light emitted by the front lighting and front signalling systems of oncoming vehicles.
- The light emitted by the rear lighting of preceding vehicles; additional sensors may be used to improve the system's performance.

The changes within and between classes and their modes of AFS lighting functions are performed automatically without causing discomfort, distraction or glare, neither for the driver or for other road users.

A dedicated photometric chart has been issued for AFS. It is based on the Xenon lighting systems initial chart with all provisions of new classes and their specific modes.



# 15. AFS - Adaptive Front Lighting Systems

## 15.2.3.1. Classic beam

This beam is the low beam; it is the default pattern of the AFS system.

“classic” class C modes – beam on the road



The “classic” class C mode(s) of the low beam shall be activated if no mode of another low beam class is activated; it is also called “Neutral state”.

“classic” class C modes – H/V aiming

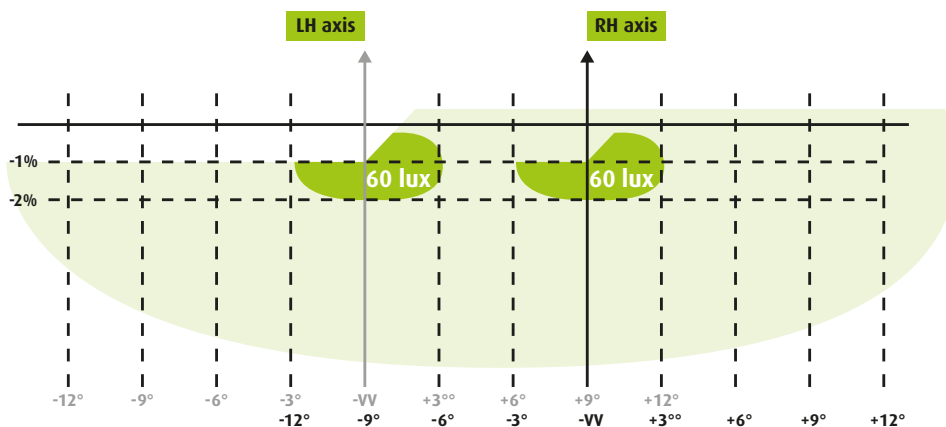

### 15.2.3.2. Town beam

The town beam offers a wider beam pattern for sidewalks visibility with increased foreground and reduced hot spot (less glaring effect).

### “Classic” class C modes – beam on the road



The “town” class V mode(s) of the passing beam shall not operate unless one or more of the following conditions is/are automatically detected:

- Roads in built-up areas.
- Vehicle’s speed not exceeding 50 km/h.
- Roads equipped with a fixed road illumination.
- A road surface luminance of 1 cd/m<sup>2</sup> and/or a horizontal road illumination of 10 lux being exceeded continuously.

### “town” class V modes – H/V aiming

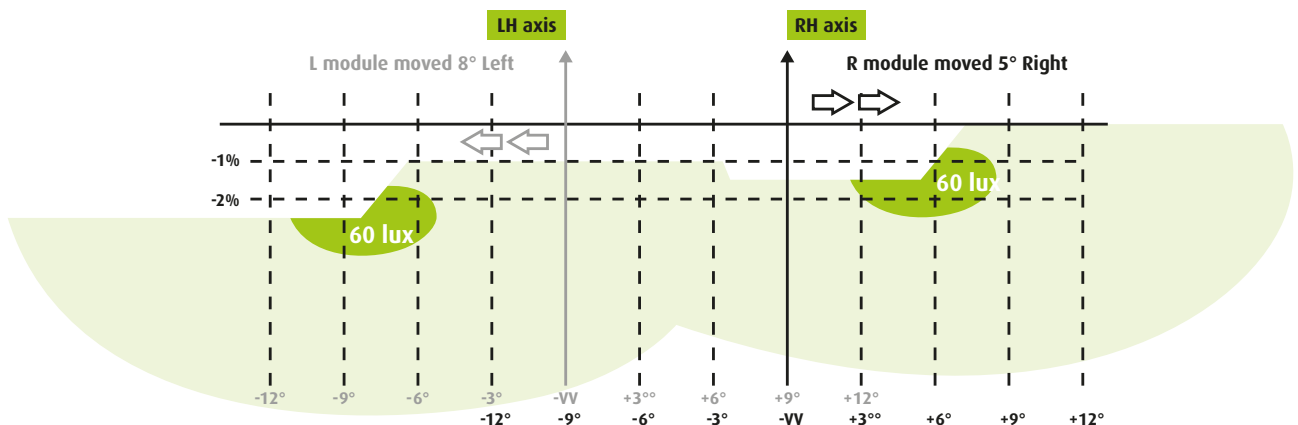

# 15. AFS - Adaptive Front Lighting Systems

## 15.2.3.3. Motorway beam

The motorway beam offers:

- An improved visibility distance, up to 120 m, without glaring other vehicles.
- A doubled intensity (120 lux) comparing to maximum possible intensity of the low beam.
- An increased light-range by 60 meters.

### “Motorway” class E modes – beam on the road



The class E mode of the passing beam (motorway light) has a higher luminous intensity and a raised cut-off offering increased forward visibility for the driver. To avoid glaring other road users it is only operated on roads where the traffic direction is separated by means of road construction, or, a sufficient lateral separation of opposing traffic is identified, a typical motorway condition.

New technology based on sensors such as camera systems and GPS navigation can provide accurate information to determine if motorway conditions are fulfilled regardless of vehicle speed.

- The “motorway” class E mode(s) of the passing beam shall not operate unless the vehicle’s speed exceeds 70 km/h and the road characteristics corresponding to motorway conditions are automatically detected.

In case of the following modes of class E, the cut-off aiming is adapted to the speed level.

- E1** The vehicle’s speed exceeds 100 km/h, the cut-off is set to 0.59% (0.34°) for a maximum illumination range.
- E2** The vehicle’s speed exceeds 90 km/h the cut-off is adjusted to 0.78% (0.45°) for a medium illumination range.
- E3** The vehicle’s speed exceeds 80 km/h the cut-off is pulled down to 1% (0.57°) to avoid glare of opposing and oncoming vehicles.



## “motorway” class E modes – H/V aiming

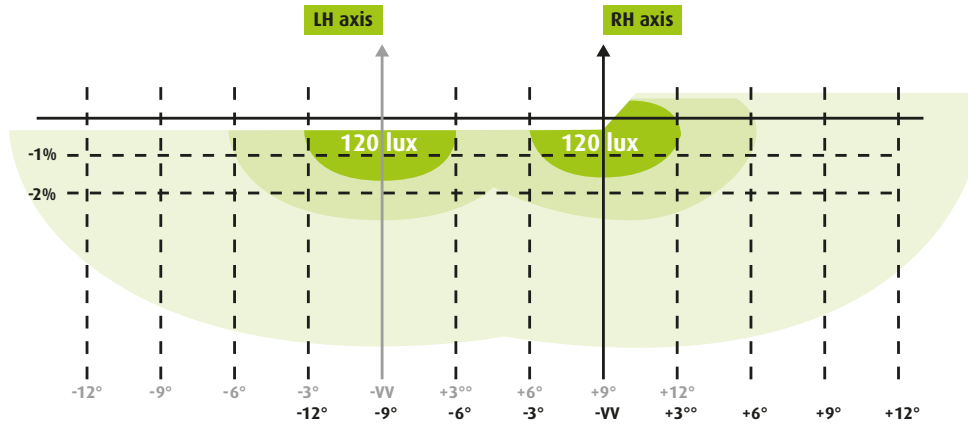

### 15.2.3.4. Wet-road beam

The wet road beam offers an improved hot spot for better “light penetration” and reduced foreground light to avoid “mirror effect” on wet roads.

## “wet road” class W modes – beam on the road



The “wet road” class W-mode(s) of the passing beam shall not operate unless the front fog lamps, if any, are switched OFF and one or more of the following conditions is/are automatically detected:

- The wetness of the road has been detected automatically.

- The windshield wiper is switched ON and its continuous or automatically controlled operation has occurred for a period of at least two minutes.

## “wet road” class W modes – H/V aiming

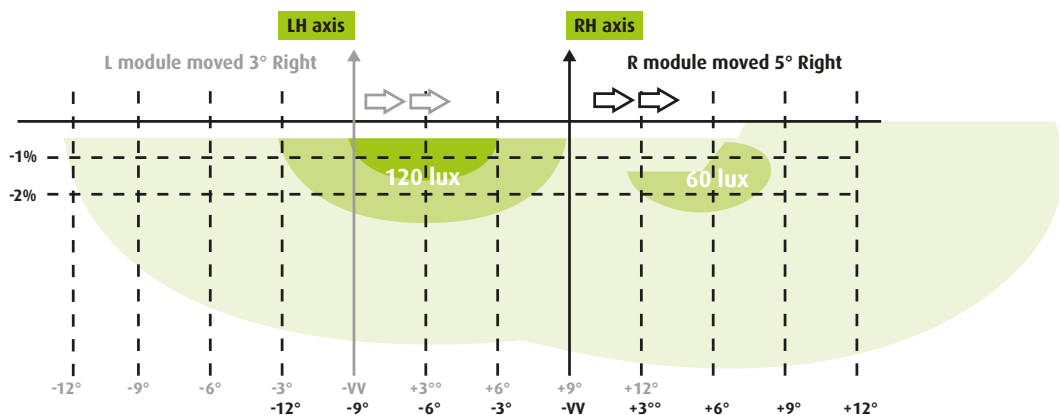

# 15. AFS - Adaptive Front Lighting Systems

## 15.2.4. Additional provision to the AFS systems

- **It shall always be possible for the driver to set the AFS to the neutral state and to return it to its automatic operation.**
- A mode of a class C, V, E, or W passing beam shall not be modified to become a bending mode so-called T unless at least one of the following characteristics (or equivalent indications) are evaluated:
  - The angle of lock of the steering.
  - The trajectory of the centre of gravity of the vehicle.
- A visual failure tell-tale for AFS is mandatory.
- If the main-beam is adaptive, a visual tell-tale shall be provided to indicate to the driver that the adaptation of the main beam is activated. This information shall remain displayed as long as the adaptation is activated.
- An AFS shall be permitted only in conjunction with the installation of headlamp cleaning device(s) if the total objective luminous flux of the light sources of these units exceeds 2000 lm per side, and which contribute to the class C (basic) passing beam.
- The adaptive main-beam shall be switched off when the illuminance produced by ambient lighting conditions exceeds 7000 lx.

# 16

## Glare-Free High Beam (GFHB)

The Glare-Free High Beam (GFHB) also known as Adaptive Driving Beam (ADB) is the next evolution of the Full Adaptive Front Lighting (AFS) system.

Definition according to ECE R48 rev.9:  
*“Adaptive main-beam” relates to a main-beam of the AFS that adapts its beam pattern to the presence of oncoming and preceding vehicles in order to improve the long-range visibility for the driver without causing discomfort, distraction or glare to other road users.*

### 16.1. Why the Glare-Free High Beam?

To make a new step up in road illumination performance, the lighting system had to overcome the following points:

- The high beam in its original definition glares oncoming traffic in many situations and cannot be used permanently in its current format.
- As a general rule, drivers have a reluctance to operate the main beam and are used to frequently switch back from high to low beam too early.
- The separation distance between vehicles implies that the low beam cannot provide an optimized forward illumination in most of the driving circumstances.

# 16. Glare-Free High Beam (GFHB)

## 16.2. Valeo BeamAtic® Premium System

Valeo's first ADB system is called BeamAtic® Premium, it was launched in its Xenon version in 2010 and is extendable to other light sources.

Valeo BeamAtic® Premium is about lighting automation for 80 m far obstacle visibility; it particularly solves the problem of road side visibility without glaring other road users.

The Glare-Free High Beam is fundamentally a high beam. However, it evaluates the road scene ahead by using cameras and image processing and automatically adapts the light distribution according to the position of the preceding and oncoming traffic.

ADB bloc diagram

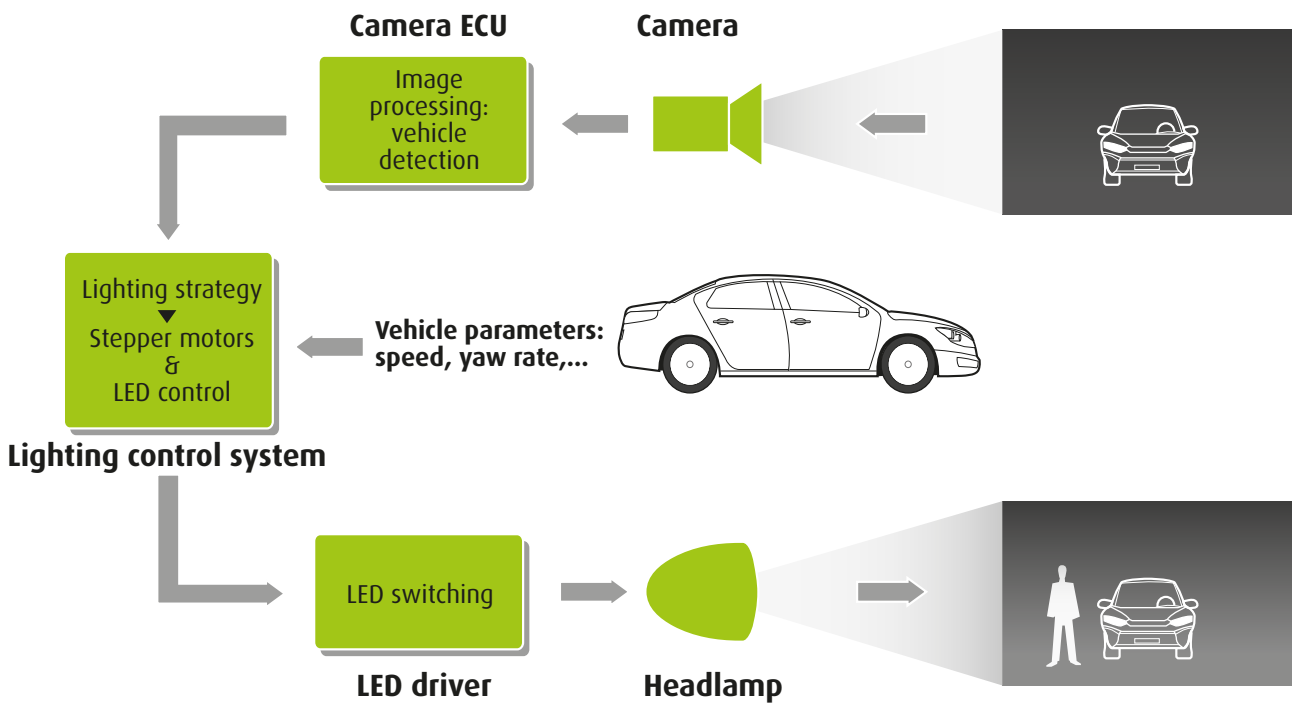

## Opposing traffic

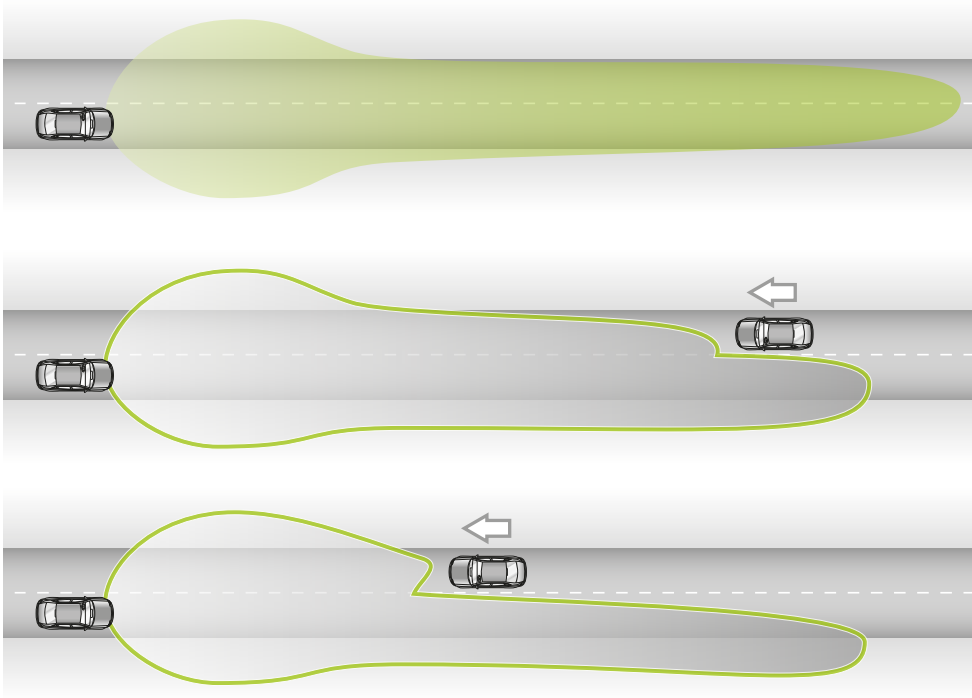

No opposing traffic  
full main beam operated

Main beam light  
distribution adapted to  
avoid glare to oncoming  
vehicle

## Adaptive driving beam in opposing traffic

When the image processor identifies a vehicle that is oncoming or driving ahead, a shield inside the headlight moves to mask a part of the beam. This shield then prevents light from entering the area where the other road user is and tracks their trajectory to continue to prevent dazzling.

This provides the driver with the ideal headlamp range at all times, enabling better and earlier recognition of dangers without irritating or jeopardizing other road users.

Valeo BeamAtic® Premium operates for both opposing and preceding traffic.





## Preceding traffic

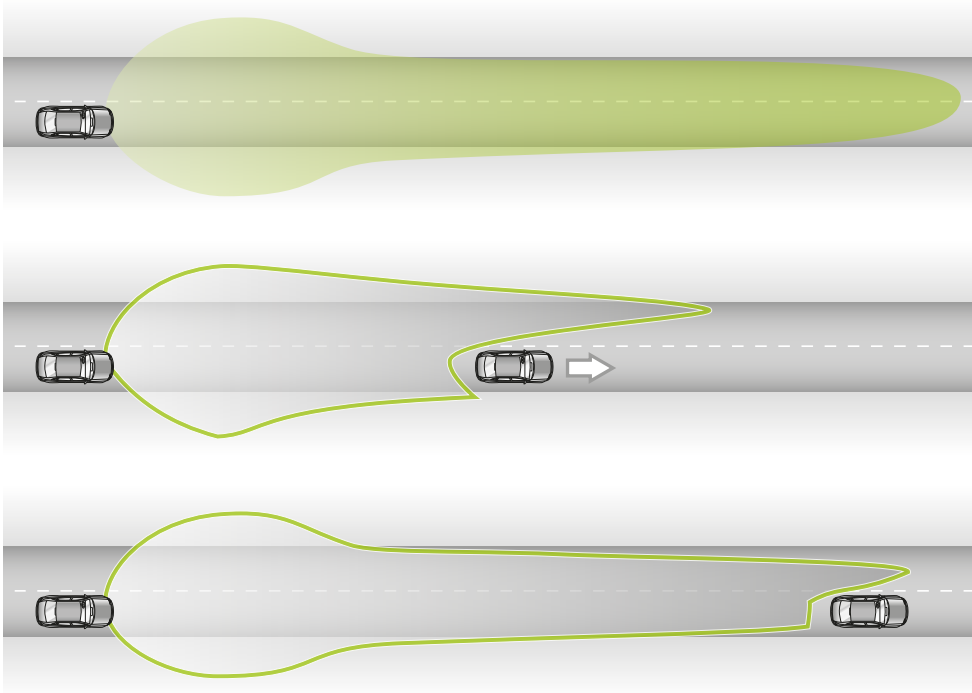

No preceding traffic  
full main beam operated

Main beam light  
distribution adapted to  
avoid glare to preceding  
vehicle

## Adaptive driving beam in preceding traffic



## 16.2.1. BeamAtic® Premium applications

Valeo Glare-Free High Beam systems have been available since 2010 on a number of Volkswagen models, including the Passat.

The latest generation is fitted on Volkswagen Golf VII.

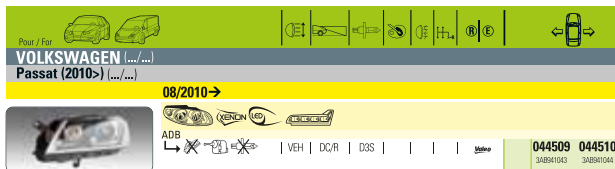

Headlamp for Volkswagen - Passat with ADB technology

**044509 044510**  
3AB941043 3AB941044

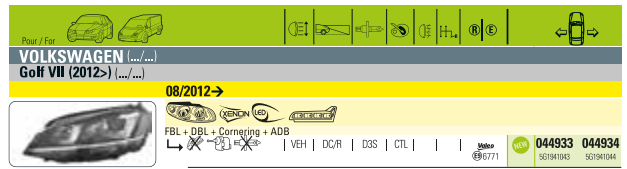

Headlamp for Volkswagen - Golf VII with ADB technology

**044933 044934**  
5G1941043 5G1941044

From the very first applications with Xenon light sources, Valeo's Glare-Free High beam systems have continuously improved for an optimum illumination of the road scene, but there are some important criteria that demand Glare-Free High Beam systems to be evolved further.

Headlamp for Volkswagen - Golf VII with ADB technology



## 16. Glare-Free High Beam (GFHB)

### 16.3. What makes a good Glare-Free High Beam system?

For the evaluation of the functional performance of a GFHB system, six different criteria may be identified:

#### 1. Illuminating pedestrians and hazards:

The illumination of pedestrians and hazards is a feature that distinguishes a GFHB system from traditional low beams.

#### 2. Beam stability below the cut-off:

One of the disadvantages of the Xenon GFHB systems on the market is that the complete beam is laterally displaced to track the trajectory of the other vehicle detected. The module's steering strategy naturally takes account of this fact by restricting the lateral displacement of the headlamps in GFHB mode, resulting in a system that is essentially active on relatively straight roads. A GFHB system with a fixed beam below the cut-off – which produces no glare – would be able to maintain a good illumination of the road ahead, regardless of any bends in the road.

#### 3. Beam stability above the cut-off:

The lateral movement of the beam above the cut-off could be considered undesirable because areas where they are best illuminated are not in the direction the vehicle is heading. A fixed beam above the cut-off would have an advantage of directing the light along the road regardless of the position of the detected vehicle.

#### 4. Light output:

Current systems generate the obscured area by framing the vehicle detected with two symmetrical beams whose lateral upper quarters are concealed. Therefore, on both sides, light is half as strong as a conventional high beam. A GFHB system with equivalent light to a high beam outside the obscured area would perform better.

#### 5. Continuous, precise tracking of vehicles detected:

The capacity of a GFHB system to precisely frame other vehicles is a significant factor in user comfort. The angular pitch of lateral displacement of the shadow should be fine enough to make tracking seem continuous.

#### 6. Obscuring several different areas:

Systems currently in production can only generate a single obscured area. If at least two vehicles are detected, the system must obscure an area that encompasses both. A system that could generate several separate obscured areas would be able to offer optimal lighting of the field, particularly in the space between the vehicles detected.

## 16.4. LED-Based Glare-Free system designs

LED technology is the latest evolution for Glare-Free High Beam projectors.

When compared to Halogen and Xenon, LEDs offer many benefits, including:

- Luminous efficacy (in lumens per watt).
- Lifespan that exceeds that of the vehicle itself.
- Flexibility in terms of optical design and style: several LEDs produce the beam, and each one can be coupled with particular optical systems.

LED systems can replace and even exceed Xenon headlamp performance. In order to illustrate the features of different LED systems, five different concepts are taken in a single scenario: the test car is approached by a vehicle on the left lane 80 m ahead, which is just out of the low beams' reach.

### Multibeam

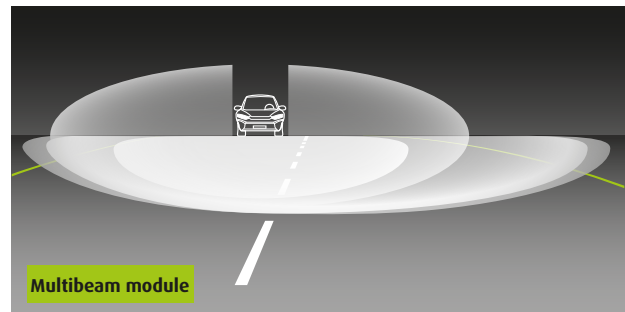

Depending on the position of a horizontally rotating internal shield with different cut-off forms, the lamp has alternatively low beam, motorway beam, high beam, GFHB (L-shaped) and a flat beam with a linear cut-off.

**One or more additional modules can be added to the main module to boost the quantity of light projected in low beam or high beam. (Ford applications: S-Max, Galaxy)**

In Glare-Free High Beam mode, the whole beam rotates around a vertical axis according to the position of detected vehicles. Similar to Xenon lights, Multi Beam is compact and offers a precise lateral positioning of the vertical cut-offs.

## 16. Glare-Free High Beam (GFHB)

### Sail beam

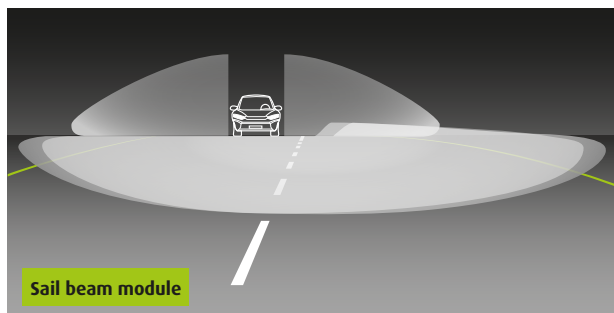

The main limitation of adaptive Xenon systems is that the entire beam has to rotate. If an oncoming vehicle is passed when driving round a right-hand bend, for example, the beams will be directed towards the left to frame the detected vehicle and prevent glare, which will reduce the quantity of light projected into the bend.

To offset this, the sail beam version, pairs the static cut-off beams with two symmetrical beams –each projected by one of the headlamps.

These sail-shaped beams are directed above the cut-off and project most of their light above the horizon. They have a vertical cut-off, are laterally mobile and positioned on either side of the vehicle detected. The brightest areas are located as close as possible to the beams' lower inside angle in order to surround the vehicle or vehicles detected closely with the strongest light possible. Given that the low beams are fixed, there are no restrictions on the travel of the sail beams other than the time taken to realign with the vehicle when switching back to high beams.

### Dynamic shadow

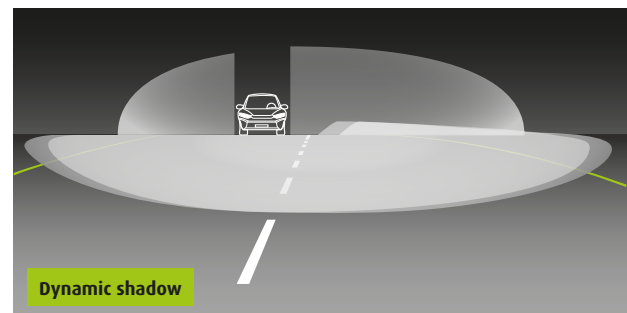

In the systems described before, the vertical cut-off shield has a fixed position inside the beam. It is then necessary to rotate the beam to align this cut-off with the vehicle detected.

The dynamic shadow module is equipped with a laterally mobile shield that can move the vertical cut-off without moving the beam, producing a beam that remains aligned with the vehicle while the obscured area can move as far as necessary.

When the shield is completely retracted, the beam is a high beam. For low beam this GFHB module is paired with a separate low beam module.

## Matrix beam

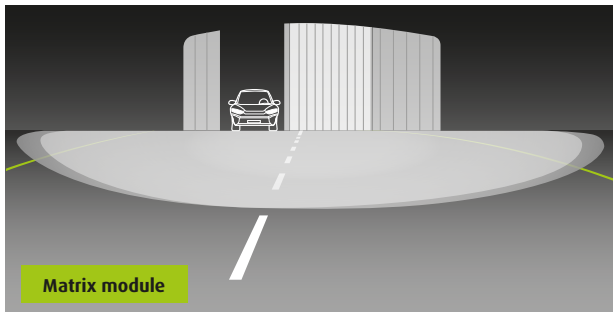

## Pixel lighting

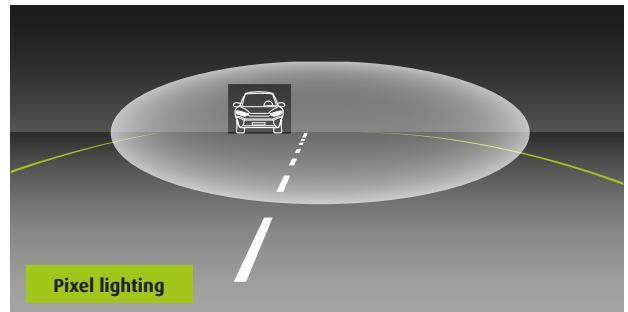

Despite their high efficiency all the systems described above still present some functional shortcomings. First of all, there is only one obscured patterns area. In the event that two or more vehicles are detected, it will encompass the entire group, eliminating visibility between the vehicles.

Secondly, the quantity of light projected above the cut-off, on either side of the obscured area, is no longer the sum of the right and left beams, as in conventional high beam, since the beam on the opposite side is obscured.

The Matrix Beam system dating back to Audi allocates a specific LED chip to every sector of the field for lighting or obscuring. The obscured area is obtained by extinguishing one or more LED chips, for each of the headlamps, without any moving part. This solution maintains maximum light output throughout the non-obscured area and can obscure several different areas on the condition that the space between two consecutive obscured areas exceeds the size of the elementary area.

Each of the lighted areas described in a Matrix Beam light can be considered as a macro pixel, produced by the combination of an elementary LED and a dedicated optic. The number of these macro pixels is therefore limited by the volume of the headlamp.

To improve resolution, the activation and extinction of the pixel must be dissociated from the activation and extinction of a LED element, like a video projector whose light source remains lit regardless of whether the pixels of the projected image appear or not.

A solution being considered by Valeo is to shape the beam through an LCD matrix. Contrary to Xenon light sources, the absence of infrared radiation in the light emitted by LEDs offers the possibility of increasing the source power opening up a number of possibilities.

These high-resolution systems will be as effective as a Matrix Beam system, but more precise, meeting all six functional criteria listed above.

### Glare Free High Beam evaluation criterias

▼ CRITERIA	TECHNOLOGY ▶	LOW BEAM	MULTI BEAM	SAIL BEAM	DYNAMIC SHADOW	MATRIX BEAM	PIXEL LIGHTING
▶ Illuminating pedestrians and hazards			✓	✓	✓	✓	✓
▶ Beam stability below the cut-off		✓		✓	✓	✓	✓
▶ Beam stability above the cut-off					✓	✓	✓
▶ Light output equivalent to high beam						✓	✓
▶ Precise tracking of the vehicle detected			✓	✓	✓		✓
▶ Obscuring several different areas						✓	✓

# 17

## What about lasers in automotive lighting?

Lasers are able to reach high levels of luminance due to their very concentrated beam.

The intrinsic laser characteristics make them good candidates for first application as high-intensity hot-spots and possibly for larger beams in future times.

Lasers are monochromatic light sources, so prior to be usable in headlamps a conversion must operate to obtain a white light. Similarly to white LEDs, current developments use a blue laser source that excites a yellow phosphor and emits a very bright white light.

Laser-based light sources use laser diode emitting in the near ultraviolet and blue range between 405 nm and 450 nm.

### 17.1. Laser white source benefit from LED experience

Whatever the light source, researchers always continue to improve: efficiency, colour stability and reliability.

White LEDs have now improved over the last few years and manufacturers are now benefitting from this experience for Laser-based light sources.

Management of heat dissipation and phosphor implementation in the LED package are known to be crucial to lifespan and colour stability.

Extreme temperatures cause LEDs chip and phosphor efficiencies to drop, leading to a shift in the peak emission wavelength and considerably reducing its life span.

#### Laser based projector scheme

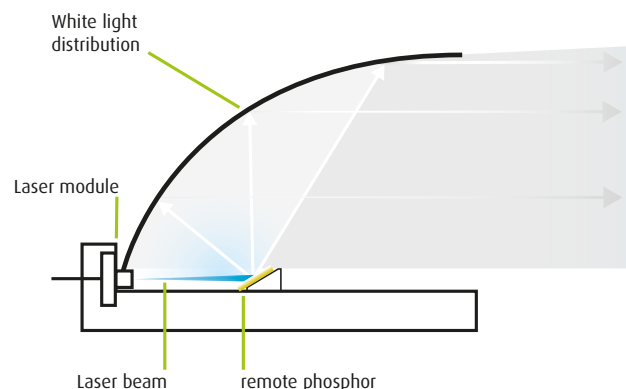

The blue laser light is converted to white light on the phosphor surface

To cope with this, most modern high power LEDs are built upon "remote phosphor architectures".

In these LEDs the phosphor is positioned away from the die and the optics is modified to improve light extraction from the LED structure.

Laser-based light sources use a similar concept of "remote phosphor". The phosphor is placed at a distance far from the laser source hence reducing thermal effects and potential colour shifts.

Laser-based light sources might be operating in reflection mode, allowing for the remote phosphor to be placed on a reflective surface that can also act as a heat sink to effectively dissipate heat away from the phosphor.

Whereas LEDs efficacy has reached 100 lm/W (lumen per watt) to date, laser lighting is able to generate in 2015 about 170 lm/W.

### Laser based spot beams

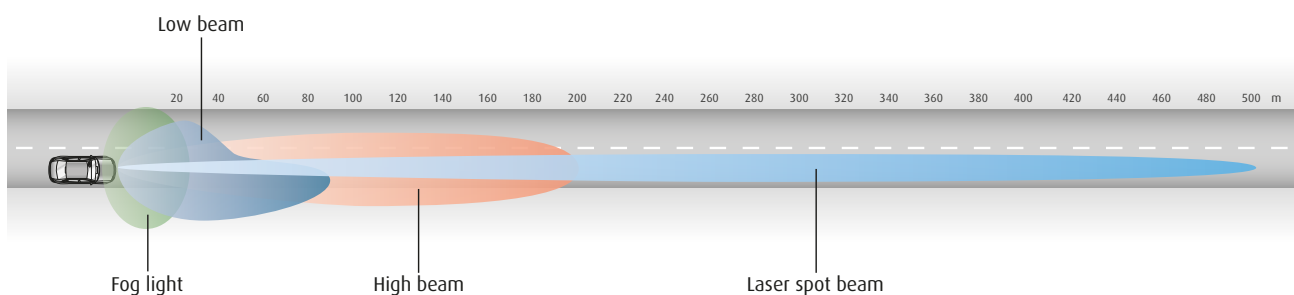



# 18

## Signalling

The signalling has a major function to vehicle safety, it permits distance communication to other vehicles by indicating presence and direction changes.



From rear combi-lamps, to fender-lamps, trunk-lamps and bumper-lamps, the signalling product-line offers a wide diversity of designs.

Similarly to the lighting function, the signalling function evolved a lot from historical lamp products to the most sophisticated laser etched and light-guide designs.

Lamps are cost effective, they are still used in many signalling applications. Will LEDs one day totally overcome the lamps? Yes it is very likely they will.

Technology is moving fast and Organic LEDs (OLEDs) could as well rise as one outsider for signalling, the future will tell us.

Valeo first introduced a rear lamp with LED technology for the Volkswagen Golf V in 2005.

<b>VOLKSWAGEN</b> [...]			
<b>Golf V Plus (2005-2009)</b>			
<b>01/2005 → 01/2009</b>			
			<b>088911 088912</b> <small>5M0945095N 5M0945096N</small>

Rearlamp for Volkswagen - Golf V with LED technology

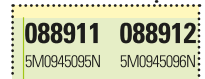

## 18.1. The trend for a massive use of LEDs is engaged

From traditional position lights with tungsten lamps, signalling functions have evolved enormously and LED technology has been a major driver for this.



LEDs offer many advantages:

- Short time response
- High efficacy / lower energy consumption
- Longer life time
- No frontal Infra Red radiations
- Higher design flexibility
- More compact for improved space efficiency
- Dimmable control.

Designers have taken advantage of advances in LED technology.

LED optical designs combine, lenses, light guides, reflectors, they offer a wide styling diversity for unique brand signatures.

LEDs can be set very near to the outer lens (no Infra Red) allowing a minimum depth and a maximum flexibility in shapes.

## 18.2. MICROOPTICS styling breakthrough for front & rear night-time signature

Computer optics simulation permits to design complex light guides, Valeo has introduced a new Microoptics technology based on LEDs and light guides, which can be used to create a homogeneously illuminated surface appearance.

Valeo Microoptics technology offers greater design freedom such as differentiated daytime and night-time styling. It can be applied both to front and rear exterior lighting, even if they have complex shapes.



Microoptics technology advantages:

- Styling differentiation
- Illumination of entire or partial surface
- Homogeneous lit surface for night-time signature
- Rear and Front (Position Light) functions
- Compatible with standard LED sources and plastic materials (PMMA, PC)
- Signal functions (Multi -LED, Mono-LED or Tungsten bulbs) can be placed behind the lit screen

# 18. Signalling

## 18.3. Photometry in signalling functions

As for lighting, the signalling devices have to comply with photometric specifications.

European Commission standard (ECE R.) set photometric limits and all measurement conditions.

Minimum and maximum intensity values are defined in various directions of measurement, the minimum intensities are defined as a percentage of the minimum required in the axis for each lamp (100% in the direction  $H = 0^\circ$  and  $V = 0^\circ$ ).

The main photometric features are detailed here under.

- ECE R07 (front and rear position-lamps, stop-lamps and end-outline marker lamps).

### Stop lamps

		← H →						
		20°	10°	5°	0°	5°	10°	20°
V	UP							
	10°			12		12		
	5°	6	12		42		12	6
	0°		21	54	<b>60 cd</b>	54	21	
	5°	6	12		42		12	6
	10°			12		12		
DOWN								

### Tail lamps

		← H →						
		20°	10°	5°	0°	5°	10°	20°
V	UP							
	10°			0.8		0.8		
	5°	0.4	0.8		2.8		0.8	0.4
	0°		1.4	3.6	<b>4 cd</b>	3.6	1.4	
	5°	0.4	0.8		2.8		0.8	0.4
	10°			0.8		0.8		
DOWN								

- ECE R06 (turn indicators lamps).

		← H →						
		20°	10°	5°	0°	5°	10°	20°
V	UP							
	10°			10		10		
	5°	5	10		35		10	5
	0°		17.5	45	<b>50 cd</b>	45	17.5	
	5°	5	10		35		10	5
	10°			10		10		
DOWN								

● ECE R38 (rear fog lamps).

The intensity along the H and V axes, between 10° to the left and 10° to the right and between 5° up and 5° down, shall not be less than 150 cd.

The intensity of the light emitted in all directions in which the light(s) can be observed shall not exceed 300 cd for a device with steady luminous intensity and 840 cd for a device with variable luminous intensity.

		H				
		10°	5°	0°	5°	10°
V	UP					
	5°			150		
			75		75	
	0°	150		<b>150 cd</b>		150
	5°		75		150	
	DOWN			150		

● ECE R77/7 (parking lamps).

		H						
		20°	10°	5°	0°	5°	10°	20°
V	UP							
	10°			0.4		0.4		
	5°	0.2	0.4		1.4		0.4	0.2
	0°		0.7	1.8	<b>2 cd</b>	1.8	0.7	
	5°	0.2	0.4		1.4		0.4	0.2
	DOWN							

● ECE R87 (Daytime Running Lamps).

The luminous intensity of the light emitted by each lamp shall not be less than 400 cd in the axis of reference.

		H						
		20°	10°	5°	0°	5°	10°	20°
V	UP							
	10°			80	80	80		
	5°	40	80		280		80	40
	0°	100	280	360	<b>400 cd</b>	360	280	100
	5°	40	80		280		80	40
	DOWN							

● ECE R23 (reversing lamps).

The intensity along the axis of reference shall be not less than 80 cd.

The intensity of the light emitted in all directions in which the light can be observed shall not exceed: 300 cd in directions in or above the horizontal plane; and, in directions below the horizontal plane: 600 cd between between the horizontal plane and 5° down and 8000 cd below 5° down.

		H						
		45° ext.	30°	10°	0°	10°	30°	45° int.
V	UP							
	10° Up			10	15	10		
	5°	15		20	25	20		15
	0°	15	25	50	<b>80 cd</b>	50	25	15
	5° Down	15	25	50	80	50	25	15
	DOWN							

# 18. Signalling

## 18.4. Signalling gets smarter!

From traditional signalling functions, new technologies are now appearing on the market, the emergency braking signal is one of them.

Cars today, are able to give better braking performance due to improvements in braking technology. This is a major improvement in road safety but to combat potential rear-end collisions, this needs to be combined with a new type of signalling to warn other road users more effectively.

"Emergency braking signal" is a system to indicate to other road users behind the vehicle that a high deceleration force has been applied by the vehicle in front relative to the prevailing road conditions.

The emergency stop signal shall be given by the simultaneous operation of all the stop or direction-indicator lamps, all the lamps should flash together at a frequency of 4 flashes per second (only LEDs can perform this).

The emergency braking signalling is activated and deactivated automatically, it may be operated either:

- From a prediction of the vehicle deceleration resulting from the hard braking with a deceleration equal to or above 6 m/s per second (22 km/h reduction per second).
- When the antilock system is fully cycling at a speed above 50 km/h.

The emergency braking signal shall be de-activated when the deceleration has fallen below 2.5 m/s per second (9 km/h reduction per second) or when the antilock system is no longer fully cycling.

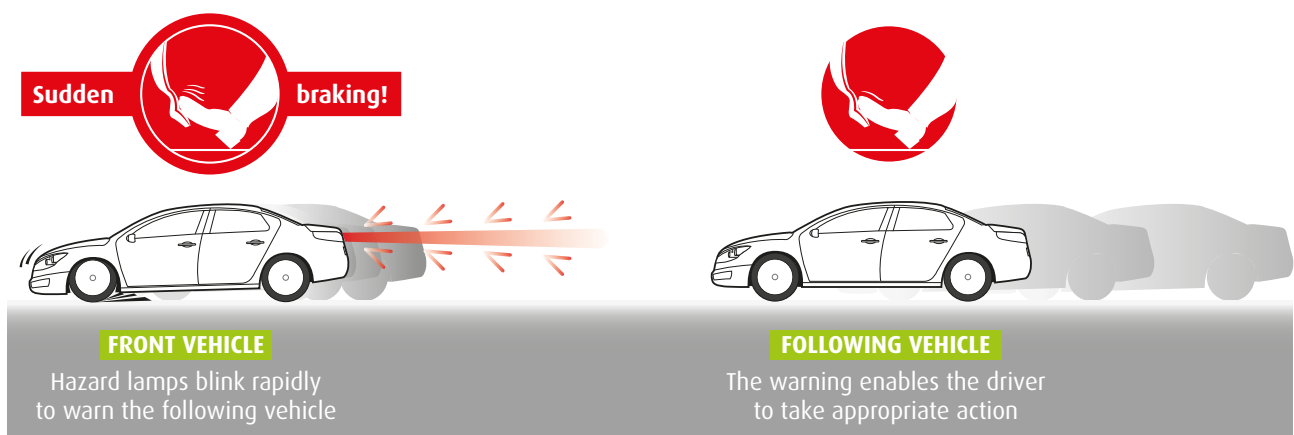

# 19

## Lighting systems servicing

All Original Equipment lighting systems must be homologated according to strict regulations; this applies from the light source to projector design and projector fitting on the vehicle.

For long lasting performances it is important to follow some rule regarding the vehicle lighting servicing.

### 19.1. Light source selection

The position of the light source is fundamental to light projection onto the road. By light source, it should be understood the area where light is emitted from the source. This means it is either a filament, an arc or a LED chip.

Little variations on the source position generate a huge difference on the light projection. This is why all light sources are specified exactly and in particular the tolerances on the light source positioning in the lamp.

In addition to the position of the filament inside the bulb, the axis of the lamp itself and its reference plane must be precisely adjusted to the projection element. This is part of the reason why Xenon and LED conversion fit kits are not legally authorized as they are not homologated and totally modify the light distribution inside the projector.

# 19. Lighting systems servicing

## 19.2. Light source installation

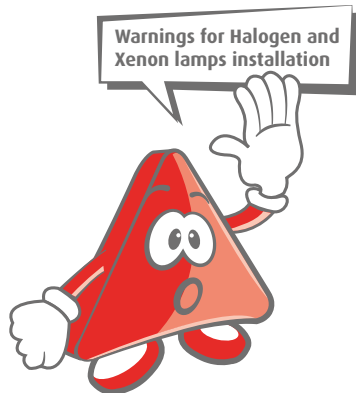

### Risk of being burnt.

- Turn power off before installing bulb.
- Allow bulb to cool before handling.

### Bulb may shatter and cause injury if broken.

- Wear safety glasses and gloves when handling a bulb.
- Do not use a bulb if its outer glass is scratched or broken.

### Risk of electric shock.

- Turn power off before inspection, installation or removal.
- Do not use a bulb where it is directly exposed to water or the atmosphere and it is not in an enclosed fixture.
- Unexpected bulb failure may cause injury, fire, or property damage.
- Do not exceed rated wattage or voltage.
- Do not touch glass with bare hands.
- Use only properly rated ballast.
- Operate bulb only when it is fitted in its specified position.
- Do not store flammable materials in the vicinity of the bulb.
- Do not turn on the bulb until fully installed.

## 19.3. Fitting Xenon lamps

Xenon light sources need high voltage to be triggered. Depending on the Xenon generation fitting rules may slightly differ, but basic measures must be taken prior to manipulate and service Xenon system.



### High voltage

Twenty thousand volts (20 kV) are issued by the ballast and the ignitor during the Xenon lamp start-up, so it is essential to ensure that the system is fully disabled before undertaking a lighting maintenance procedure.

Some vehicles equipped with comfort functions may switch the lighting system according to key-entry or door-opening events, considering the variety of vehicles on the market **only a disconnected battery can totally secure operators from a 20 kV discharge.**

## 19.3.1. Ballast and ignitor installation

### Ballast and ignitor installation



Xenon lamps are high-voltage and high-current controlled with a 200 Hz frequency in steady state mode. Those signals can cause potential issues with other vehicle components from electronic interference.

To comply with automotive Electro Magnetic Compatibility (EMC), the whole system is shielded from the ballast unit to the lamp connector.

Care should be taken to properly plug in the connectors and wiring harness to avoid any EMC issues with other electronic components on the vehicle.

### Zoom on connector and EMC cable

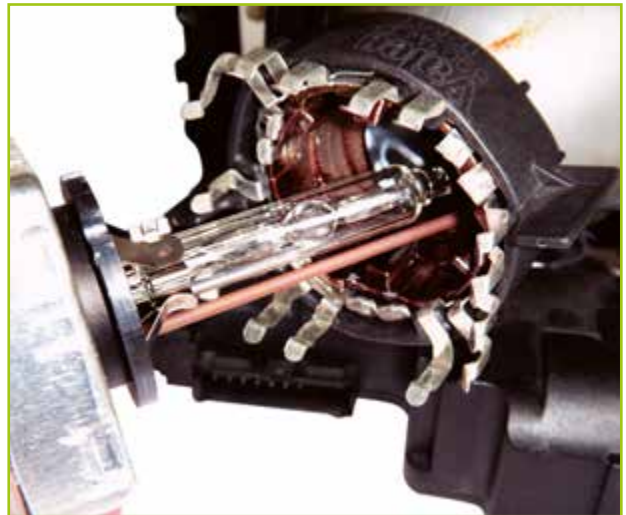



# 19. Lighting systems servicing

## 19.4. Aiming correction in workshops

The aiming angle is based on light projection at 25m. However, such a distance is not mandatory to adjust the headlamps or fog lamps in a workshop.

A dedicated Valeo garage tool permits to automatically diagnose and adjust the inclination angle, such optical tools require stringent installation conditions to work correctly.



**REGLOSCOPE™**

Valeo solution for complete lighting diagnosis

**Reasons to choose Valeo:**

- Diagnosis < 1 minute.
- Light and easy to use.
- Develop your lighting business.

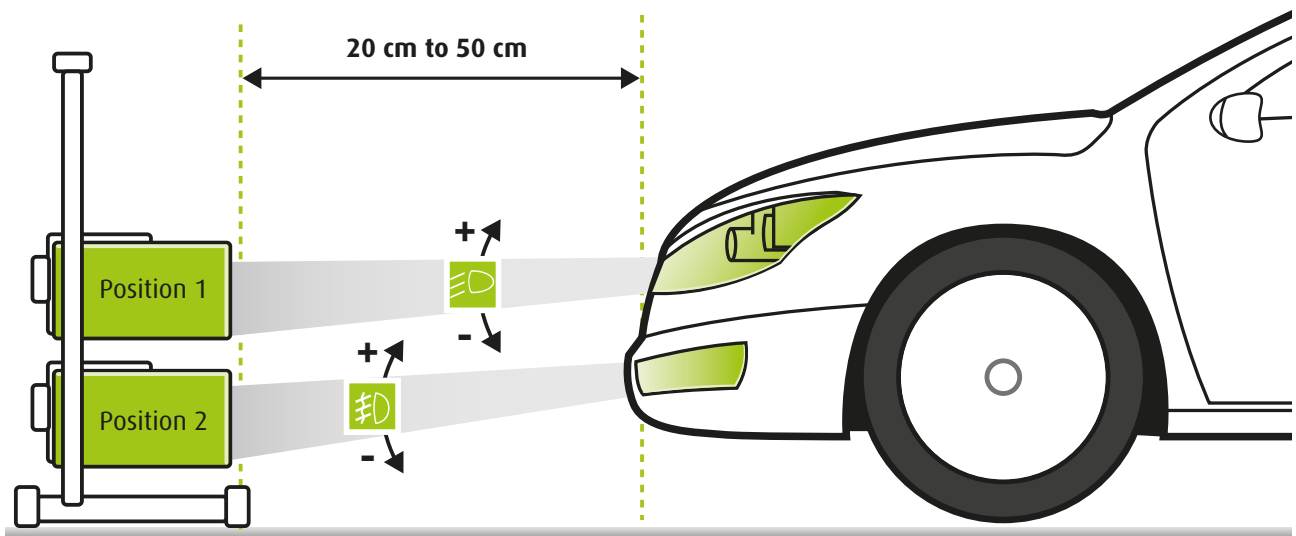

### 19.4.1. Measurement conditions

The ground on which measurements are made shall be as flat and horizontal as possible, so that the reproducibility of measurements of low beam inclination can be accurately assured.

During measurements, the ambient temperature shall be between 10 and 30 °C.

### 19.4.2. Vehicle preparation

Tires shall be inflated to the full-load pressure specified by the vehicle manufacturer.

The vehicle shall be fully replenished (fuel, water, oil) and equipped with all the accessories and tools specified by the manufacturer.

Full fuel replenishment means that the fuel tank shall be filled to not less than 90 per cent of its capacity.

The vehicle shall have the parking brake released and the gearbox in neutral.

### 19.4.3. Measuring AFS aiming

For AFS the same set-up is used as for standard headlamps.

The measurements shall be carried out with the AFS in its neutral state; the neutral state forces the system to "Classic" beam.

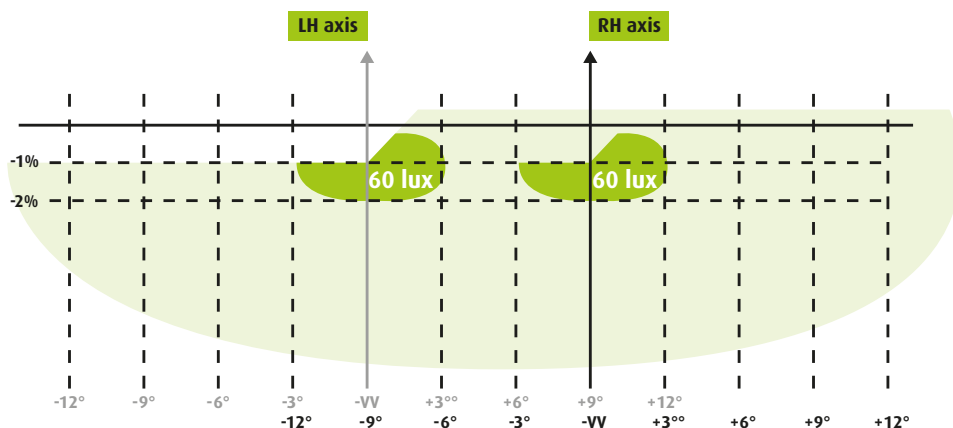



# Regloscope™

## Offer **complete headlamp diagnosis** with the Regloscope™

### Laser localisation

- Easy to position.

### Counterweight system

- Easy to handle.

### Photodiode centering system

- Optimal positioning assistance with user-friendly on-screen indications.

### LCD screen

- Simple visual indications and real-time measures.

### Integrated printer

- Providing a summary proving the quality of the operation.

### 2 modes

- Preventive control.
- Headlamps setting.

### 4 measures for 1 complete diagnosis

- Vertical levelling set-up.
- Luminous intensity.
- Dazzling.
- Lateral moving set-up.

Precise set-up with detection of failed bulbs and defective components to gain additional sales.



# REGLOSCOPE™

# 20

## Regulations and marking

Original equipment lighting systems are covered by numerous regulations that apply to each country.

The “E mark” indicates the country where the system has been approved; it is associated with a unique number per country.



An approval number is assigned to each type approved. The first two digits indicate the series of amendments incorporating the most recent major technical amendments made to the Regulation at the time of issue of the approval.

E1	Germany	E21	Portugal	E41	(vacant)
E2	France	E22	Russian Federation	E42	European union
E3	Italy	E23	Greece	E43	Japan
E4	Netherlands	E24	Ireland	E44	(vacant)
E5	Sweden	E25	Croatia	E45	Australia
E6	Belgium	E26	Slovenia	E46	Ukraine
E7	Hungary	E27	Slovakia	E47	South Africa
E8	Czech Republic	E28	Belarus	E48	New Zealand
E9	Spain	E29	Estonia	E49	Cyprus
E10	Serbia	E30	(vacant)	E50	Malta
E11	United Kingdom	E31	Bosnia and Herzegovina	E51	Republic of Korea
E12	Austria	E32	Latvia	E52	Malaysia
E13	Luxembourg	E33	(vacant)	E53	Thailand
E14	Switzerland	E34	Bulgaria	E54	(vacant)
E15	(vacant)	E35	(Kazakhstan)	E55	(vacant)
E16	Norway	E36	Lithuania	E56	Montenegro
E17	Finland	E37	Turkey	E57	(vacant)
E18	Denmark	E38	(vacant)	E58	Tunisia
E19	Romania	E39	Azerbaijan		
E20	Poland	E40	The former Yugoslav Republic of Macedonia		



# How to use Valeo lighting systems catalogue?



## Front Lighting Projecteurs Iluminación delantera Iluminação Dianteira Fanale Anteriore Voor Verlichting Front-Beleuchtung

## Rear lighting Feux arrière Función piloto posterior Função pisca posterior Fanale posteriore Achter Verlichting Heck-Beleuchtung

Car maker / model  
Marque / Modèle  
Marca/Modelo  
Marca/Modelo  
Costruttore / Modello  
Autofabrikant / model  
Fahrzeughersteller / Modell

Product type  
Type de produit  
Tipo de producto  
Tipo de produto  
Tipo di prodotto  
Product  
Produkt

Date of application  
Dates d'application  
Fecha de aplicación  
Data de aplicação  
Data di applicazione  
Bouwjaar  
Baujahr

Levelling device type  
Type de correcteur  
Corrector  
Corrector  
Tipo di correttore elettrico  
Type  
Hoogteregelaar  
Art der Leuchtweitereglung

Type of beam  
Type de faisceau  
Haz de luz  
Feixe de luz  
Tipo di fascio  
Type  
Type  
Lichtbundel  
Art des Lichts

Type of bulb  
Type de lampe  
Lâmpada  
Lâmpada  
Tipo di lampadina  
Type Lamp  
Type  
Glühlampe

Colour of lens  
Couleur de la glace  
Color de la luz  
Cór da luz  
Colore delle lenti  
Kleur van de Lens  
Farbe der Streuscheibe

Rear fog function  
Feu antibrouillard  
Anti-nevoeiro  
Anti-nevoeiro  
Fendinebbia posteriore  
Mistlamp achter  
Nebelschlussleuchte

Reverse function  
Feu de recul  
Marcha atrás  
Marcha atrás  
Retromarcia  
Achteruitrijfunctie  
Rückfahrleuchte

Brand & homologation number  
Marque & numéro d'homologation  
Número homologación  
Número homologação  
Marchio e numero di omologazione  
Merk en Homologatienummer  
Marke & Homologationsnummer

Left side  
Côté gauche  
Lado izquierdo  
Lado izquierdo  
Sinistra  
Linker zijde  
Linke Seite

Right side  
Côté droit  
Lado derecho  
Lado derecho  
Destra  
Rechter zijde  
Rechte Seite

Pour / For													
<b>RENAULT</b>		<b>Kangoo (2003&gt;)</b> (.../...)											
4x4		01/2005 → 10/2006											
				E+   HC/R   H4   CTL									
<p>Additional information on vehicle Informations supplémentaires Información adicional del vehículo Informação adicional do veículo Informazioni addizionali sul veicolo Extra voertuig informatie Zusatzinformation Fahrzeug</p>		<p>Product picture Image du produit Foto del producto Foto do produto Foto del prodotto Productafbeelding Produktfoto</p>		<p>Components included (or not included) Composants inclus / non inclus Componentes incluidos (o no incluidos) Componentes incluidos (ou não incluídos) Componenti inclusi (o non inclusi) Componenten inbegrepen (niet inbegrepen) Einzelteile enthalten (oder nicht enthalten)</p>		<p>Part number specific status: Statut spécifique Status de la referencia Status da referência Stato prodotto Specificke status referentienummer Status</p>		<p>OE part number Référence constructeur Referencia OES Referência OES Codice OE Origineel nummer OE Nummer</p>		<p>VS part number Référence VS Referencia VS Referência VS Codice VS Referentienummer VS VS Artikelnummer</p>			

# Tech'Care

## Delivering Technical Expertise

A range of technical and support services from your multi-specialist

### Technical Training

Training on all product lines  
For passenger cars  
and commercial vehicles  
Theoretical session and practical exercises  
Elearning on Valeo-Techassist.com

**A complete catalogue of  
technical training modules**

### Workshop tools

ClimFill® - air conditioning station  
Regloscope™ - Headlight beam  
adjustment  
Fastfill® - vacuum coolant re-filling  
Brake Fluid Tester - DOT boiling point tester

**Professional tools for  
diagnosis and maintenance**

# TECH' CARE

### Valeo technical support

**valeo-techassist.com**

Technical Bulletins  
Trouble shooting guidelines  
Assistance on FAQ's  
Fitting instructions

**Technical Hotline**

**Multi-Specialist approach  
for workshops**

Product demonstrations  
Tools demonstrations  
Technical Trainings  
Technical Assistance

### Technical Promoters

**CONTACT YOUR VALEO TECHNICAL  
PROMOTER FOR A DEMO !**



valeo added

Automotive technology, naturally







## The Lighting market

Car makers and component manufacturers have constantly developed new technologies to offer wider and longer field of vision and improved anticipation under all driving conditions. As a **lighting system expert**, Valeo has always been at the forefront of technology providing innovative solutions, in terms of efficiency, design and energy consumption. Valeo Service is proud to present to you its 2015 Lighting technical handbook as part of its renewed technical collection. From human visual perception, to light sources evolutions, regulations, photometric knowledge and Valeo latest technologies, this book will allow you to better understand lighting systems and their importance for road user safety.

### Valeo Service

70, rue Pleyel  
Cedex 93285 - Saint Denis - France  
Tel. : (+33)149 453 232  
Fax : (+33)149 453 201

[www.valeoservice.com](http://www.valeoservice.com)



Automotive technology, naturally