

RS SERIES

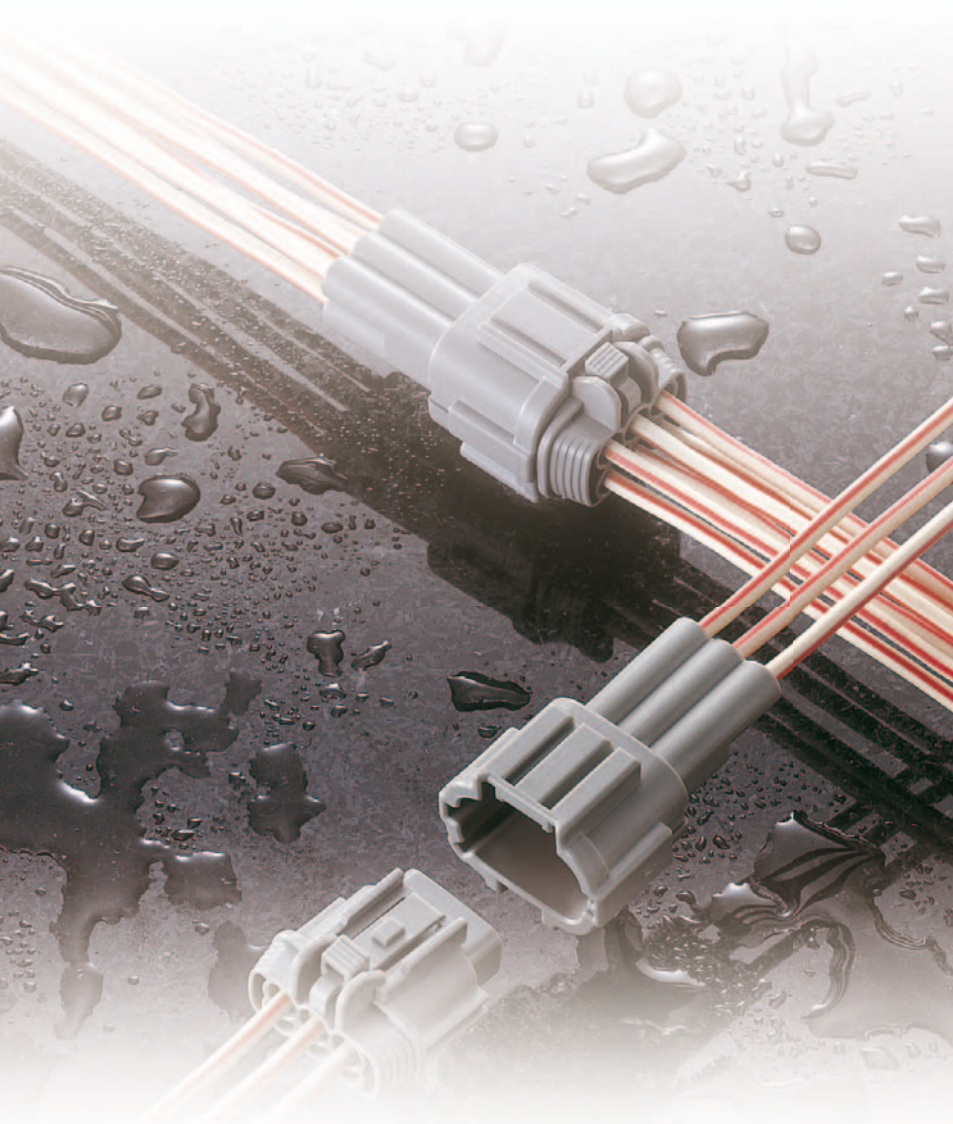

Features

RS series consists of a 2.3mm type classified according to terminal size, supporting use in a variety of control circuits and low power circuits.

- The RS-standard type connectors adopt an inertia locking system to prevent semi-engagement (this system is not incorporated in some connectors).

*Please contact our sales representative for product numbers.

- RoHS/ELV Compliant

特長

RSシリーズは、ターミナルサイズが2.3mmで構成されており、各種の制御回路並びに低パワー回路に対応することができます。

- RS-標準タイプコネクタは、コネクタの半嵌合が起きにくい慣性ロック方式です。(慣性ロック方式でないコネクタが一部あります。)

- RoHS/ELV対応

RS SERIES for STANDARD Type1

2.3mm (090)

Structure / 構造

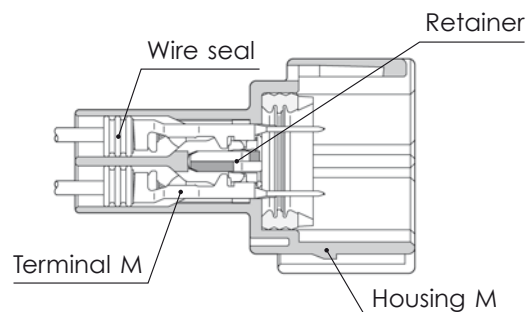
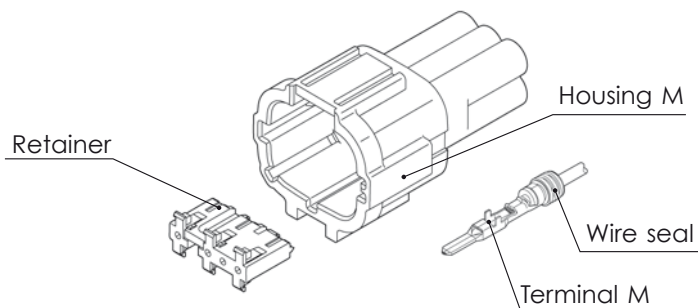

G-02

Connector M

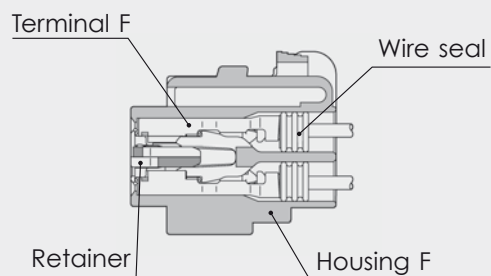
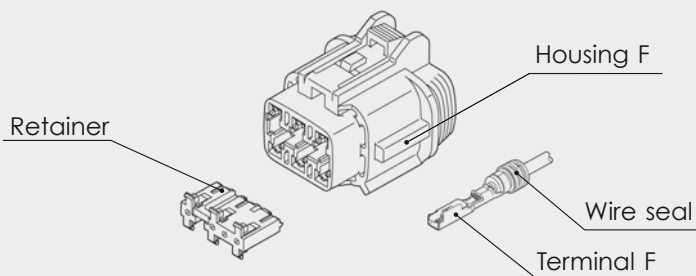

Connector F

2.3mm (090)

Terminal (UNIT : mm)

(S)

Cable size (mm ²) 適用電線サイズ	0.3~0.5
Material 材質	Brass 黄銅
Surface treatment 表面処理	Tin-plated Snメッキ

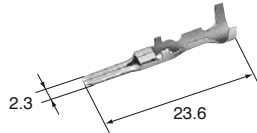
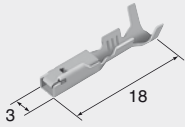
**M (8100-3803)****F (8240-0263)**

Cable size (mm ²) 適用電線サイズ	0.3~0.5
Material 材質	Heat-resistant copper alloy
Surface treatment 表面処理	Tin-plated Snメッキ

(S)**Au**

Cable size (mm ²) 適用電線サイズ	0.3~0.5
Material 材質	Brass 黄銅
Surface treatment 表面処理	Gold-plated Auメッキ

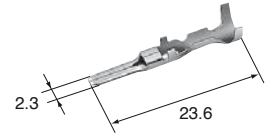
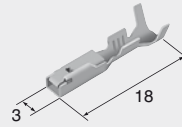
**M (8100-3805)****F (8240-0266)**

Cable size (mm ²) 適用電線サイズ	0.3~0.5
Material 材質	Heat-resistant copper alloy
Surface treatment 表面処理	Gold-plated Auメッキ

(M)

Cable size (mm ²) 適用電線サイズ	0.85~1.25
Material 材質	Brass 黄銅
Surface treatment 表面処理	Tin-plated Snメッキ

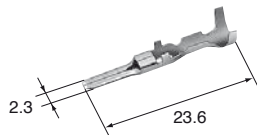
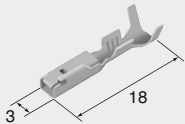
**M (8100-3804)****F (8240-0264)**

Cable size (mm ²) 適用電線サイズ	0.85~1.25
Material 材質	Heat-resistant copper alloy
Surface treatment 表面処理	Tin-plated Snメッキ

(M)**Au**

Cable size (mm ²) 適用電線サイズ	0.85~1.25
Material 材質	Brass 黄銅
Surface treatment 表面処理	Gold-plated Auメッキ

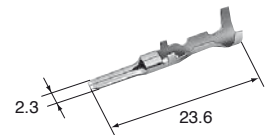
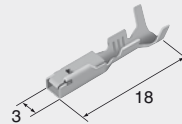
**M (8100-3806)****F (8240-0267)**

Cable size (mm ²) 適用電線サイズ	0.85~1.25
Material 材質	Heat-resistant copper alloy
Surface treatment 表面処理	Gold-plated Auメッキ

(L)

Cable size (mm ²) 適用電線サイズ	2.0
Material 材質	Brass 黄銅
Surface treatment 表面処理	Tin-plated Snメッキ

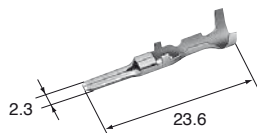
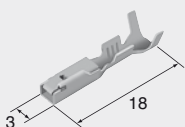
**M (8100-4172)****F (8240-0265)**

Cable size (mm ²) 適用電線サイズ	2.0
Material 材質	Heat-resistant copper alloy
Surface treatment 表面処理	Tin-plated Snメッキ

(L)**Au**

Cable size (mm ²) 適用電線サイズ	2.0
Material 材質	Brass 黄銅
Surface treatment 表面処理	Gold-plated Auメッキ

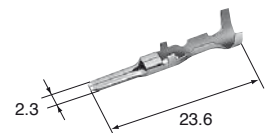
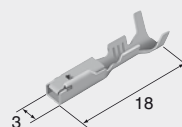
**M (8100-4173)****F (8240-0268)**

Cable size (mm ²) 適用電線サイズ	2.0
Material 材質	Heat-resistant copper alloy
Surface treatment 表面処理	Gold-plated Auメッキ

G-03

RS SERIES

2.3mm (090)

Wire seals (UNIT : mm)

The wire seals are common to M and F.

ワイヤシールはM、F共用です。

(M)

Cable size (mm ²) 適用電線サイズ	(AVSS/1.25)
Cable overall diameter (mm) 電線仕上り外径	2.0~2.4
Material 材質	Silicon シリコン
Color 色相	Violet 紫



(7165-0472)

2.3mm (090)

Dummy plugs (UNIT : mm)

- Dummy plugs are common to M and F.
- Dummy plugs are used to blind unused terminal holes.
- ダミー栓はM、F共用です。
- 不必要なターミナル穴を塞ぐために、ダミー栓を使用します。

(US)

(7165-0474)

Cable size (mm ²) 適用電線サイズ	(AVSS/0.3) (CAVUS/0.3~0.5)
Cable overall diameter (mm) 電線仕上り外径	1.0~1.4
Material 材質	Silicon シリコン
Color 色相	Orange 橙

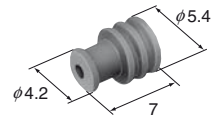

(S)

(7165-0473)

Cable size (mm ²) 適用電線サイズ	(AVSS/0.5~0.85) (CAVUS/0.85~1.25)
Cable overall diameter (mm) 電線仕上り外径	1.5~1.9
Material 材質	Silicon シリコン
Color 色相	Light Blue 淡青



(L)

(7165-0471)

Cable size (mm ²) 適用電線サイズ	(AVSS/2.0)
Cable overall diameter (mm) 電線仕上り外径	2.5~2.9
Material 材質	Silicon シリコン
Color 色相	Light Green 淡緑



(7165-1131)

Material 材質	Silicon シリコン
Color 色相	Blue 青

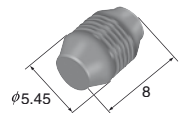

2.3mm (090)

Housing (UNIT : mm)

Ref: Terminal part No.
ターミナル参照頁 G-02

Ref: wire seal No.
ワイヤシール参照頁 G-04

Ref: Dummy plug No.
ダミー栓参照頁 G-04

Material
材質 PBT

※ Detail dimensions for mounting portion of the bracket are specified in the official drawing. Please contact our sales staff.

※ 固定用ブラケットに関しては、弊社営業担当にお問い合わせください。

1way

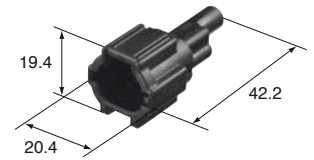
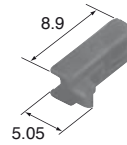

Retainer No. (6918-1773)

M (6188-0551) RS 01 MB

RS 01 FB **F (6185-0862)**

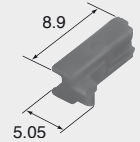
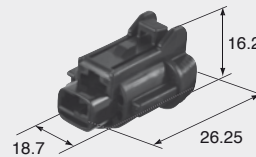

Retainer No. (6918-1773)

2way

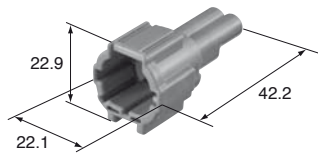
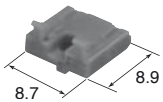

Retainer No. (6918-1774)

M (6188-0554) RS 02 MGY

RS 02 FGY **F (6185-0867)**

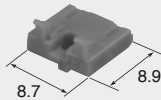
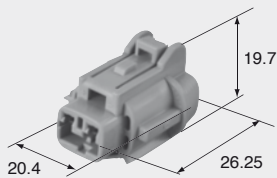

Retainer No. (6918-1774)

2way

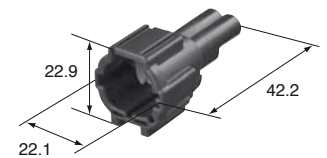
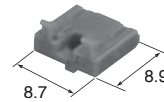

Retainer No. (6918-1774)

M (6188-0552) RS 02 MB

RS 02 FB **F (6185-0865)**

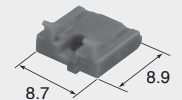
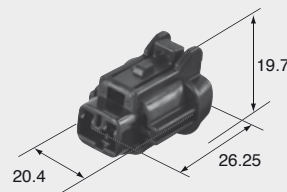

Retainer No. (6918-1774)

2way

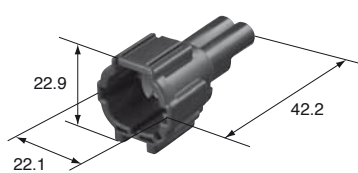
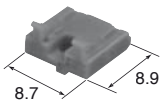

Retainer No. (6918-1774)

M (6188-0553) RS 02 MBR

M (6188-0663) RS 02 MBR-DGY

RS 02 FBR **F (6185-0866)**

RS 02 FBR-DGY **F (6185-1101)**

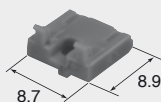
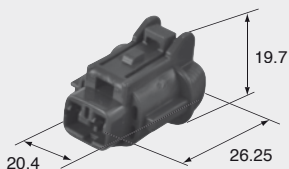

Retainer No. (6918-1774)

3way

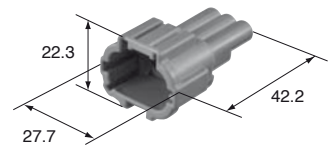
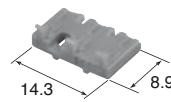

Retainer No. (6918-1775)

M (6188-0556) RS 03 MGY

RS 03 FGY **F (6185-0869)**

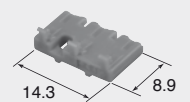
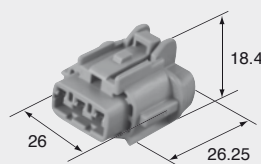

Retainer No. (6918-1775)

3way

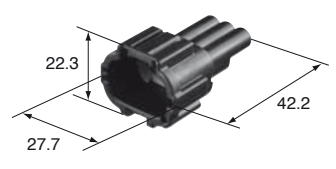
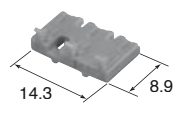

Retainer No. (6918-1775)

M (6188-0555) RS 03 MB

RS 03 FB **F (6185-0868)**

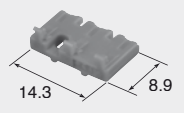
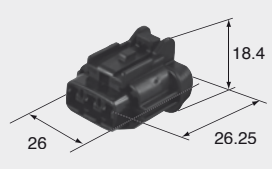

Retainer No. (6918-1775)

4way

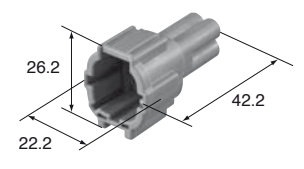
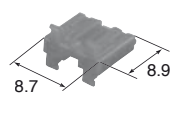

Retainer No. (6918-1776)

M (6188-0558) RS 04 MGY

RS 04 FGY-PR **F (6185-1171)**

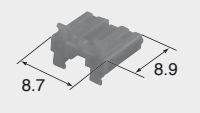
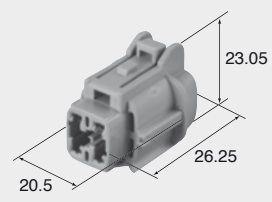

Retainer No. (6918-1776)

4way

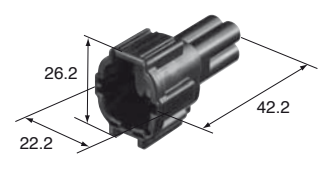
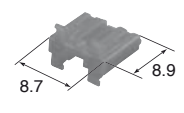

Retainer No. (6918-1776)

M (6188-0557) RS 04 MB

RS 04 FB-PR **F (6185-1169)**

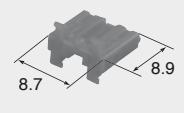
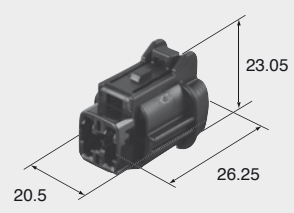

Retainer No. (6918-1776)

6way

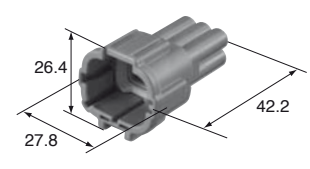
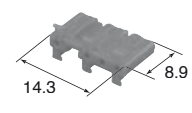

Retainer No. (6918-1779)

M (6188-0560) RS 06 MGY

RS 06 FGY-PR **F (6185-1175)**

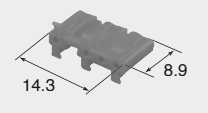
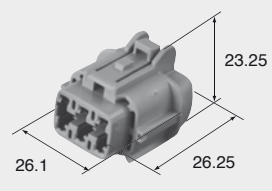

Retainer No. (6918-1779)

6way

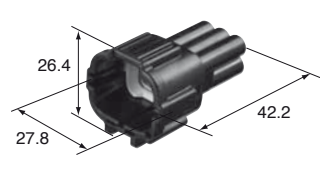
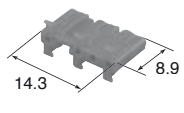

Retainer No. (6918-1779)

M (6188-0559) RS 06 MB

RS 06 FB-PR **F (6185-1173)**

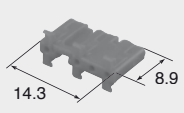
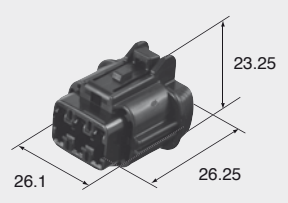

Retainer No. (6918-1779)

8way

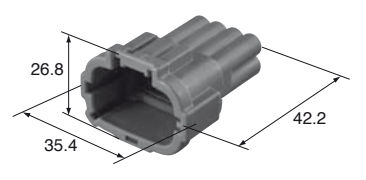
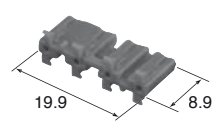

Retainer No. (6918-1780)

M (6188-0738) RS 08 MGY-PR

RS 08 FGY-PR **F (6185-1179)**

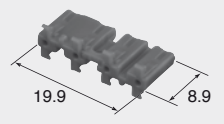
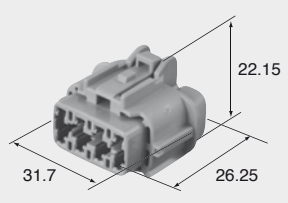

Retainer No. (6918-1780)

8way

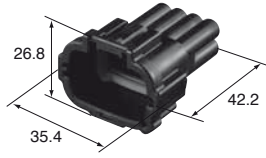
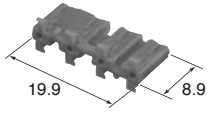

Retainer No. (6918-1780)

M (6188-0736) RS 08 MB-PR

RS 08 FB-PR **F (6185-1177)**

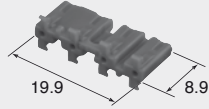
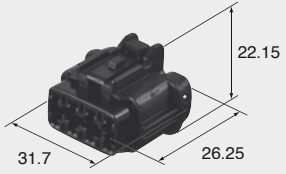

Retainer No. (6918-1780)

RS SERIES for STANDARD Type2

2.3mm (090)

Structure / 構造

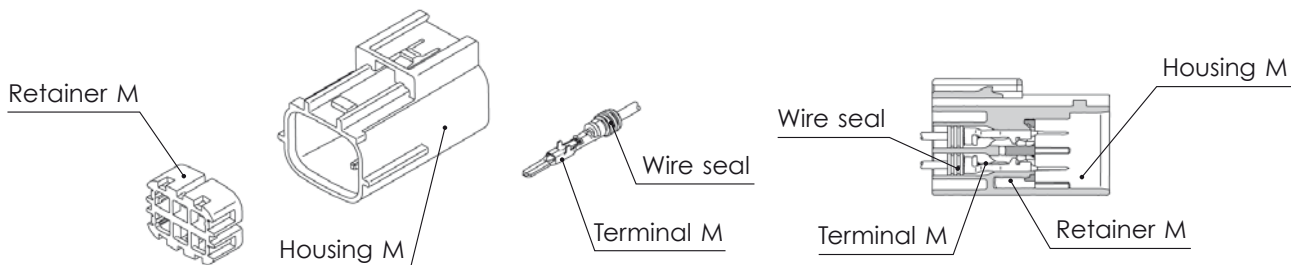

Connector M

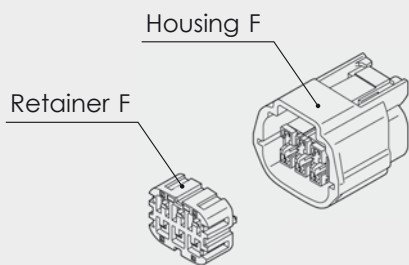

Connector F

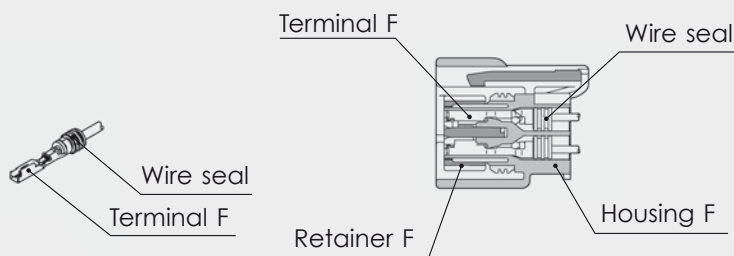

2.3mm (090)

Housing (UNIT : mm)

Ref: Terminal part No. G-02
ターミナル参照頁

Ref: wire seal No. G-04
ワイヤシール参照頁

Ref: Dummy plug No. G-04
ダミー栓参照頁

Material PBT
材質

2way

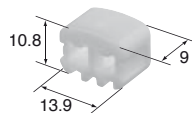

Retainer No. (6918-1653)

M (6181-0515) RS 02 MSB

M (6181-0670) RS 02 MSB-B

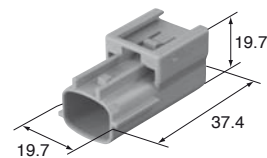

RS 02 FSB **F (6189-0951)**

RS 02 FSB-B **F (6189-1107)**

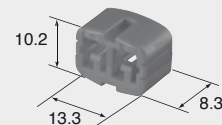
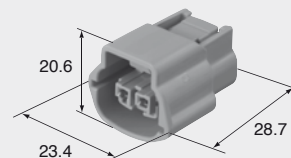

Retainer No. (6918-1651)

2way

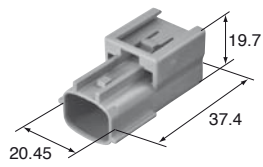
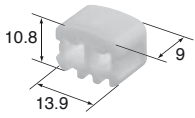

Retainer No. (6918-1653)

M (6181-0532) RS 02 MLGY

RS 02 FLGY **F (6189-0950)**

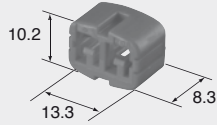
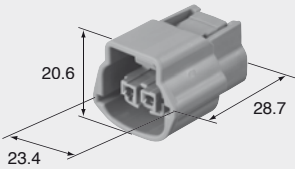

Retainer No. (6918-1651)

3way

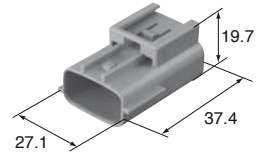
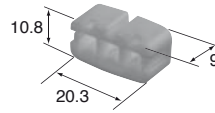

Retainer No. (6918-1654)

M (6181-0516) RS 03 MSB

M (6181-0671) RS 03 MSB-GY

RS 03 FSB

F (6189-0928)

RS 03 FSB-GY **F (6189-1104)**

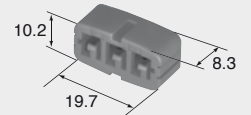
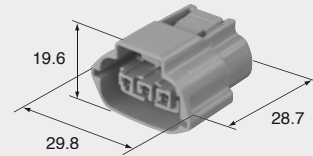

Retainer No. (6918-1652)

4way

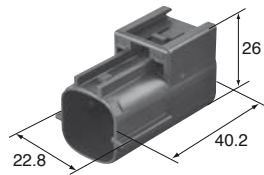
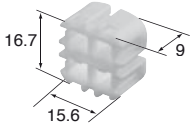

Retainer No. (6918-1598)

M (6181-0513) RS 04 MG

M (6181-0668) RS 04 MG-GY

RS 04 FG **F (6189-0929)**

RS 04 FG-GY **F (6189-1105)**

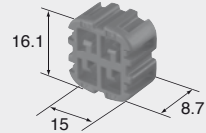

Retainer No. (6918-1599)

4way

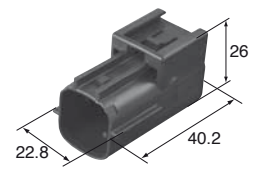
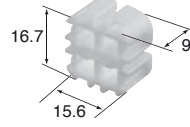

Retainer No. (6918-1598)

M (6181-0514) RS 04 ML

M (6181-0669) RS 04 ML-B

RS 04 FL

F (6189-0930)

RS 04 FL-B **F (6189-1106)**

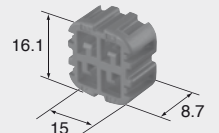

Retainer No. (6918-1599)

6way

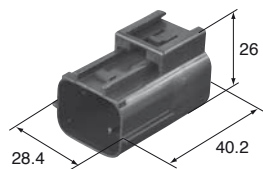
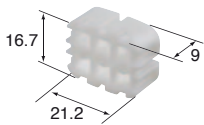

Retainer No. (6918-1600)

M (6181-0511) RS 06 MG

M (6181-0665) RS 06 MG-DGY

RS 06 FG **F (6189-0766)**

RS 06 FG-DGY **F (6189-1102)**

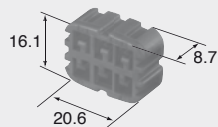

Retainer No. (6918-1601)

6way

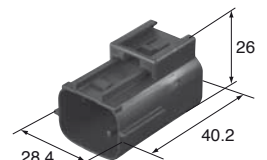
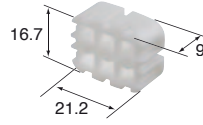

Retainer No. (6918-1600)

M (6181-0536) RS 06 ML

M (6181-0664) RS 06 ML-B

RS 06 FL

F (6189-0847)

RS 06 FL-B **F (6189-1103)**

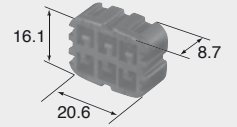
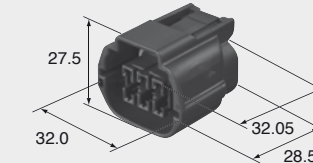

Retainer No. (6918-1601)

8way

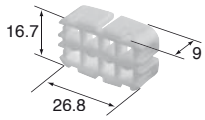

Retainer No. (6918-1602)

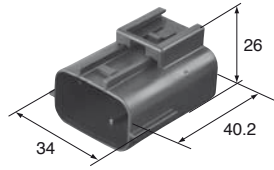

M (6181-0512) RS 08 MG

M (6181-0667) RS 08 MG-GY

RS 08 FG **F (6189-0954)**

RS 08 FG-GY **F (6189-1108)**

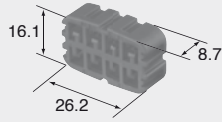

Retainer No. (6918-1603)

8way

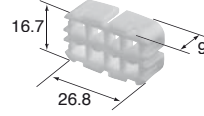

Retainer No. (6918-1602)

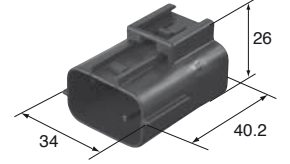

M (6181-0522) RS 08 ML

M (6181-0666) RS 08 ML-B

RS 08 FL **F (6189-0955)**

RS 08 FL-B **F (6189-1109)**

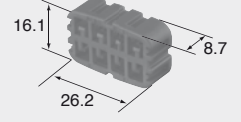

Retainer No. (6918-1603)

RS SERIES for E-RS

2.3mm (090)

Structure / 構造

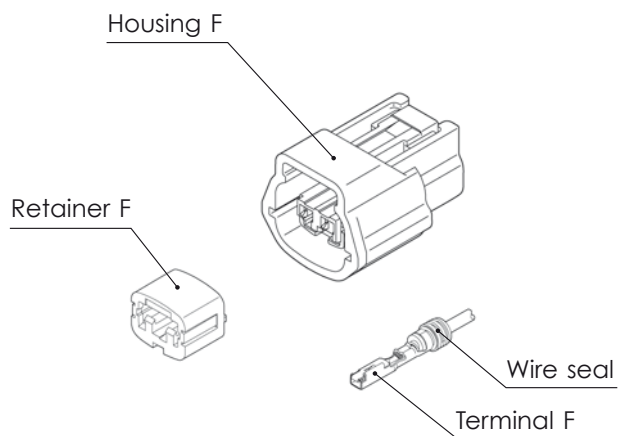

Mating portion
(Connector M)



Connector F
(After setting retainer)

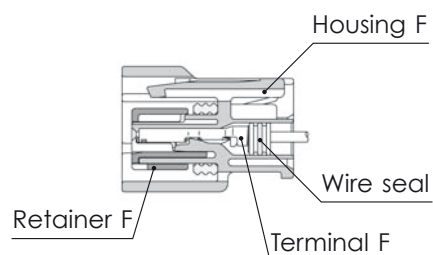

G-11

RS SERIES

2.3mm (090)

Housing (UNIT : mm)

Ref: Terminal part No. G-02
ターミナル参照頁

Ref: wire seal No. G-04
ワイヤシール参照頁

Ref: Dummy plug No. G-04
ダミー栓参照頁

Material PBT
材質

1way



E 01 FGY-RS **F (6098-2329)**

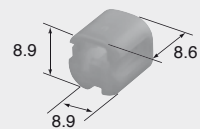

Retainer No. (6918-1636)

2way

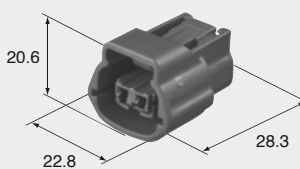

E 02 FGY-RS **F (6189-0772)**

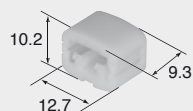

Retainer No. (6918-1594)

2way

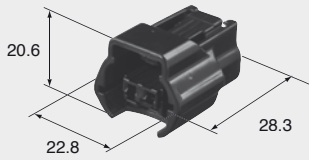

E 02 FB-RS **F (6189-0773)**

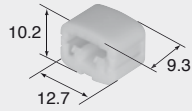

Retainer No. (6918-1594)

2way

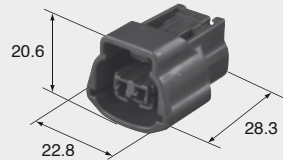

E 02 FBR-RS **F (6189-0774)**

E 02 FBR-RS-GY **F (6189-1093)**

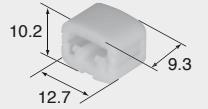

Retainer No. (6918-1594)

2way

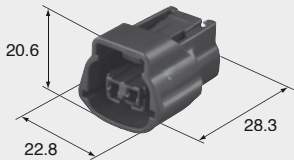

E 02 FG-RS **F (6189-0775)**

E 02 FG-RS-LGY **F (6189-1094)**

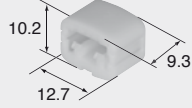

Retainer No. (6918-1594)

2way

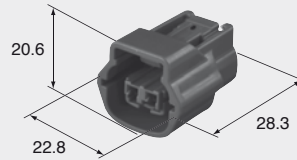

E 02 FR-RS **F (6189-0776)**

E 02 FR-RS-GY **F (6189-1095)**



Retainer No. (6918-1594)

2way



E 02 FL-RS **F (6189-0777)**

E 02 FL-RS-LGY **F (6189-1096)**



Retainer No. (6918-1594)

2way

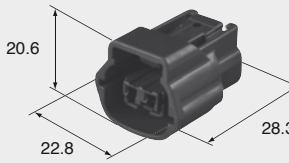

E 02 FPU-RS **F (6189-0778)**

E 02 FPU-RS-B **F (6189-1097)**



Retainer No. (6918-1594)

3way

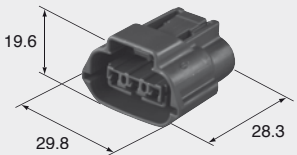

E 03 FGY-RS **F (6189-0779)**



Retainer No. (6918-1595)

3way

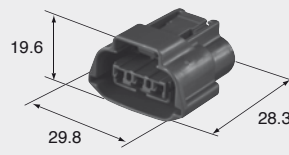

E 03 FBR-RS **F (6189-0780)**

E 03 FBR-RS-B **F (6189-1098)**

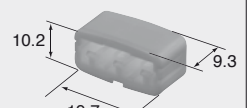

Retainer No. (6918-1595)

4way

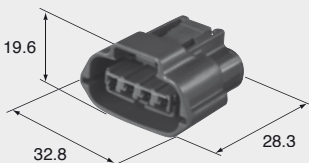

E 04 FGY-RS **F (6189-0781)**



Retainer No. (6918-1596)

4way



E 04 FBR-RS **F (6189-0782)**

E 04 FBR-RS-LGY **F (6189-1099)**

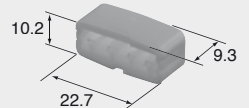

Retainer No. (6918-1596)

5way

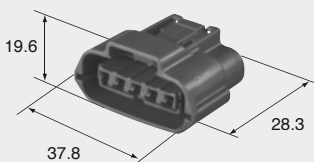

E 05 FGY-RS **F (6189-0848)**

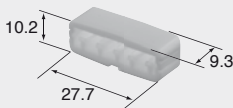

Retainer No. (6918-1604)

5way

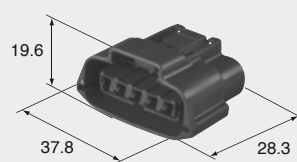

E 05 FBR-RS **F (6189-0783)**

E 05 FBR-RS-B **F (6189-1100)**



Retainer No. (6918-1604)

6way

E 06 FGY-RS **F (6189-7393)**

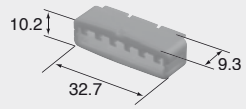
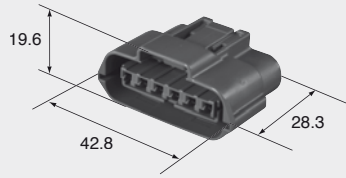

Retainer No. (6918-1597)