

Series
84
Halo Compact.

www.eao.com



Series 84

Halo Compact.

EAO introduces the Halo Compact, a unique and newly developed multi-functional illumination switching element which has the ability to provide the most common status indication features in a single all-in-one solution.

The new Series 84 Halo Compact provides a simple way to package up to eight different status indications into a single unit making this multi-functional, illuminated switching element suitable for a wide range of market segments such as special vehicles, machinery control panels and public environments.

This innovative, all-in-one solution is another option within EAO's award winning Series 84. These switching elements have the ability to provide ring illumination of five different colours within the lens. Additionally a white LED can illuminate the centre of the lens.

The Halo Compact can be used to control up to eight different pre-configured lighting sequences thus providing an effective way to manage multiple functions within a single switch.

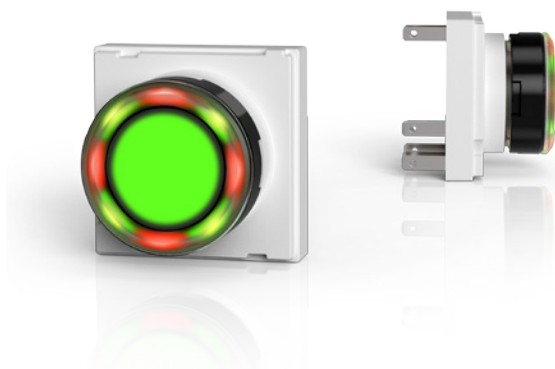

Typical Applications

- Machinery control panels
- Operator controls in special vehicles
- Medical equipment
- Public information kiosks and vending machines
- Access control and emergency call boxes
- Instruments for audio and video technology
- Many further applications

Materials

- Housing
 - Ixef 1521 nature (PA)
 - Hotmelt (sealing compound)
- Material of contact
 - Silver alloy, gold-plated

The materials used comply with the high EAO standards relating to quality, functional safety, service life and design.

Mechanical characteristics

- Terminals
 - Soldering / plug-in terminals 2.8 x 0.8 mm (solderable)
- Actuating force
 - 4.0 N \pm 0.2 N (measured at the lens)
- Actuating distance
 - ~0.5 mm
- Mechanical lifetime
 - \geq 1 million cycles of operations

Switching element

- Short-travel snap-action switching system with two independent contact points and tactile operation
- Number of contacts
 - One normal open contact

Output

- Electronic high-side switch

Operating voltage

- 24 VDC \pm 10 %
- Max. 100 mA

Current consumption

- < 80 mA

Advantages.

- The all-in-one solution for commonest status indications
- Eight pre-configured light sequences
- Five different LED colours (red, green, yellow, white and blue)
- Top of the range version with bi-colour LED illumination
- Integrated electronic switch for maintained action

Degree of protection

- IP67 front protection
(with actuator Part No. 84-1081.7 and 84-0080.7)

Ambient conditions

- Storage temperature
–40°C to +85°C
- Operating temperature
–25°C to +70°C

Pre-configured light sequences

- Full illumination
- Blinking (interval: 1 second)
- Rotating/chasing
(one full rotation per second)
- Process (changeover a group of 4 LEDs per second)

Special feature

Integrated electronic switch for maintained action of illuminated pushbuttons (High-side switch)

LED-colours

All versions available with eight SMD LEDs for halo illumination plus one single LED (3mm) for central illumination. The following variants are available:

- 8 x red LEDs + 1 white single LED
- 8 x green LEDs + 1 white single LED
- 8 x yellow LEDs + 1 white single LED
- 8 x white LEDs + 1 white single LED
- 8 x blue LEDs + 1 white single LED
- 8 x red/green Bi-colour LEDs + 1 white single LED

Standards and directives

CE, ESD

Switch configuration

A complete switch requires a halo compact programmable switch actuator body (transparent) and a lens. If the switch needs lens illumination in addition then a translucent plastic lens or aluminium lens with a window is required.

Use Halo Compact with illuminated push-button actuator (Part No. 84-1081.7) or with the indicator actuator (Part No. 84-0080.7).

The illumination style is selected by the connection of 24V to the pins.

Mounting

Quick and easy to mount: First connect cables to the non-mounted Halo Compact switching element, then plug to actuator (dismounting tool Part No. 84-918).

Dimensions

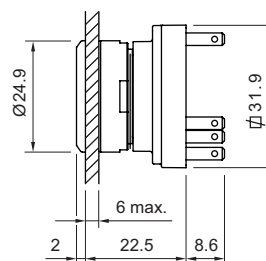

Terminals

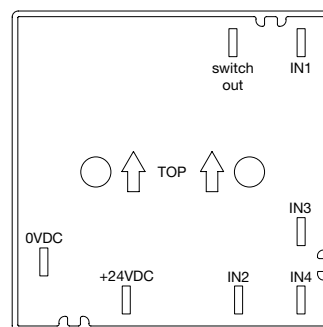

EAO Contact.

Your centre of excellence.

Headquarters

EAO Holding AG
Tannwaldstrasse 88
CH-4600 Olten
Telephone +41 62 286 91 11
info@eao.com

Manufacturing Companies

Switzerland
EAO AG
Tannwaldstrasse 88
CH-4600 Olten
Telephone +41 62 286 91 11
info@eao.com

EAO Systems AG
Tannwaldstrasse 88
CH-4600 Olten
Telephone +41 62 286 91 11
sales.esy@eao.com

China
EAO (Guangzhou) Ltd.
3/F, Block G4, Guangzhou
South China New Materials
Innovation Park
31 Kefeng Road,
Guangzhou Science City
CN-Guangzhou, PRC
Telephone +86 20 322 903 90
sales.ecn@eao.com

Germany
EAO Automotive GmbH & Co. KG
Richard-Wagner-Straße 3
DE-08209 Auerbach/Vogtland
Telephone +49 3744 8264 0
sales.esa@eao.com

North America
EAO Corporation
One Parrott Drive
Shelton
US-CT 06484
Telephone +1 203 951 4600
sales.eus@eao.com

Sales Companies

China
EAO (Guangzhou) Ltd.
RM 3A03, 3A/F, Block A,
Guangzhou
International Business
Incubator Centre
3 Ju Quan Lu,
Guangzhou Science City
CN-Guangzhou, PRC
Telephone +86 20 322 903 90
sales.ecn@eao.com

EAO (Shanghai) Office
Rm. 403, Block 5#,
CIFI Century Square, Lane 28,
NO. 21, Danba Road,
Putuo District
CN-Shanghai PRC
Telephone +86 21 609 507 17
sales.ecn@eao.com

France
EAO France SAS
5, rue Henri François
FR-77330 Ozoir-la-Ferrière
Telephone +33 1 64 43 37 37
sales.efr@eao.com

**Germany, Austria,
Poland, Czech Republic**
EAO GmbH
Langenberger Straße 570
DE-45277 Essen
Telephone +49 201 8587 0
sales.ede@eao.com

Hong Kong (Asia Pacific)
EAO (Far East) Ltd.
Unit A1, 1/F, Block A
Tin On Industrial Building
777 Cheung Sha Wan Road
Lai Chi Kok, Kln
HK-Hong Kong
Telephone +852 27 86 91 41
sales.ehk@eao.com

Italy
EAO Italia S.r.l.
Centro Direzionale Summit –
Plazzo D1
Via Brescia, 28
IT-20063 Cernusco sul Naviglio (MI)
Telephone +39 029 247 1934
sales.eit@eao.com

Japan
EAO Japan Co. Ltd.
Net 1 Mita Bldg. 3F
3-1-4 Mita Minato-ku
JP-Tokyo 108-0073
Telephone +81 3 5444 5411
sales.esj@eao.com

Netherlands, Belgium
EAO Benelux B.V.
Kamerlingh Onnesweg 46
Postbus 544
NL-3300 AM Dordrecht
Telephone +31 78 653 17 00
sales.enl@eao.com

North America
EAO Corporation
One Parrott Drive
Shelton,
US-CT 06484
Telephone +1 203 951 4600
sales.eus@eao.com

Sweden
EAO Svenska AB
Slakthusgatan 9
SE-121 62 Johanneshov
Telephone +46 8 683 86 60
sales.esw@eao.se

Switzerland
EAO Schweiz AG
Tannwaldstrasse 86
CH-4600 Olten
Telephone +41 62 286 95 00
sales.ech@eao.com

United Kingdom
EAO Ltd.
Highland House
Albert Drive
Burgess Hill,
GB-West Sussex RH15 9TN
Telephone +44 1444 236 000
sales.euk@eao.com