

Relays

Mini relays F7

Characteristic quantities

| | | |
|--------------------------|--------------------------|------------------------|
| Rated voltage | U_N | 24 V |
| Test voltage | U_P | 500 V _{-eff} |
| Upper limit temperature | ϑ_{\max} | 155 °C |
| Thermal resistance | R_{ϑ} | 40 K/W |
| Ambient temperature | ϑ_{amb} | -40 °C...+85 °C |
| Max. switching frequency | $f_{S\max}$ | 20 Hz |
| Response time (typ.) | t_{OP} | 7,5 ms |
| Graphical symbol | | See connection diagram |

Relays

Mini relays F7

NO relays

BOSCH
Part number Tyco
VW-Part number

0 986 332 002
V23134-J0052-X300
8DO 951 253

Technical data for contact side

| | | |
|---------------------------------------------|-----------------------------------|------------------------------|
| Contact material | | AgSnO ₂ |
| Minimum recommended current | $I_{Smin} (U_s = 13,5 V)$ | 1 A |
| Max. switching current ²⁾ - Make | I_{Smax} on ³⁾ / off | 240 A / 70 A |
| Limiting continuous current - Make | I_{SN} at 23 °C / 85 °C | 70 A / 50 A |
| Voltage drop - Make (typ.) | 10 A contact current | 10 mV |
| Increase in coil temperature (typ.) | 10 A contact current | 2 K |
| Mechanical endurance (without load) | | > 1 x 10 ⁷ cycles |
| Electrical endurance ⁴⁾ | | > 2 x 10 ⁵ cycles |

²⁾ The values apply to a resistive or inductive load with suitable spark suppression. ³⁾ This current may flow for a maximum of 3 s for a make / break ratio of 1:10.

⁴⁾ For a resistive load 70 A, $U_s = 13.5 V$ load voltage

Technical data for energizing side

| | | |
|-------------------------------|---------------|------------|
| Operate voltage ¹⁾ | $U_{85/86op}$ | ≤ 7,2 V |
| Release voltage ²⁾ | $U_{85/86r}$ | ≥ 1,6 V |
| Coil resistance ¹⁾ | R_{Cu} | 91 Ω ± 0 Ω |
| Parallel resistor | R_P | 560 Ω |
| Total resistance | $R_{85/86}$ | 78 Ω ± 8 Ω |
| Continuous thermal load | P_{θ} | 3,3 W |
| Nom. power consumption | P_N | 1,8 W |
| Release time (typ.) | t_r | 5,5 ms |

¹⁾ At 23 °C coil temperature.

Dimensional drawing

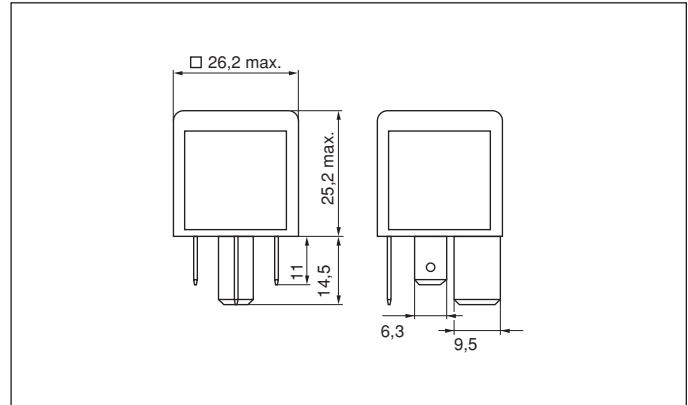

Figure



Connection diagram

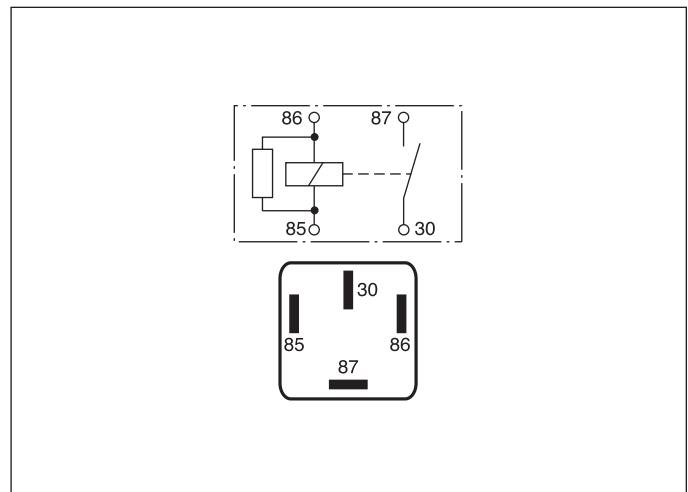

Relays

Mini relays F7

NO relays

BOSCH
Part number Tyco
Volvo-Part number

0 986 332 023
V23134-J0052-X346
9441158

Technical data for contact side

| | | |
|---------------------------------------------|---------------------------|------------------------------|
| Contact material | | Ag |
| Minimum recommended current | $I_{Smin} (U_s = 13,5 V)$ | 1 A |
| Max. switching current ²⁾ - Make | $I_{Smax} on^3) / off$ | 240 A / 70 A |
| Limiting continuous current - Make | $I_{SN} at 23 °C / 85 °C$ | 70 A / 50 A |
| Voltage drop - Make (typ.) | 10 A contact current | 10 mV |
| Increase in coil temperature (typ.) | 10 A contact current | 4 K |
| Mechanical endurance (without load) | | > 1 x 10 ⁷ cycles |
| Electrical endurance ⁴⁾ | | > 2 x 10 ⁵ cycles |

²⁾ The values apply to a resistive or inductive load with suitable spark suppression. ³⁾ This current may flow for a maximum of 3 s for a make / break ratio of 1:10.
⁴⁾ refer to Volvo specification 1282750 issue 05

Technical data for energizing side

| | | |
|-------------------------------|---------------|----------|
| Operate voltage ¹⁾ | $U_{85/86op}$ | ≤ 7,4 V |
| Release voltage ²⁾ | $U_{85/86r}$ | ≥ 1,6 V |
| Coil resistance ¹⁾ | R_{Cu} | 91 Ω±9 Ω |
| Parallel resistor | R_P | 470 Ω |
| Total resistance | $R_{85/86}$ | 76 Ω±8 Ω |
| Nom. power consumption | P_N | 1,9 W |
| Release time (typ.) | t_r | 3,5 ms |

¹⁾ At 23 °C coil temperature.

Dimensional drawing

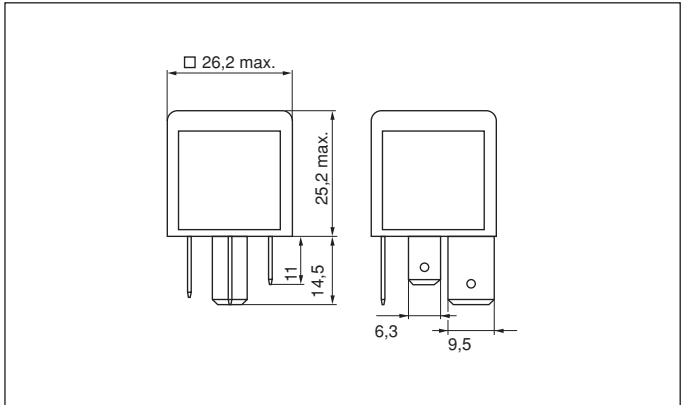

Figure



Connection diagram

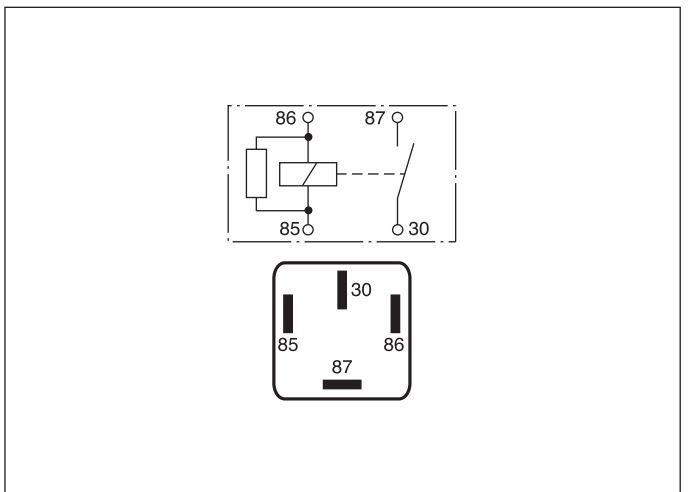

Relays

Mini relays F7

NO relays

BOSCH
Part number Tyco
Opel-Part number

0 986 332 030
V23134-K0052-X220
90 464 760

Technical data for contact side

| | | |
|---------------------------------------------|-----------------------------------|------------------------------|
| Contact material | | Ag, fine-grain |
| Minimum recommended current | I_{Smin} ($U_s = 13,5$ V) | 1 A |
| Max. switching current ²⁾ - Make | I_{Smax} on ³⁾ / off | 120 A / 60 A |
| Limiting continuous current - Make | I_{SN} at 23 °C / 85 °C | 60 A / 40 A |
| Voltage drop - Make (typ.) | 60 A contact current | 60 mV |
| Increase in coil temperature (typ.) | 10 A contact current | 3 K |
| Mechanical endurance (without load) | | > 1 x 10 ⁷ cycles |
| Electrical endurance ⁴⁾ | | > 2 x 10 ⁵ cycles |

²⁾ The values apply to a resistive or inductive load with suitable spark suppression. ³⁾ This current may flow for a maximum of 3 s for a make / break ratio of 1:10.
⁴⁾ for an inductive load 500 μ H 60 A/40 A, on/off current, 0.1 s/1.3 s.

Technical data for energizing side

| | | |
|-------------------------------|---------------|----------------------------|
| Operate voltage ¹⁾ | $U_{85/86op}$ | $\leq 7,4$ V |
| Release voltage ²⁾ | $U_{85/86r}$ | $\geq 1,9$ V |
| Coil resistance ¹⁾ | R_{Cu} | 91 $\Omega \pm 9$ Ω |
| Parallel resistor | R_P | 560 Ω |
| Total resistance | $R_{85/86}$ | 76 $\Omega \pm 8$ Ω |
| Nom. power consumption | P_N | 1,9 W |
| Release time (typ.) | t_r | 3,5 ms |

¹⁾ At 23 °C coil temperature.

Dimensional drawing

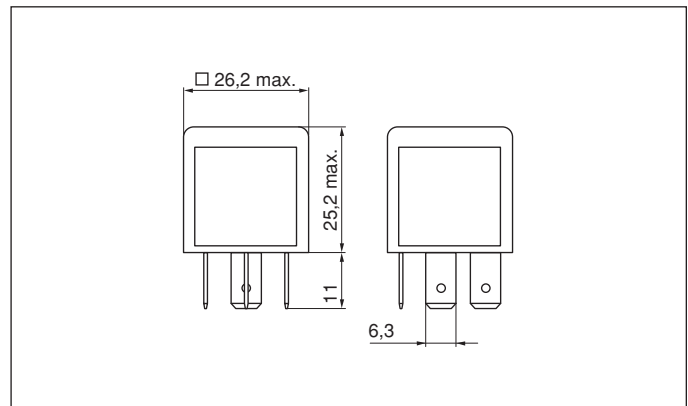

Figure



Connection diagram

