

VIGNAL
LIGHTING GROUP

2017



Camions, Cars et bus - Trucks, Coaches - LKW, Busses

BOBCAT	8
DAF	9
FIAT	14
HEULIEZ	15
IRISBUS	17
IVECO	25
MAN.....	35
MANITOU.....	37
MANITOWOC.....	38
MERCEDES.....	40
NISSAN	41
OPEL	42
PSA.....	43
RENAULT AGRI	44
RENAULT TRUCKS	45
SCANIA	76
UD TRUCKS	78
VOLKSWAGEN.....	79
VOLVO	80

Remorques - Trailers - Anhänger / Auflieger

ASCA	89
BENALU	95
BTK.....	101
CHEREAU	105
ECOVRAC	109
FELDBINDER	111
FRUEHAUF.....	114
LAMBERET	118
LECIÑENA	126
LOUULT	128
MAGYAR.....	132
MAISONNEUVE.....	134
MONTENEGRO.....	136
SAMRO	137
SCHMITZ	143
SOMMER.....	144
TABARRINI	146
TEKNOCAR	149

Produits standard - Standard products - Universalprodukte

Feux arrière - Rear lamps - Heckleuchten

Feux multifonction - Multifunction lamps - Mehrkammerleuchten.....	151
Feux monofonction - Monofunction lamps - Einzelfunktionsleuchten	191
Eclaireurs de plaque - Number plate lamps - Kennzeichenleuchten	192

Feux clignotants - Flasher lamps - Fahrtrichtungsanzeiger

Face avant - Front face - Frontansicht	194
Face latérale - Side face - Seitenansicht	197
Face arrière - Rear face - Heckansicht.....	201

Feux de position - Position lamps - Positionsleuchten

Face avant - Front face - Frontansicht	202
Face latérale - Side face - Seitenansicht	209
Face arrière - Rear face - Heckansicht.....	222

Eclairage - Lighting - Beleuchtung

Feux de conduite - Driving lights - Fahrlicht	228
Feux de travail - Work Lights - Arbeitsscheinwerfer.....	230
Feux auxiliaire - Auxiliary Lights - Arbeitsscheinwerfer.....	242

Produits de sécurité - Safety products - Sicherheitsprodukt

Gyrophares - Rotating beacons - Rundumkennleuchten	244
Feu de pénétration LED - Directional LED light - Bernstein-LED Technologie	252
Alarmes sonores de recul - Back up alarms - Rückfahrhorn.....	253
Systèmes de vision arrière - Rear vision systems - Rückfahrvideo-systeme	254
Signalisation passive - Warnin gproducts - Warnmarkierungen	259
Eclairage intérieur - Dom lamps - Innenraumleuchten	263
Coffres porte extincteur - Extinguisher holder - Feuerlöscher Behälter.....	265

Electricité remorque - Electric products for trailers - Elektrik für Anhänger/Auflieger

Prises et cordons de liaison - Cables and plugs - Anschlusskabel und Steckverbindungen	268
Câblage remorque - Trailers harnesses - Verkabelungsprodukte für Anhänger/Auflieger	272

Recherche produits - Products research - Produktsuche

Par liste de correspondance - By cross list - nach Hersteller-Nr.....	286
Par référence - By part number - nach Artikelnummer	290
Par no. d'homologation - By homologation number - nach Homologationsnummer.....	294
Par photo - By pictures - nach Abbildung	295

Ce catalogue n'est pas contractuel
 This catalogue does not create any contractual tie
 Die Informationen in diesem Katalog sind nicht bindend !
 Wir behalten uns ausdrücklich vor, eventuelle Prospektangaben zu ändern

VIGNAL LIGHTING GROUP



Vignal Lighting Group est spécialisé dans la conception, la fabrication et la commercialisation de produits et systèmes pour l'éclairage et la signalisation de véhicules industriels ou commerciaux dans le respect de la réglementation et de l'environnement.

Vignal Lighting Group is specialized in designing, manufacturing and marketing of lighting and signalling products and systems for industrial and commercial vehicles respecting the directives and the environment.

Unter Berücksichtigung der gesetzlichen Vorschriften und aktuellen Umweltstandards, hat sich die Vignal Lighting Gruppe auf die Konzeption, die Herstellung und den Vertrieb von Produkten/ Systemgruppen für die Beleuchtung von Nutzfahrzeugen spezialisiert.



Une conception globale pour une production locale.

Global design for local production.

Globales Design für die lokale Produktion.

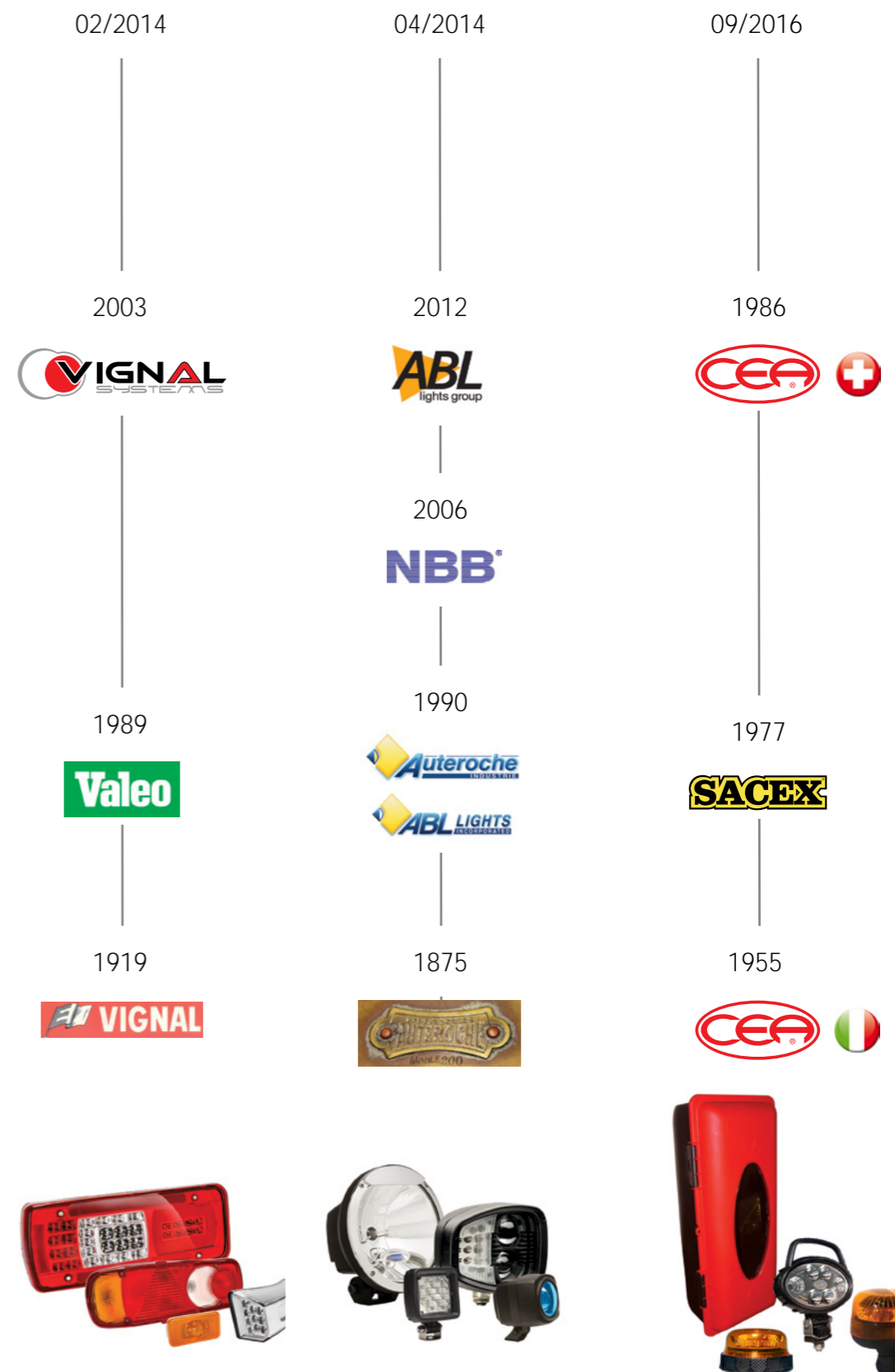

SECTEURS INDUSTRIES BRANCHEN



GUIDE DE LECTURE DES PAGES «PRODUITS D'ORIGINE CONSTRUCTEURS» USER GUIDE PAGES «OE SPARE PARTS PER MANUFACTURER» HINWEISE ZUR KATALOGBENUTZUNG «PRODUKTE NACH FAHRZEUGVERWENDUNG»

Nom du véhicule
Vehicle model
Fahrzeugbezeichnung













Nom du constructeur
Manufacturer
Fahrzeugbezeichnung

IVECO

STRALIS / TRAKKER

LC8

03/2016 ->

<p>New</p>  <p>155450 (OE 5801637199) gauche - left - links</p>	<p>HDSCS latéral Anschlussstecker seitlich</p> 	 <p>155460 (OE 5801637201) droit - right - rechts</p>
 <p>001830</p> <p>Alarme sonore de recul pour feu LCR-droit Right LCR back up alarm Rückfahrwarnhorn für rechte LCR</p>		 <p>155470 (OE 5801637202) droit - right - rechts</p>
<p>New</p>  <p>155480 (OE 5801637182) gauche - left - links</p>	<p>HDSCS arrière Anschlussstecker hinten</p> 	 <p>155490 (OE 5801757328) droit - right - rechts</p>
 <p>001830</p> <p>Alarme sonore de recul pour feu LCR-droit Right LCR back up alarm Rückfahrwarnhorn für rechte LCR</p>		 <p>155500 (OE 5801757326) droit - right - rechts</p>
 <p>055040 gauche - left - links</p>		 <p>055050 droit - right - rechts</p>

03/2016 ->

D13878 p. 276

VIGNAL
LIGHTING GROUP

31

Type de connecteur
Connector type
Anschlussart

Nom produit standard
Reference to standard products
Standardbezeichnung des Produkts

Type de véhicule
Vehicle type
Fahrzeugtyp

Dates d'application
Application dates
Baujahr

Symbole fonctions
Functions symbol
Funktionssymbole

Capotoptère
Reflector
Rückstrahler

Foy de position latéral
Side marker lamp
Seitenmarkierungsleuchte

Eclaireur de plaque
Number plate lamp
Kennzeichenleuchte

Alarme sonore de recul
Back up alarm
Rückfahrwarnhorn



Référence Vignal
Vignal p/n
Art.-Nr. Vignal

Référence constructeur rechange
Manufacturer p/n
Art.-Nr. des Fahrzeugherstellers

152600
(OE 5001858093)

152620
(OE 5001857967)

droit - right - rechts

Spécificité du produit
Product specificity
Besonderheit des Produkts

TL470, MF9000

LC5 p.169



152150
(OE 7164111)
gauche - left - links



052500
(OE 7027476)
gauche - left - links



R12931 - 1200 mm
(OE 7028786)
Raccordement connectique deutsch
Wiring with deutsch connector
Anschlussstecker deutsch



PG
arrière
rear connector
Anschlussstecker hinten



152150
(OE 7164110)
droit - right - rechts



052500
(OE 7027476)
droit - right - rechts



R12934 - 600 mm
(OE 7028787)
Raccordement connectique deutsch
Wiring with deutsch connector
Anschlussstecker deutsch

EPP98 p.193



196010
(OE 7175124) JPT

p.178 LC4

-> 1993



141500
(OE 2922224)
gauche - left - links



040500
(OE 0698603)
gauche - left - links



PE
arrière
rear connector
Anschlussstecker hinten



141500
(OE 2922224)
droit - right - rechts



040500
(OE 0698603)
droit - right - rechts

* Silent blocs non fournis, voir réf. 001706 p.175
*Silent blocs not supplied, see p/n 001706 p.175
* Schwingungsdämpfer Art.-Nr. 001706 nicht im Lieferumfang, Seite p.175

65 - 75 - 85 - 95

p.173 LC7

1993 -> 1995



168100
(OE 1626319/1284213)
gauche - left - links



067500
(OE 1272653)
gauche - left - links



DIN
arrière
rear connector
Anschlussstecker hinten



168390
(OE 1626320/1284214)
droit - right - rechts



067500
(OE 1272653)
droit - right - rechts

CF / XF

CF/XF

LC7 p.173

1995 -> 04/2012



1995 ->2001



167640
(OE 1284211)

168020
(OE 1304789)

gauche - left - links



D12953
(OE 1519358)

Alarme sonore de recul
Back up alarm
Rückfahrwarnhorn



DAF
arrière
rear connector
Anschlussstecker hinten



167630
(OE 1284212)

168010
(OE 1304788)

droit - right - rechts



168890
(OE 1660967)

droit - right - rechts

2001 -> 04/2012



169160
(OE 1625985)

gauche - left - links



D12953
(OE 1519358)

Alarme sonore de recul
Back up alarm
Rückfahrwarnhorn



AMP 1.5
latéral
side connector
Anschlussstecker seitlich



169170
(OE 1625986)

droit - right - rechts



169380
(OE 1660968)

droit - right - rechts



067500
(OE 1272653)

gauche - left - links



067500
(OE 1272653)

droit - right - rechts



Faisceau p. 276
Harness p. 276
Anschlusskabel siehe S. p. 276

LC8 p.160

04/2012 ->



Entraxe : 160 mm
Bolt distance : 160 mm
Schraubenabstand : 160 mm



155100
(OE 1875577)

gauche - left - links



001830
(OE 1973239)

Alarme sonore de recul pour feu LC8 droit
Right LC8 back up alarm
Rückfahrwarnhorn für rechte LC8



HDSCS
latéral
side connector
Anschlussstecker seitlich



155110
(OE 1875576)

droit - right - rechts



155120
(OE 1875578)

droit - right - rechts



155130
(OE 1875580)

gauche - left - links



001830
(OE 1973239)

Alarme sonore de recul pour feu LC8 droit
Right LC8 back up alarm
Rückfahrwarnhorn für rechte LC8



HDSCS
arrière
rear connector
Anschlussstecker hinten



155140
(OE 1875579)

droit - right - rechts



155150
(OE 1875581)

droit - right - rechts



055020
(OE 1914690)

gauche - left - links



055030
(OE 1914691)

droit - right - rechts



D13878 p. 276

ICDL07 p.198

1993 ->



109010
(OE 1814096/1815754)

CF/XF

ICDL10 p.198

01/2013 ->



117000
(OE 1846491)

gauche - left - links



117010
(OE 1846492)

droit - right - rechts

75 - 85 - XF - CF

FPL93 p.215



193020
(OE 1329718)

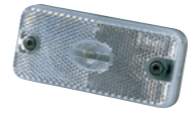

193200
(OE 1653605)



001726
(OE 1608352)



195010
(OE 1403887)

gauche - left - links



195010
(OE 1403887)

droit - right - rechts



119550
(OE 1626101)



001616
(OE 1626102)



102200



clippé - clipped - befestigung



001726
(OE 1608352)

LF

LC5 p.169

2001 ->



152170
(OE 1401713)

gauche - left - links



AMP 1.5
arrière
rear connector
Anschlussstecker hinten



152180
(OE 1401731)



droit - right - rechts



052500
(OE 1451482)

gauche - left - links



052500
(OE 1451482)



droit - right - rechts



Faisceau p. 276
Harness p. 276
Anschlusskabel siehe S. p. 276

LF

FE95 p.208



195010
(OE 1403887)

gauche - left - links



195010
(OE 1403887)

droit - right - rechts



119550
(OE 1626101)



001616
(OE 1626102)



102200



clippé - clipped - befestigung



001726
(OE 1608352)



193020
(OE 1329718)



001726
(OE 1608352)



196010
(OE 0867930)

JPT



Faisceau p. 276
Harness p. 276
Anschlusskabel siehe S. p. 276

DUCATO

LC5 p.169

07/2012 ->

Fixation 4 vis M6 (190x60mm)
Fixing 4 screws M6 (190x60mm)
Befestigung 4 Schrauben M6 (190x60mm)



153270
(OE 1372699080)
gauche - left - links



052500
gauche - left - links



AMP 1.5
arrière
rear connector
Anschlusstecker hinten



153280
(OE 1372698080)
droit - right - rechts



052500
droit - right - rechts

FPL93 p.215



193280
(OE 1356794080 / 71749250)

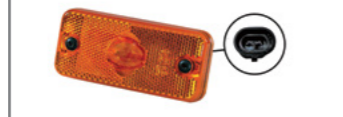

193170
(OE 1305797)



001726



001916



Faisceau p. 276
Harness p. 276
Anschlusskabel siehe S. p. 276

GX

LC6 p.177



166500



PE
arrière
rear connector
Anschlusstecker hinten



066500
cabochon - lens - Lichtscheibe



167150
(OE 2773801/2870801)



067000
(OE 3156201)

LC7 p.173

FE81 p.200



181000
(OE 0190408700)

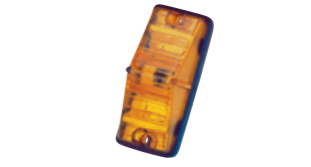

181050
(OE 0190552400)

FE79 p.218



179240
(OE 0190439000)



079040
cabochon - lens - Lichtscheibe

GX

FE85 p.208



185020
(OE 5010217022)



185050
(OE 5010104837)

FE95 p.208



195030
(OE 5010271501)



195060
(OE 5010312524)

FPL93 p.215



193020
(OE 190825600) K



001726

ICDL94 p.199



119550



001616



001626



Faisceau p. 276
Harness p. 276
Anschlusskabel siehe S. p. 276

MAGELYS - ARWAY - CROSSWAY - RECREO

FM97



197080
(OE 5010403075)



197070
(OE 5010403076)

p.199 **ICDL94**



119550
(OE 5001020257)



001616
(OE 5001834568)



001626
(OE 5001837993)

p.208 **FE95**



195030
(OE 5001834505)



195060
(OE 5001834576)

p.211 **SMD98**



198650
(OE 504217797) K

LED



Faisceau p. 276
Harness p. 276
Anschlusskabel siehe S. p. 276

URBAN WAY

ICDL94 p.199



119550
(OE 5001020257)



001616
(OE 5001834568)



001626
(OE 5001837993)

SMD98 p.211

LED



198650
(OE 504217797)



Faisceau p. 276
Harness p. 276
Anschlusskabel siehe S. p. 276

R312 - R332

p.178 **LC4**



142500



040500

p.177 **LC6**



166500



066500

p.173 **LC7**



167150
(OE 5010179915)



067000

p.200 **FE81**



181000
(OE 5000461058)



181050
(OE 5000461059)

p.218 **FE79**



179210
(OE 5000786265)



079010
(OE 5000804703)

cabochon - lens- Lichtscheibe



Faisceau p. 276
Harness p. 276
Anschlusskabel siehe S. p. 276

AGORA - CITELIS

LC7 p.173



167150
(OE 5010179915)

gauche/droit - left/right - links/rechte



067000

C194 p.195



119400
(OE 5001020317)

gauche - left - links



119410
(OE 5001020318)

droit - right - rechts

ICDL94 p.199



119550
(OE 5001020257)



001616
(OE 5001834568)



001626
(OE 5001837993)

FPL93 p.215



193020
(OE 5010306792)

K



001726
(OE 5001847589)



Faisceau p. 276
Harness p. 276
Anschlusskabel siehe S. p. 276

AGORA - CITELIS

p.211 **SMD98**

LED



198650
(OE 504217797)

K

p.208 **FE85**



185020
(OE 5010217022)



185050
(OE 5010104837)

p.208 **FE95**



195030
(OE 5001834505)



195060
(OE 5001834576)

p.192 **BX868**



610091 C5W



Faisceau p. 276
Harness p. 276
Anschlusskabel siehe S. p. 276

TRACER

FPL93 p.215



Faisceau p. 276
Harness p. 276
Anschlusskabel siehe S. p. 276

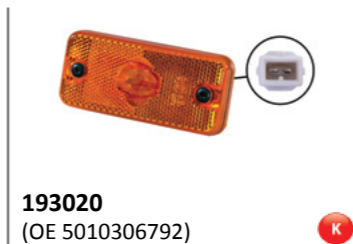

193020
(OE 5010306792)



001726
(OE 5001847589)

FE81 p.200



181000
(OE 5000461058)



181050
(OE 5000461059)

ARES / ILIADE

BD95



195000
(OE 5010286898)



001606
(OE 5001834564)

FE95 p.208



195030
(OE 5001834505)



195060
(OE 5001834576)

ARES / ILIADE

p.199 ICDL94



119550
(OE 5001020257)



001616
(OE 5001834568)



001626
(OE 5001837993)

p.215 FPL93



193020
(OE 5010306792)



001726
(OE 5001847589)



Faisceau p. 276
Harness p. 276
Anschlusskabel siehe S. p. 276

ARES

FM97



197080
(OE 5010403075)



197070
(OE 5010403076)

ILIADE

C195



119500
(OE 5010286903)

gauche - left - links



119510
(OE 5010286904)

droit - right - rechts

FR1

FM91



191170 - P21W
(OE 5010197259)

Feu de recul
Reverse lamp
Rückfahrleuchte



191140 - P21W
(OE 5010197261)

Feu de position
Position lamp
Schlussleuchte



191120 - P21W
(OE 5010197262)

Feu stop
Stop lamp
Bremsleuchte



191150 - P21W
(OE 50101972564)

Feu clignotant arrière
Reverse flasher lamp
Hintere Blinkleuchte



191100 - P21W
(OE 5010177690)

Plafonnier
Ceiling light
Deckenleuchte



191110 - P21W
(OE 5010197260)

Feu de brouillard
Fog lamp
Nebelschlussleuchte

FE85

p.208



185010
(OE 5010086923)



185030
(OE 5010086924)

EUROSTAR - EUROTECH - EUROTRAKKER

p. 173

LC7

1996 -> 2002



168610
(OE 99463244)

gauche - left - links



IVECO
arrière
rear connector
Anschlussstecker hinten



168600
(OE 99463242)

droit - right - rechts



067500
(OE 93161844)

gauche - left - links



067500
(OE 93161844)

droit - right - rechts

p. 215

FPL93



193020
(OE 500308514)



001726
(OE 1608352)

MASSIF 4 X 4

p. 169

LC5

2002 ->



152180
(OE 791123)

gauche - left - links



AMP 1.5
arrière
rear connector
Anschlussstecker hinten



152180
(OE 791123)

droit - right - rechts



052500
(OE A610067-002)

gauche - left - links



052500
(OE A610067-002)

droit - right - rechts



Faisceau p. 276
Harness p. 276
Anschlusskabel siehe S. p. 276

EUROCARGO

STRALIS - TRAKKER - ASTRA HD7/HD8

LC7 p.173

LC7 p.173

1996 ->

2002 ->



168590
(OE 99463243)
gauche - left - links



IVECO
arrière
rear connector
Anschlussstecker hinten



168600
(OE 99463242)
droit - right - rechts



168610
(OE 99463244)
gauche - left - links



IVECO
arrière
rear connector
Anschlussstecker hinten



168600
(OE 99463242)
droit - right - rechts



168610
(OE 99463244)
gauche - left - links



D12953



168480
(OE R504083205)
droit - right - rechts



067500
(OE 93161844)
gauche - left - links



067500
(OE 93161844)
droit - right - rechts



067500
(OE 93161844)
gauche - left - links



067500
(OE 93161844)
droit - right - rechts

C105 p.194

C199 p.194

06/2008 -> 09/2012

2002 -> 05/2007

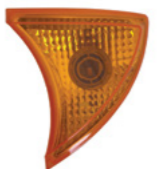

110520
(OE 42555042)
gauche - left - links

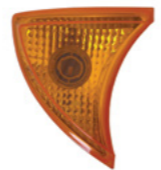

110530
(OE 42555041)
droit - right - rechts



119920
(OE 41221041)
gauche - left - links



119930
(OE 41221040)
droit - right - rechts

09/2012 ->

C105 p.194
05/2007 -> 09/2012



110550
(OE 5801572024)
gauche - left - links



110560
(OE 5801572018)
droit - right - rechts

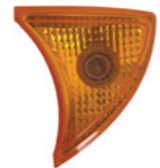

110520
(OE 42555042)
gauche - left - links

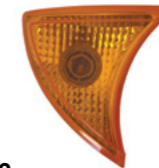

110530
(OE 42555041)
droit - right - rechts

STRALIS - TRAKKER - ASTRA HD7/HD8

C105 p.194

09/2012 ->



110550
(OE 5801572024)
gauche - left - links



110560
(OE 5801572018)
droit - right - rechts

FPL93 p.215



193170
(OE 41200664) **K**
superseal



001916
superseal

EUROCARGO - STRALIS - TRAKKER

LC7 p.173

09/2011 -> EURO 6



169390
(OE 5801363428) **K FPL**
gauche - left - links



DIN
arrière
rear connector
Anschlusstecker hinten



169410
(OE 5801363431) **K FPL**
droit - right - rechts



169400
(OE 5801363430) **K FPL EPP**
gauche - left - links



169420
(OE 5801363432) **K FPL ASR**
droit - right - rechts



067500
(OE 93161844) **K**
gauche - left - links



067500
(OE 93161844) **K**
droit - right - rechts

EUROCARGO - STRALIS - TRAKKER

LC5 p.169

06/2011 -> EURO 6



AMP 1.5
arrière
rear connector
Anschlusstecker hinten



153220
(OE 5801426889) **K**
gauche - left - links



153210
(OE 5801426894) **K**
droit - right - rechts



153200
(OE 5801426912) **K EPP**
gauche - left - links



153230
(OE 5801426917) **K ASR**
droit - right - rechts



153240
(OE 5801426975) **K**
gauche - left - links



153250
(OE 5801426977) **K**
droit - right - rechts

153260
(OE 5801426979) **K ASR**
droit - right - rechts



052500
(OE 42566495) **K**
gauche - left - links



052500
(OE 42535711) **K**
droit - right - rechts



Faisceau p. 276
Harness p. 276
Anschlusskabel siehe S. p. 276

FPL93 p.215



193020
(OE 500308514) **K**



001726
(OE 1608352)

SMD98 p.211



198760
(OE 5801631615) **K**

LED

-> 10/2014

STRALIS / TRAKKER

LC11

p. 30

LED

03/2016 ->



New



160150
(OE 5802062689)
gauche - left - links



HDSCS
latéral
side connector
Anschlusstecker seitlich



160100
(OE 5802000573)
droit - right - rechts



160080
(OE 5802000568)
gauche - left - links



160090
(OE 5802000767)
droit - right - rechts

03/2016 ->



New



160110
(OE 5802000570)
gauche - left - links



HDSCS
arrière
rear connector
Anschlusstecker hinten



160130
(OE 5802000770)
droit - right - rechts



160140
(OE 5802055273)
gauche - left - links



160120
(OE 5802000772)
droit - right - rechts

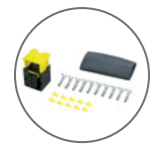

D13878 p. 276



060000
gauche - left - links



060010
droit - right - rechts

STRALIS / TRAKKER

p. 160

LC8

03/2016 ->



New



155450
(OE 5801637199)
gauche - left - links



HDSCS
latéral
side connector
Anschlusstecker seitlich



155460
(OE 5801637201)
droit - right - rechts



001830
Alarme sonore de recul pour feu LC8 droit
Right LC8 back up alarm
Rückfahrtsignalhorn für rechte LC8



155470
(OE 5801637202)
droit - right - rechts

New



155480
(OE 5801637182)
gauche - left - links



HDSCS
arrière
rear connector
Anschlusstecker hinten



155490
(OE 5801757328)
droit - right - rechts



155540
(OE 5802055272)
gauche - left - links



155500
(OE 5801757326)
droit - right - rechts



055040
gauche - left - links



055050
droit - right - rechts

DESIGN EFFET FUMÉ - MÉTALLISÉ
SMOKED EFFECT & METALLIZED DESIGN

03/2016 ->



D13878 p. 276

DAILY

725 p.180



725040

gauche - left - links



725010

droit - right - rechts

LC7 p.173

1996 -> 1999

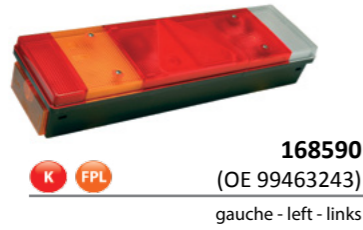

168590

(OE 99463243)
gauche - left - links



IVECO
arrière
rear connector
Anschlussstecker hinten



168600

(OE 99463242)
droit - right - rechts

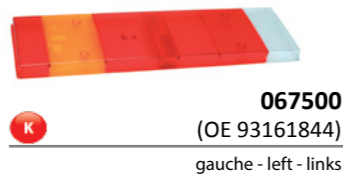

067500

(OE 93161844)
gauche - left - links



067500

(OE 93161844)
droit - right - rechts

FPL93 p.215

1996 ->



Faisceau p. 276
Harness p. 276
Anschlusskabel siehe S. p. 276



193020

(OE 500308514)



001726

(OE 1608352)



193290

(OE 504097923)

FE94 p.223

1999 ->



198060

(OE 500341613)



001586

DAILY

725 p.180

1999 -> 06/2006



D11482
(OE 500356783)

gauche - left - links



AMP 1.5
arrière
rear connector
Anschlussstecker hinten



D11481
(OE 500356782)

droit - right - rechts



D11480

gauche - left - links



D11479

droit - right - rechts

06/2006 ->



D12334
(OE 69500032)

gauche - left - links



AMP 1.5
arrière
rear connector
Anschlussstecker hinten



D12335
(OE 69500026)

droit - right - rechts



D12336
(OE 42555132)

gauche - left - links



D12337
(OE 42555131)

droit - right - rechts

725 V

06/2006 ->



D12338
(OE 69500591)

3.5T

D12340
(OE 69500047)

5T
gauche - left - links



D12339
(OE 69500590)

3.5T

D12341
(OE 69500044)

5T
droit - right - rechts

SEDDON EUROMOVER

LC7 p.173

2000 ->



168590
(OE 99463243)
gauche - left - links



IVECO
arrière
rear connector
Anschlussstecker hinten



168600
(OE 99463242)
droit - right - rechts



067500
(OE 93161844)
gauche - left - links



067500
(OE 93161844)
droit - right - rechts

ICDL94 p.199



119550
(OE 97163920)



001616
(OE 5001834568)



Faisceau p. 276
Harness p. 276
Anschlusskabel siehe S. p. 276

TGE

LC8 p.160

04/2017 ->

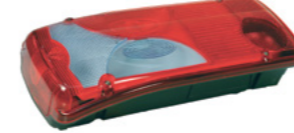

155550
(OE 7CE 945 095)
gauche - left - links



AMP 1.5
arrière
rear connector
Anschlussstecker hinten



155560
(OE 7CE 945 096)
droit - right - rechts

TGA - TGL - TGM - TGX

LC8 p.160

2005 ->



156200
(OE 8125225-6544)
gauche - left - links

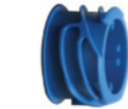

AMP 1.5
latéral
side connector
Anschlussstecker seitlich



156210
(OE 8125225-6545)
droit - right - rechts



001830
90 db

001872
55-90 db



156220
(OE 8125225-6547)
droit - right - rechts

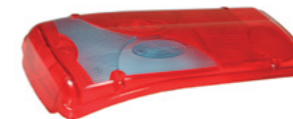

056500
(OE 8125229-6059)
gauche - left - links



056510
(OE 8125229-6060)
droit - right - rechts

NEOBUS

LC6 p.177



166700
(OE 8125225-6469)
gauche - left - links



PE
arrière
rear connector
Anschlussstecker hinten



166700
(OE 8125225-6470)
droit - right - rechts



066500
gauche - left - links



066500
droit - right - rechts



Faisceau p. 276
Harness p. 276
Anschlusskabel siehe S. p. 276

L - M - F

LC7

p.173

1990 -> 2004



168090
(OE 8125225-6033)
gauche - left - links



168090
(OE 8125225-6464)
droit - right - rechts



168100
(OE 8125225-6034)
gauche - left - links



168490
(OE 8125225-6528)
droit - right - rechts



067500
(OE 8125229-6051)
gauche - left - links



067500
(OE 8125229-6051)
droit - right - rechts

TGA

LC7

p.173

1999 -> 2005



169180
(OE 8125225-6526)
gauche - left - links

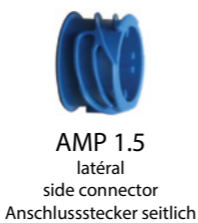

169170
(OE 8125225-6523)
droit - right - rechts



169160
(OE 8125225-6524)
gauche - left - links



169190
(OE 8125225-6530)
droit - right - rechts



067500
(OE 8125229-6051)
gauche - left - links



067500
(OE 8125229-6051)
droit - right - rechts



Faisceau p. 276
Harness p. 276
Anschlusskabel siehe S. p. 276

MANISCOPIC

p.169

LC5

2001 ->



152180
(OE 223767)
gauche - left - links



152180
(OE 223766)
droit - right - rechts



052500
gauche - left - links



052500
droit - right - rechts

MSI

p.183

BBS516

1999 ->



500930
(OE 163782)
gauche - left - links



500940
(OE 163783)
droit - right - rechts



610091
(OE 227330)

p.192

BX868

p.228

3800 LED

LED



D14380
(OE 959694)
gauche - left - links



D14381
(OE 959695)
droit - right - rechts



Faisceau p. 276
Harness p. 276
Anschlusskabel siehe S. p. 276

GROVE

LC8

p. 160



156860
(OE 03137250)
gauche - left - links



AMP 1.5
arrière
rear connector
Anschlussstecker hinten



156870
(OE 03137251)
droit - right - rechts



001830
(OE 03137254)
ASR



056540
gauche - left - links



056550
droit - right - rechts

LC5

p. 169



152170
(OE 03320939)
gauche - left - links



AMP 1.5
arrière
rear connector
Anschlussstecker hinten



152180
(OE 03320938)
droit - right - rechts



052500
gauche - left - links



052500
droit - right - rechts



Faisceau p. 276
Harness p. 276
Anschlusskabel siehe S. p. 276



001746
Câble pour connection EPP séparé
Wiring for number plate lamp
Anschlusskabel für Kennzeichenleuchte

GROVE

p. 211

SMD98

LED



198660
(OE 03138527)
LED-24V



198520
(OE 03320937)
4 x LED-24V



D10493 - 500 mm
(OE 03329572)
4 x LED-24V



198640
(OE 03329492)
LED-24V



Faisceau p. 276
Harness p. 276
Anschlusskabel siehe S. p. 276

SPRINTER

LC8 p.160

06/2006 ->



156340
(OE A9068200464)
gauche - left - links



AMP 1.5
arrière
rear connector
Anschlusstecker hinten



156350
(OE A9068201764)
droit - right - rechts



056540
(OE A0008262056)
gauche - left - links



056550
(OE A0008262156)
droit - right - rechts

ACTROS

EPP96 p.193

06/2012 -> Lowliner



196170
(OE A9495400104)

CABSTAR - ATLEON

LC5 p.169



152170
(OE 26555-9X126)
gauche - left - links



AMP 1.5
arrière
rear connector
Anschlusstecker hinten



152180
(OE 26555-9X125)
droit - right - rechts



153120
(OE 26555-9X128)
droit - right - rechts



052500
(OE 26554-9X126)
gauche - left - links



052500
(OE 26554-9X126)
droit - right - rechts

ICDL94 p.199



119550
(OE 26164-9X402)



001616
(OE 26244-9X400)



Faisceau p. 276
Harness p. 276
Anschlusskabel siehe S. p. 276



Faisceau p. 276
Harness p. 276
Anschlusskabel siehe S. p. 276

MOVANO - VIVARO

JUMPY - JUMPER - EXPERT - BOXER

LC5 p.169

LC5 p.169

04/2010 ->

07/2012 ->



152180
(OE 4421265)

gauche - left - links



AMP 1.5
arrière
rear connector
Anschlusstecker hinten



152180
(OE 4421266)

droit - right - rechts



052500

gauche - left - links



052500

droit - right - rechts

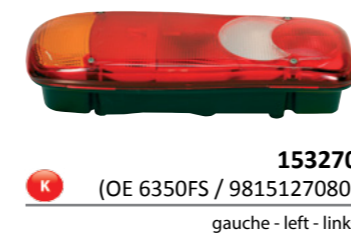

153270
(OE 6350FS / 9815127080)

gauche - left - links



AMP 1.5
arrière
rear connector
Anschlusstecker hinten



153280
(OE 6351FS / 9815126980)

droit - right - rechts



Fixation 4 vis M6 (190x60mm)
Fixing 4 screws M6 (190x60mm)
Befestigung 4 Schrauben M6 (190x60mm)



052500

gauche - left - links



052500

droit - right - rechts

EPP98 p.193

04/2010 ->



196010
(OE 4421269)

JPT



Faisceau p. 276
Harness p. 276
Anschlusskabel siehe S. p. 276

RENAULT AGRI

LA25 p.187



125100
(OE 7700694212)
gauche - left - links



PE
arrière
rear connector
Anschlusstecker hinten



125200
(OE 7700694211)
droit - right - rechts



025100
gauche - left - links



025200
droit - right - rechts

EPP96 p.193



196020
(OE 7700027564)

EURO 6 - T / K / C / D

p.158 **LC9 LED**

New



158030
(OE 7425982261)
gauche - left - links



AMP 1.5
latéral
side connector
Anschlusstecker seitlich



158050
droit - right - rechts

LED
En option
Optional



158040
(OE 7425982262)
droit - right - rechts



058000
(OE 7422800391)
gauche - left - links



058000
(OE 7422800391)
droit - right - rechts

p.259 **TRI**



D14564
(OE 7420856783)



Faisceau p. 276
Harness p. 276
Anschlusskabel siehe S. p. 276

EURO 6 - T / K / C --> 520 CH

LC9 p.159

EURO6

11/2013 ->



159010
(OE 7420802348)
gauche - left - links



AMP 1.5
latéral
side connector
Anschlussstecker seitlich



159020
(OE 7420802350)
droit - right - rechts



D12953



159030
(OE 7420802353)
droit - right - rechts



Faisceau p. 276
Harness p. 276
Anschlusskabel siehe S. p. 276



059000
(OE 7420802418)
gauche - left - links



059000
(OE 7420802418)
droit - right - rechts

FE09

EURO6

11/2013 ->



115020
(OE 7482346591)
gauche - left - links



115020
(OE 7482346591)
droit - right - rechts



115000
(OE 7482252506)
gauche - left - links



115010
(OE 7482367030)
droit - right - rechts

EURO 6 - T / K / C --> 520 CH

FE09

EURO6

11/2013 ->



115040
(OE 7482252291)



115030
(OE 7482255014)

SL08

EURO6

11/2013 ->



113020
(OE 7482266219) 10W
Lampe de portière
Door lamp
Türleuchte



113030
(OE 7482285707) 5W
Feu d'embarquement
Step lamp
Einstiegsbeleuchtung

SMD00

LED
EURO6

11/2013 ->



198620
(OE 7482392733)
Cuve blanche - cabochon PMMA
White body - PMMA lens
Weißes Gehäuse - PMMA Lichtscheibe



198740
(OE 7482586940)
Cuve ambre - cabochon PC haute température
Amber body - PC lens high temperature
Oranges Gehäuse - PC Lichtscheibe hoch temperatur beständig

SHD 1200

EURO6

07/2014 ->



D14161
(OE 7484185589) LED 12/24-100V



D14169
câble adaptateur DT-AMP
adapter cable DT-AMP
adapterkabel DT-AMP

MAGNUM

LC6

p.177

1991 -> 12/1998



12/1998 -> 09/2004

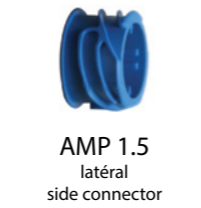

Faisceau p. 276
Harness p. 276
Anschlusskabel siehe S. p. 276



LC7

p.173

1990 -> 1994



1994 -> 12/1998



* Cales non fournies, voir réf. 001656 p. 175

* Bricks not supplied, see p/n 001656 p. 175

* Distanzstücke Art.-Nr. 001656 nicht im Lieferumfang, s Seite 175

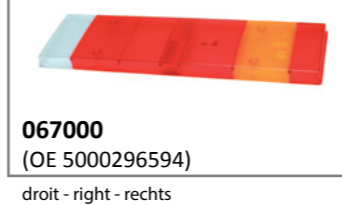
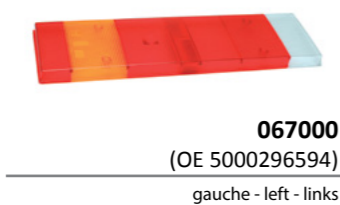

MAGNUM

p.173

LC7

12/1998 -> 09/2004



09/2004 -> 01/2006



Entraxe : 160 mm
Bolt distance : 160 mm
Schraubenabstand : 160 mm

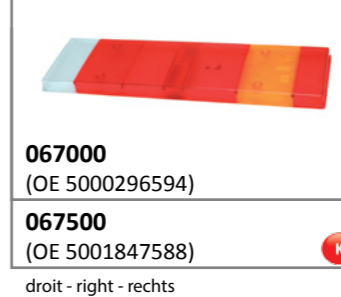
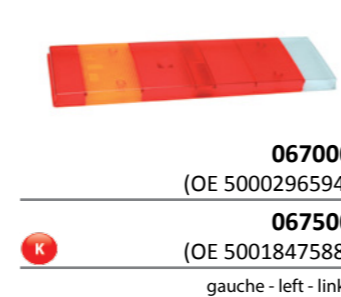

Faisceau p. 276
Harness p. 276
Anschlusskabel siehe S. p. 276

MAGNUM

LC9 p.159

01/2006 ->



159010
(OE 7420802348)
gauche - left - links



AMP 1.5
latéral
side connector
Anschlussstecker seitlich



159020
(OE 7420802350)
droit - right - rechts



D12953
ASR



159030
(OE 7420802353)
droit - right - rechts



Faisceau p. 276
Harness p. 276
Anschlusskabel siehe S. p. 276



059000
(OE 7420802418)
gauche - left - links



059000
(OE 7420802418)
droit - right - rechts

C184 p.195

1991 -> 2003

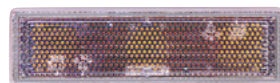

118440
(OE 5010306711)
gauche - left - links

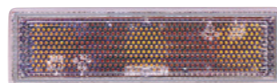

118440
(OE 5010306711)
droit - right - rechts

FE85 p.208

1991 ->



185020
(OE 5010217022)
gauche - left - links



185020
(OE 5010217022)
droit - right - rechts

1991 -> 12/1998



185040
(OE 5010217023)
5W
gauche - left - links



185040
(OE 5010217023)
5W
droit - right - rechts

MAGNUM

p.198 **FE85**

12/1998 ->



185160
(OE 5010271807)
21W
gauche - left - links



185160
(OE 5010271807)
21W
droit - right - rechts



104570
(OE 7421430181/7482562006)



104450
(OE 7421137718)

p.202 **FE04**

LED

06/2008 ->



193020
(OE 5010306792 / 7484538758) **K**



001726
(OE 5001847589)

p.215 **FPL93**

1994 ->



102200
(OE 5001862030) **K**
Clippé - clipped - clip-befestigung



001726
(OE 5001847589)

p.205 **FE02**

2003 ->



D13019 *
(OE 7421396991)



D13020 *
(OE 7421396993)

p.240 **SH3**

10/2009 ->



* Lampe fournie
* Bulb included
* Inklusiv Glühlampen

PREMIUM / KERAX

LC6 p.177

Premium
1995 -> 12/1998



Kerax
1995 -> 09/1998



166100 *
(OE 5000296591)

gauche - left - links



PE
arrière
rear connector
Anschlussstecker hinten



166000 *
(OE 5000296591)

droit - right - rechts

Premium
12/1998 -> 09/2004



169060
(OE 5001847582)

gauche - left - links



AMP 1.5
latéral
side connector
Anschlussstecker seitlich



169070
(OE 5001847583)

droit - right - rechts

* Silent blocs non fournis,
voir réf. 001706 p. 175

* Silent blocs not supplied,
see p/n 001706 p. 175

* Schwingungsdämpfer Art.-Nr.
001706 nicht im Lieferumfang, s.
Seite p. 175



066000
(OE 5000296593)

gauche - left - links



066000
(OE 5000296593)

droit - right - rechts

LC5 p.169

Premium
06/2001 -> 09/2004



152020 *
(OE 5001846847)

gauche - left - links



AMP 1.5
arrière
rear connector
Anschlussstecker hinten



152500 **
(OE 5001858092)

droit - right - rechts

152510 **
(OE 5001857964)

gauche - left - links

* pas de fonction recul
* no reverse function
* ohne Rückfahrchein werfer

** pas de fonction brouillard
** no fog function
** ohne Nebelschlussleuchte



052000
(OE 5010392231)

gauche - left - links



052000
(OE 5010392231)

droit - right - rechts

Faisceau p. 276
Harness p. 276
Anschlusskabel siehe S. p. 276

PREMIUM / KERAX

p.173 **LC7**

Premium
1995 -> 1999
Kerax
1995 -> 09/1998



168220
(OE 5001831194)

gauche - left - links



PE
arrière
rear connector
Anschlussstecker hinten



168260
(OE 5001832999)

droit - right - rechts

168260
(OE 5001832999)

gauche - left - links

168140
(OE 5001835853)

droit - right - rechts



067000
(OE 5000296594)

gauche - left - links



067000
(OE 5000296594)

droit - right - rechts

Premium
1999 -> 09/2004



169020
(OE 5001847586)

gauche - left - links



AMP 1.5
latéral
side connector
Anschlussstecker seitlich



169030
(OE 5001847587)

droit - right - rechts



067000
(OE 5000296594)

gauche - left - links



067000
(OE 5000296594)

droit - right - rechts

Premium
1999 -> 09/2004
Kerax
09/1998 -> 09/2004



169000
(OE 5001847584)

gauche - left - links



169010
(OE 5001847585)

droit - right - rechts



067500
(OE 5001847588)

gauche - left - links



067500
(OE 5001847588)

droit - right - rechts



Faisceau p. 276
Harness p. 276
Anschlusskabel siehe S. p. 276

PREMIUM / KERAX / EURO 6 - C --> 320 CH

LC7 p.173

Premium
09/2004 -> 01/2006
Kerax
09/2004 -> 09/2006



Entraxe : 160 mm
Bolt distance : 160 mm
Schraubenabstand : 160 mm

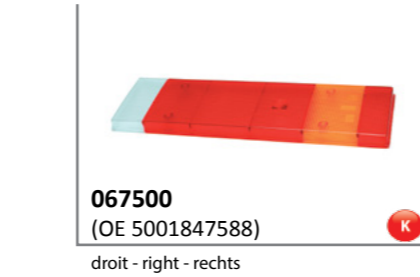
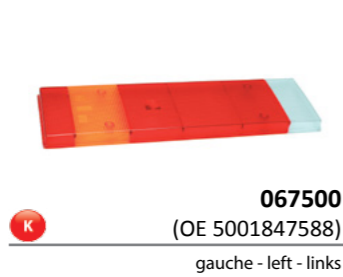
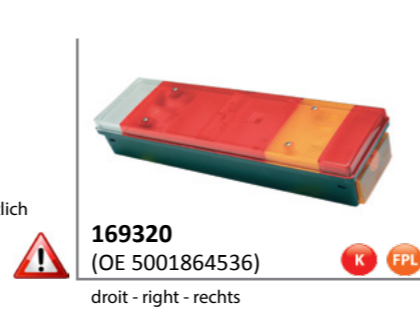

LC9 p.159

EURO6

01/2006 ->



Faisceau p. 276
Harness p. 276
Anschlusskabel siehe S. p. 276

PREMIUM / KERAX / EURO 6 - C --> 320 CH

p.195 **C194**

Premium
1995 -> 06/2006
Kerax 1995 ->



p.208 **FE95**

EURO6
1995 ->

p.199 **ICDL94**

EURO6
Premium 12/1998 ->
Kerax 1999 ->



p.205 **FE02**

EURO6
2003 ->



Faisceau p. 276
Harness p. 276
Anschlusskabel siehe S. p. 276

PREMIUM / KERAX / EURO 6 - C --> 320 CH

FPL93 p.215

1995 ->



193020
(OE 5010306792) K

2003 ->



193200
(OE 5001862030) K
Vissé - Screwed - Geschraubt



Faisceau p. 276
Harness p. 276
Anschlusskabel siehe S. p. 276



001726
(OE 5001847589)

SMD98 p.211

LED
EURO6

09/2007 ->



198650
(OE 7421106206) K
Feu d'identification Viscope
Viscope identification lamp
Markierungsleuchte Viscope

SH3 p.240

EURO6

10/2009 ->



D13019 *
(OE 7421396991)



D13020 *
(OE 7421396993)

* Lampe fournie
* Bulb included
* Inklusiv Glühlampen

MIDLINER

LC4 p.178



141500
(OE 5000808172) K EPP
gauche - left - links



PE
arrière
rear connector
Anschlussstecker hinten



141500
(OE 5000808172) K EPP
droit - right - rechts



040500
(OE 5000808166) K
gauche - left - links



040500
(OE 5000808166) K
droit - right - rechts

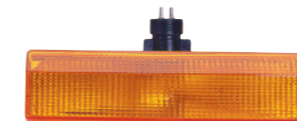

10850603
(OE 5000462758)
gauche - left - links

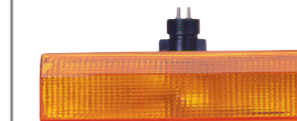

10850603
(OE 5000462758)
droit - right - rechts

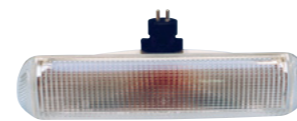

10850605
(OE 5010271775)
gauche - left - links

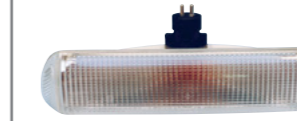

10850605
(OE 5010271775)
droit - right - rechts



186030
(OE 5000463046)
gauche - left - links



186040
(OE 5000463047)
droit - right - rechts

1085 p.196

1986 -> 1996

1996 -> 1999

FE86 p.208

1986 -> 1999

MIDLUM / EURO 6 - D --> 18 T

LC5 p.169

1999 -> 09/2005



152020 *
(OE 5001846847)

152060 **
(OE 5001846849)

gauche - left - links



AMP 1.5
arrière
rear connector
Anschlussstecker hinten



152030 **
(OE 5001846848)

152070 *
(OE 5001846850)

droit - right - rechts

09/2005 ->



EURO6



152190
(OE 7420862038)

gauche - left - links



152200
(OE 7420862041)

droit - right - rechts



052000
(OE 5010392231)

gauche - left - links



052000
(OE 5010392231)

droit - right - rechts



1999 -> 09/2005



152000 *
(OE 5001846843)

152040 **
(OE 5001846845)

gauche - left - links



152010 **
(OE 5001846844)

152050 *
(OE 5001846846)

droit - right - rechts



052500
(OE 5001847153)

gauche - left - links



052500
(OE 5001847153)

droit - right - rechts



Faisceau p. 276
Harness p. 276
Anschlusskabel siehe S. p. 276

MIDLUM / EURO 6 - D --> 18 T

p.169 LC5

EURO6

09/2005 ->



152880
(OE 7420862032)

gauche - left - links



AMP 1.5
arrière
rear connector
Anschlussstecker hinten



152880
(OE 7420862035)

droit - right - rechts



052500
(OE 5001847153)

gauche - left - links



052500
(OE 5001847153)

droit - right - rechts



169000
(OE 5001847584)

gauche - left - links



AMP 1.5
latéral
side connector
Anschlussstecker seitlich



169010
(OE 5001847585)

droit - right - rechts



067500
(OE 5001847588)

gauche - left - links



067500
(OE 5001847588)

droit - right - rechts



Faisceau p. 276
Harness p. 276
Anschlusskabel siehe S. p. 276

p.193 EPP96

1999 -> 2003



196020
(OE 7700353021)



196010
(OE 5010293829) JPT

p.193 EPP98

EURO6

2003 ->

MIDLUM / EURO 6 - D --> 18 T

FM91

08/2008 ->



191170
(OE 7421268609)

C194

p. 195

1999 ->



119400
(OE 5001834560)
gauche - left - links



119410
(OE 5001834559)
droit - right - rechts

ICDL94

p. 199

EURO6

> 1999



119450
(OE 5001834565) 5W

1999 ->



119470
(OE 5001847597) 21W



001616
(OE 5001834568)

FE95

p. 208

EURO6

1999 ->



195010
(OE 5001834561)
gauche - left - links



195010
(OE 5001834561)
droit - right - rechts

MIDLUM / EURO 6 - D --> 18 T

p. 205

FE02

EURO6

2003 ->



102200
(OE 5001862030) K
Clippé - clipped - rechts



001726
(OE 5001847589)

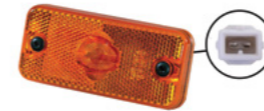

193020
(OE 5010306792 / 7484538758) K



193280
(OE 5001862030) K



001726
(OE 5001847589)

FPL93

p. 215

1999 ->

MAXITY / EURO 6 - D --> 7,5 T

p. 169

LC5

EURO6

2009 ->



152170
(OE 7485118470) K EPP
gauche - left - links



AMP 1.5
arrière
rear connector
Anschlussstecker hinten



152180
(OE 5001870556) K
droit - right - rechts



052500
(OE 5001847153) K
gauche - left - links



052500
(OE 5001847153) K
droit - right - rechts



Faisceau p. 276
Harness p. 276
Anschlusskabel siehe S. p. 276

MASCOTT

LC4

p. 178

1998 -> 07/2001



141500
(OE 5000808172)
gauche - left - links



040500
(OE 5000808166)
gauche - left - links



141500
(OE 5000808172)
droit - right - rechts



040500
(OE 5000808166)
droit - right - rechts

LC5

p. 169

07/2001 -> 04/2006



152020 *
(OE 5001846847)

152510 **
(OE 5001857964)

gauche - left - links



152500 **
(OE 5001858092)

152520 *
(OE 5001857965)

droit - right - rechts

* pas de fonction recul
* no reverse function
* ohne Rückfahrchein werfer

** pas de fonction brouillard
** no fog function
** ohne Nebelschlussleuchte

04/2006 ->



152170
gauche - left - links



052000
(OE 5010392231)

052500
(OE 5001847153)

gauche - left - links



152180
droit - right - rechts



052000
(OE 5010392231)

052500
(OE 5001847153)

droit - right - rechts

Faisceau p. 276
Harness p. 276
Anschlusskabel siehe S. p. 276

MASCOTT

p. 169

LC5

07/2001 -> 04/2006

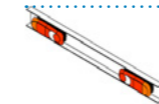

152000 *
(OE 5001846843)

152610 **
(OE 5001857966)

gauche - left - links



152600 **
(OE 5001858093)

152620 *
(OE 5001857967)

droit - right - rechts

* pas de fonction recul
* no reverse function
* ohne Rückfahrchein werfer

** pas de fonction brouillard
** no fog function
** ohne Nebelschlussleuchte

04/2006 ->



152880
(OE 7420862032)

gauche - left - links



152880
(OE 7420862035)

droit - right - rechts



052500
(OE 5001847153)

gauche - left - links



052500
(OE 5001847153)

droit - right - rechts

FM97

1998 ->



197050
(OE 7700377095)



197040
(OE 7700377094)

p. 193

EPP98

1998 ->



196010
(OE 5010293829)

JPT



Faisceau p. 276
Harness p. 276
Anschlusskabel siehe S. p. 276

MASCOTT

ICDL94 p.199

1998 ->



SMD98 p.211

LED

1998 ->



CA p.259

1998 -> 04/2006

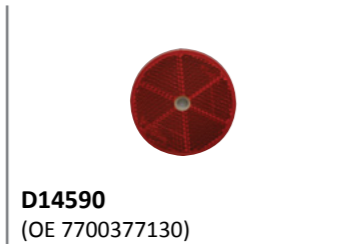

04/2006 ->

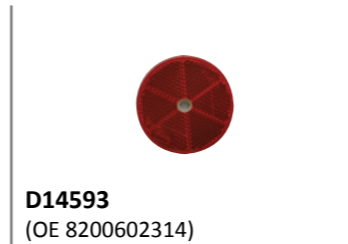

TRAFIC

LC5 p.169

10/2014 ->

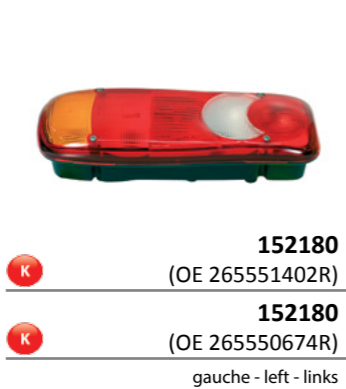

Faisceau p. 276
Harness p. 276
Anschlusskabel siehe S. p. 276

MASTER

p.169 **LC5**

04/2010 ->

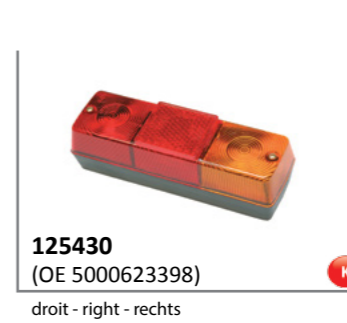

p.187 **LA25**

p.193 **EPP96**

-> 04/2010



p.193 **EPP98**

04/2010 ->



Faisceau p. 276
Harness p. 276
Anschlusskabel siehe S. p. 276

MASTER

SMD98 p.211

LED

04/2010 ->



K

GAMME B

LC4 p.178



EPP

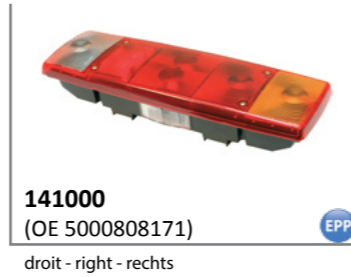

EPP



LA25 p.187

-> 06/1993

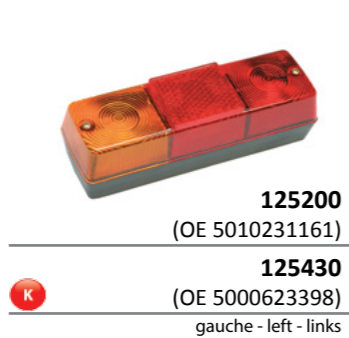

K

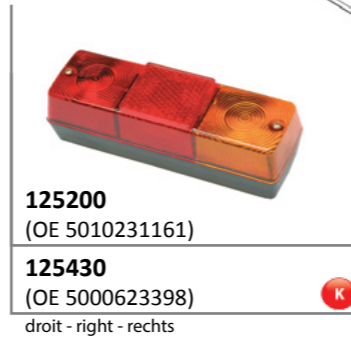

K



K



K

GAMME B

p.208 **FE85**



p.215 **FPL93**



K



GAMME C

p.186 **LA35**

-> 1986



EPP



EPP



GAMME C

LC4 p.178

-> 1986



141500
(OE 5000808172)

gauche - left - links



040500
(OE 5000808166)

gauche - left - links



PE
arrière
rear connector
Anschlusstecker hinten



141500
(OE 5000808172)

droit - right - rechts



040500
(OE 5000808166)

droit - right - rechts

C166 p.190

-> 1986



116600
(OE 0027567009)



PF
arrière
rear connector
Anschlusstecker hinten



016600
(OE 003603705)

cabochon - lens - lichtsheibe

FE81 p.200

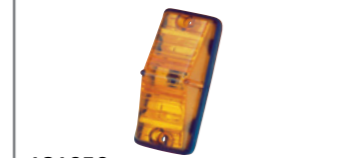

181050
(OE 5000461059)



181000
(OE 5000461058)

GAMME C

p.217 FE87



178340
(OE 5010040505)



087040
(OE 5000808095)

cabochon - lens - lichtsheibe



188310
(OE 5000623050)



088010
(OE 5000296718)

cabochon - lens - lichtsheibe

GAMME G

p.178 LC4

-> 1986



141000
(OE 5000808171)

141500
(OE 5000808172)

gauche - left - links



PE
arrière
rear connector
Anschlusstecker hinten



141000
(OE 5000808171)

141500
(OE 5000808172)

droit - right - rechts



040000
(OE 5000807304)

040500
(OE 5000808166)

gauche - left - links



040000
(OE 5000807304)

040500
(OE 5000808166)

droit - right - rechts

GAMME G

LC6 p.177

1986 ->



166000
(OE 5000296591)
gauche - left - links



PE
arrière
rear connector
Anschlusstecker hinten



166000
(OE 5000296591)
droit - right - rechts



066000
(OE 5000296593)
gauche - left - links



066000
(OE 5000296593)
droit - right - rechts

LC7 p.173

1986 ->



167001
(OE 5000296592)
gauche - left - links



PE
arrière
rear connector
Anschlusstecker hinten



167001
(OE 5000296592)
droit - right - rechts



067000
(OE 5000296594)
gauche - left - links



067000
(OE 5000296594)
droit - right - rechts

GAMME J

p.186 LA35



135200
(OE 5000589493)
gauche - left - links



PF
arrière
rear connector
Anschlusstecker hinten

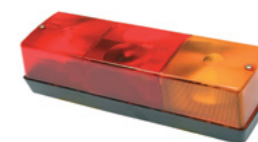

135200
(OE 5000589493)
droit - right - rechts



035000
(OE 5000803784)
gauche - left - links



035000
(OE 5000803784)
droit - right - rechts

p.190 C166



116600
(OE 0027567009)



PF
arrière
rear connector
Anschlusstecker hinten



016600
(OE 003603705)
cabochon - lens - lichtscheibe

p.200 FE81



181050
(OE 5000461059)



181000
(OE 5000461058)

GAMME J

FE87 p.217



FPL93 p.215



GAMME R

LC4 p.178

-> 1994

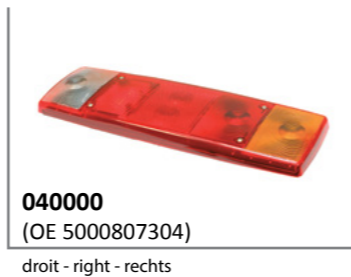
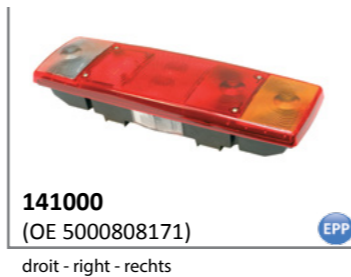

GAMME R

p.173 **LC7**

1994 ->

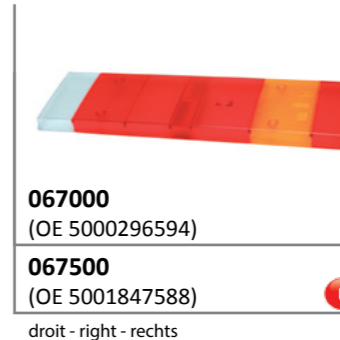
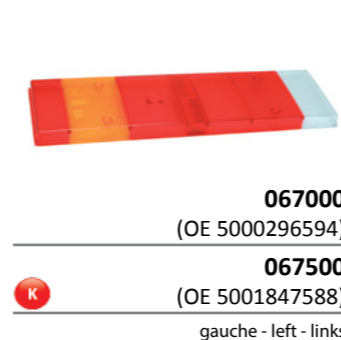

* Cales non fournies, voir réf. 001656 p. 175

* Bracks not supplied, see p/n 001656 p. 175

* Distanzstücke Art.-Nr. 001656 nicht im Lieferumfang, s Seite p. 175

p.195 **C177**

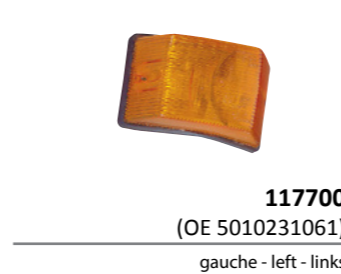

p.205 **FG82**



GAMME R

FPL93 p.215



Faisceau p. 276
Harness p. 276
Anschlusskabel siehe S. p. 276



193020
(OE 5010306792 / 7484538758) **K**



001726
(OE 5001847589)

GAMME S

LA25 p.187

-> 06/1993

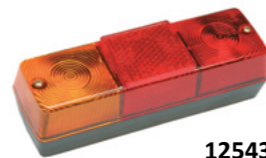

125430
(OE 5000623398) **K**
gauche - left - links



PE
arrière
rear connector
Anschlusstecker hinten

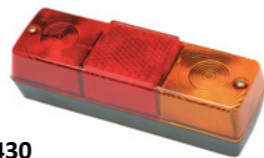

125430
(OE 500062398) **K**
droit - right - rechts



025210
(OE 5000810542) **K**
gauche - left - links



025210
(OE 5000810542) **K**
droit - right - rechts

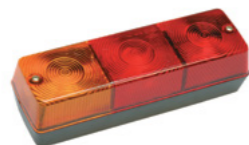

125200
(OE 5010231161)
gauche - left - links



PE
arrière
rear connector
Anschlusstecker hinten

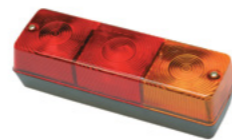

125200
(OE 5010231161)
droit - right - rechts



025200
(OE 5001825075)
gauche - left - links



025200
(OE 5001825075)
droit - right - rechts

GAMME S

p.178 **LC4**

-> 06/1993



141000
(OE 5000808171) **EPP**
gauche - left - links



PE
arrière
rear connector
Anschlusstecker hinten



141000
(OE 5000808171) **EPP**
droit - right - rechts



040000
(OE 5000807304)
gauche - left - links



040000
(OE 5000807304)
droit - right - rechts

p.217 **FE87**



178340
(OE 5010040505)



087040
(OE 5000808095)
cabochon - lens - lichtscheibe



188310
(OE 5000623050)



088010
(OE 5000296718)
cabochon - lens - lichtscheibe

SERIE 3

LC7 p.173

1990 -> 1998



168350
(OE 1365963)

168370
(OE 1365965)

gauche - left - links



067500
(OE 1350343)

gauche - left - links



168360
(OE 1365964)

168380
(OE 1365966)

droit - right - rechts



067500
(OE 1350343)

droit - right - rechts

SERIE P&R

LC8 p.160

01/2007 ->



156770
(OE 1756754/2021579/2129985)

gauche - left - links



AMP 1.5
latéral
side connector
Anschlusstecker seitlich



156780
(OE 1756751/2021575/2129987)

droit - right - rechts



155020
(OE 2021578/2129986)

gauche - left - links



156790
(OE 1791369/2021576/2129988)

droit - right - rechts



056540
(OE 1784669/2129992)

gauche - left - links



056550
(OE 1784670/2129991)

droit - right - rechts



001830



Faisceau p. 276
Harness p. 276
Anschlusskabel siehe S. p. 276

SCANIA

LC8 p.160

08/2013 ->



155080
(OE 2160128)

gauche - left - links



AMP 1.5
arrière
rear connector
Anschlusstecker hinten



155520
(OE 2340796)

droit - right - rechts



155090
(OE 2160127)

droit - right - rechts



056540
(OE 1784669/2129992)

gauche - left - links



056550
(OE 1784670/2129991)

droit - right - rechts



001830



D14564
(OE 2020496)



D13019
H3/70W-24V

TRI p. 259

SH3 p. 77



Faisceau p. 276
Harness p. 276
Anschlusskabel siehe S. p. 276

QUON - CONDOR

LC5 p. 169



05/2015 ->



153860
(OE 261319Z01B)

153880 *
(OE 261319Z01D)

gauche - left - links



052500
(OE 265509Z00A)

gauche - left - links



AMP 1.5
arrière
rear connector
Anschlusstecker hinten



153870
(OE 261319Z01C)

153890 *
(OE 261319Z01E)

droit - right - rechts



052500
(OE 265509Z00A)

droit - right - rechts

* pas de fonction brouillard
* no fog function
* ohne Nebelschlussleuchte

EPP98 p. 193

05/2015 ->



196010
(OE 265109Z00A) JPT

ICDL15 **New**

05/2015 ->



120000
(OE 84655961) PY21W - 24V



Faisceau p. 276
Harness p. 276
Anschlusskabel siehe S. p. 276

CRAFTER

LC8 p. 160

06/2006 ->
05/2017



156340
(OE 2E0945095A)

gauche - left - links



056540
(OE 2E0945111A)

gauche - left - links



AMP 1.5
arrière
rear connector
Anschlusstecker hinten



156350
(OE 2E0945096A)

droit - right - rechts



056550
(OE 2E0945112A)

droit - right - rechts



155570
(OE 7CA 945 095)

gauche - left - links



055020

gauche - left - links



AMP 1.5
arrière
rear connector
Anschlusstecker hinten



155580
(OE 7CA 945 096)

droit - right - rechts



055030

droit - right - rechts

LC8 p. 160

06/2017 ->



Faisceau p. 276
Harness p. 276
Anschlusskabel siehe S. p. 276

FH

LC9 LED p.158

LED

12/2012 ->



158030
(OE 82849894 / 84195505 / 84441766)

gauche - left - links



AMP 1.5
latéral
side connector
Anschlusstecker seitlich



158050
(OE 82849923 / 84195521 / 84441768)

droit - right - rechts



158040
(OE 82849925 / 84195519 / 84441767)

droit - right - rechts



058000
(OE 82849905)

droit - right - rechts



058000
(OE 82849905)

gauche - left - links



Faisceau p. 276
Harness p. 276
Anschlusskabel siehe S. p. 276

SRD08 p.197

LED

09/2012 ->



111000
LED 24V (OE 82151157)

gauche - left - links



111010
LED 24V (OE 82151205)

droit - right - rechts



111020
LED 24V (OE 21346521)

gauche - left - links



111030
LED 24V (OE 21346522)

droit - right - rechts

FH

SRD07 p.197

LED

FH 08/2008 -> 09/2012



107000
LED 24V (OE 82114506 / 82355678)

gauche - left - links



107010
LED 24V (OE 82114500 / 82355684)

droit - right - rechts



107040
(OE 82114504 / 21448885)

gauche - left - links



107050
(OE 82114502 / 21478751)

droit - right - rechts



FE08 H2

LED

09/2012 ->



112000
LED 24V (OE 82278938)

112030
LED 24V (OE 21319995)

gauche - left - links



112010
LED 24V (OE 82278930)

112020
LED 24V (OE 21319996)

droit - right - rechts

ID08

LED

09/2012 ->



114000
LED 24V (OE 21214534)

114010
LED 24V (OE 82150539)

114020
LED 24V (OE 21214524)

FH

FE08 H1

LED

09/2012 ->



116010
LED 24V (OE 82349220) ○

116030
LED 24V (OE 21368782) ●
gauche - left - links



116040
LED 24V (OE 82348508) ○

116050
LED 24V (OE 21368779) ●

116060
LED 24V (OE 21368781) ●



116000
LED 24V (OE 82349221) ○

116020
LED 24V (OE 21368783) ●
droit - right - rechts

FE07

LED

08/2008 ->



207000
LED 24V (OE 82116545)



207020
LED 24V (OE 21087347)



207010
LED 24V (OE 21087346)

SL08

09/2012 ->



113000
5W (OE 82202076)

Lampe de portière
Door lamp
Türleuchte

FH - FM

p. 240

SH3



D12111
LED 24V (OE 20872890) H3/70W-24V



D12112
LED 24V (OE 20882716) H3/35W-24V



D14161
LED 12/100V (OE 84185589)

05/2014 -> 12/2015
LED



D14169

câble adaptateur DT-AMP
adapter cable DT-AMP
adapterkabel DT-AMP

FH - FM - FL

p. 211

SMD00



198620
LED 24V (OE 82392733) K

Cuve blanche - cabochon PMMA
White body - PMMA lens
Weißes Gehäuse - PMMA Lichtscheibe



198740
LED 24V (OE 84044658) K

Cuve ambre - cabochon PC haute température
Amber body - PC lens high temperature
Oranges Gehäuse - PC Lichtscheibe hoch temperatur beständig



001766
LED 24V (OE 85105029)

-> 2001
adaptateur - adaptor - adapterkabel

FM

LC10 LED p.157

LED

09/2013 ->

159500
(OE 82483074 / 84441759)
gauche - left - links

AMP 1.5
latéral
side connector
Anschlusstecker seitlich

159530
(OE 21735299 / 84441937)
droit - right - rechts

159520
(OE 21735301 / 84441936)
gauche - left - links

159510
(OE 82483073 / 84441760)
droit - right - rechts



Faisceau p. 276
Harness p. 276
Anschlusskabel siehe S. p. 276

059500
(OE 84122332)
gauche - left - links

059500
(OE 84122332)
droit - right - rechts

SRD07 p.197

LED

09/2010 -> 10/2013

107000
LED 24V (OE 82114506 / 82355678)
gauche - left - links

+

=

107010
(OE 82114500 / 82355684) LED 24V
droit - right - rechts

107040
(OE 82114504 / 21448885)
gauche - left - links

107050
(OE 82114502 / 21478751)
droit - right - rechts

11/2013 ->



107500
LED 24V (OE 82467736)
gauche - left - links

107510
(OE 82467737) LED 24V
droit - right - rechts

FM

FE07

LED

08/2008 ->

207000
(OE 82116545) LED 24V

207010
(OE 21087346) LED 24V

207020
(OE 21087347) LED 24V

FE

p.159

LC9

2006 ->



159010
(OE 20769775)
gauche - left - links

AMP 1.5
latéral
side connector
Anschlusstecker seitlich

159020
(OE 20769776)
droit - right - rechts

D12953

159030
(OE 20769777)
droit - right - rechts

059000
(OE 20802418)
gauche - left - links

059000
(OE 20802418)
droit - right - rechts



Faisceau p. 276
Harness p. 276
Anschlusskabel siehe S. p. 276

FL - FE

LC5 p. 169

2006 -> 



EPP

152190
(OE 20769783)

gauche - left - links



AMP 1.5
arrière
rear connector
Anschlussstecker hinten



152200
(OE 20769784)

droit - right - rechts



K

152880
(OE 20769781)

gauche - left - links



152880
(OE 20769782)

droit - right - rechts



Faisceau p. 276
Harness p. 276
Anschlusskabel siehe S. p. 276



K

052000
(OE 20537280)

gauche - left - links

052500
(OE 20745060)

gauche - left - links



052000
(OE 20537280)

droit - right - rechts

052500
(OE 20745060)

droit - right - rechts

ICDL94 p. 199



119550
(OE 21341202)



001616
(OE 20745227)

FE95 p. 208



195010
(OE 20745225)

gauche - left - links



195010
(OE 20745225)

droit - right - rechts

FL - FE

p. 240 SH3



D13019*
(OE 21396991)

* Lampe fournie
* Bulb included
* Inklusiv Glühlampen

FL

p. 205 FE02



102200
(OE 20717520)

clippé - clipped - befestigung



001726
(OE 20745066)

2006 ->



193020
(OE 20734485 / 84538758)

p. 215 FPL93



001726
(OE 20745066)

p. 193 EPP98



196010
(OE 20721495)

JPT



Faisceau p. 276
Harness p. 276
Anschlusskabel siehe S. p. 276

BUS -COACH

SMD98

p. 211

LED

-> 2003



198650

(OE 20480486)

2xLED 24V



SMD98

p. 222

LED

-> 2003



198640

(OE 70364301)

LED 24V



CONSTRUCTION

SMD98

p. 211

LED



198520

(OE 11170068)

4xLED 24V



TRI

p. 259



D14564

(OE 82466757)



Faisceau p. 276
Harness p. 276
Anschlusskabel siehe S. p. 276

New

p. 153

LC12T



161000

gauche - left - links



AMP 1.5
arrière
rear connector
Anschlussstecker hinten



161010

droit - right - rechts

LED

p. 166

LC8T



156040

gauche - left - links



AMP 1.5
arrière
rear connector
Anschlussstecker hinten



156050

droit - right - rechts



156060

gauche - left - links



056700

gauche - left - links



056710

droit - right - rechts

p. 171

LC5TDX



153660

gauche - left - links



AMP 1.5
arrière
rear connector
Anschlussstecker hinten



153670

droit - right - rechts



053700

gauche - left - links



053710

droit - right - rechts



Faisceau p. 276
Harness p. 276
Anschlusskabel siehe S. p. 276

LC5 p. 169



152200

gauche - left - links



AMP 1.5
arrière
rear connector
Anschlussstecker hinten



152200

droit - right - rechts



152190

gauche - left - links



052000

gauche - left - links



052000

droit - right - rechts

LC4 p. 178



141000

gauche - left - links



PE
arrière
rear connector
Anschlussstecker hinten



141000

droit - right - rechts



040000

gauche - left - links



040000

droit - right - rechts



Faisceau p. 276
Harness p. 276
Anschlusskabel siehe S. p. 276

p. 193 EPP96



196020

R10W



D10502

410 mm

p. 202 FE04

LED



104310

LED-24V
5000 mm



D10132

200 mm

p. 203 SMD04

LED



104140

LED-24V
1500 mm



104260

LED-24V
1500 mm

p. 203 SMD98

LED



D11399

LED-24V
1500 mm



D10494

2 x LED-24V
500 mm



D10497

1500 mm



001776

1500 mm



Faisceau p. 276
Harness p. 276
Anschlusskabel siehe S. p. 276

DXLC8 p.219



D13034

gauche - left - links



D13035

droit - right - rechts

SL 850 p.231

LED



D14288

Feu homologué recul - Homologated reverse lamp - Genehmigt Rückfahrleuchte

FCA

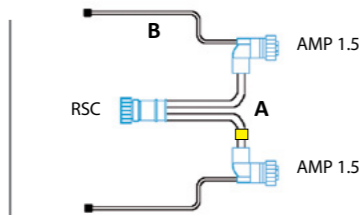

A11832 A: 2 m / B: 16 m **16V**

Faisceau pour feux arrière avec câbles plats et surmoulages coudés
Rear lamp cable with flat cables and 90° overmoulding
Leitungssatz für Heckleuchten mit gewinkeltem Stecker und Flachkabel
= gauche - left - links

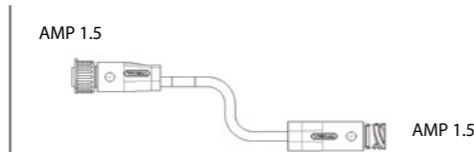

D12450 2000 mm

Rallonge pour feux arrière
Rear lamp extension lead
Verlängerung für Heckleuchte

PRL



A11814 5,5 m **16V**

A11818 16 m **16V**

A11838 3 m **16V**

Câble d'alimentation principale RSC simple
Single RSC main supply cable
Haupt-Verlängerungskabel für RSC

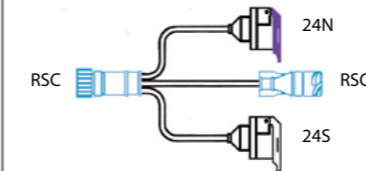

A11844 500 mm **16V**

Rallonge avec adaptateur de prises 24N/24S
Extension lead with 24N/24S plugs adapters
Verlängerung mit 24N/24S Adapter

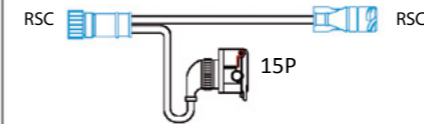

A11841 500 mm **16V**

Rallonge avec adaptateur de prise 15 pôles
Extension lead with 15P plug adapter
Verlängerung mit Adapter für 15 poligen Stecker

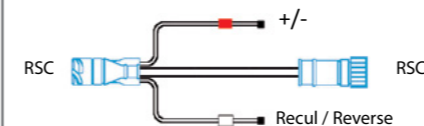

A11105 500 mm **16V**

Interface prolongateur avec câbles plats masse / alimentation et recul
Extension lead with flat cables ground / supply and reverse
Verlängerung mit Flachbandkabel Masse / Rückfahrcheinwerfer

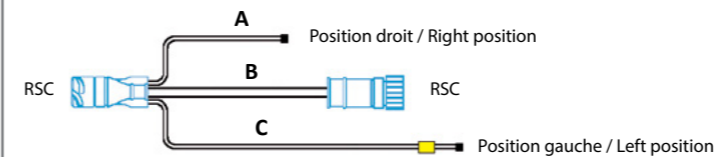

A11848 A: 300 mm / B: 500 mm / C: 3 m **16V**

Interface prolongateur avec câbles plats pour feux de position
Extension lead with flat cables position lamps
Verlängerung mit Flachbandkabel Positionsleuchte

MDJ

A 175020

B A11961 500 mm 16V

C A11962 500 mm 16V

RSC femelle / female / Weiblich
RSC mâle / male / Männlich

Interface module de jonction pour dérivations multiples
Junction box with multiple entries
Verteilerbox für mehrere Anschlüsse

ADP

24N
24S

RSC

A11670 2000 mm 16V

Faisceau prises 24N / 24S
Cable with plugs 24N / 24S
Anschlusskabel mit Steckdosen 24N / 24S

15P

RSC

A11702 2000 mm 16V

Faisceau prises 15P
Cable with plugs 15P
Anschlusskabel mit Steckdosen 15P

24S
15P
24N

RSC

A13816 300 mm 16V

Faisceau prises 15P / 24N / 24S
Cable with plugs 15P / 24N / 24S
Anschlusskabel mit Steckdosen 15P / 24N / 24S

FCA

Deutsch

Click-in

A12486 1500 mm

Câble rond avec connecteurs autoproforant et deutsch pour feu de travail
Round cable with click-in and deutsch connectors for work lamp
Rundes Kabel mit click-in und Deutsch Stecker für den Arbeitsscheinwerfers

New

161000

gauche - left - links

AMP 1.5
arrière
rear connector
Anschlusstecker hinten

161010

droit - right - rechts

p. 153

LC12T

LED

156040

gauche - left - links

AMP 1.5
arrière
rear connector
Anschlusstecker hinten

156050

droit - right - rechts

p. 166

LC8T

001830

ASR

056700

gauche - left - links

056710

droit - right - rechts

p. 193

EPP96

D10502 410 mm

D11888 1000 mm



Faisceau p. 276
Harness p. 276
Anschlusskabel siehe S. p. 276

EPP96 LED

p. 192

LED



D13874

LED-24V
2000 mm

SMD98

p. 203

LED



D10500

2 x LED-24V
500 mm

D11399

1500 mm



001716



D10494

LED-24V
500 mm

D10497

1500 mm

SMD04

p. 210

LED



104250

LED-24V
500 mm

104260

1500 mm



104640

LED-24V
300 mm

104650

1000 mm

bride rallongée - extended bracket - Montagewinkel verlängerter

DXLC8

p. 219



D13034

gauche - left - links



D13035

droit - right - rechts



D10503

660 mm

D11796

1500 mm



610080

LED



D13875

LED-12/24V
1000 mm

Multi-Frequency



D13810

12/24V
97 db
1500 mm



175020

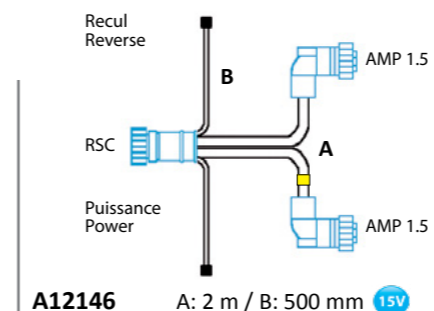

A12146

A: 2 m / B: 500 mm

Faisceau pour feux arrière avec câbles plats puissance et recul, surmoulages coulés
Rear lamp cable with power and reverse flat cables and 90° overmoulding
Leitungssatz für Heckleuchten mit gewinkeltem Stecker und Flachkabel für Spannungsversorgung und Rückfahrcheinwerfer
 = gauche - left - links

p. 221

DX

p. 253

ASR

p. 275

MDJ

FCA



Faisceau p. 276
Harness p. 276
Anschlusskabel siehe S. p. 276

FCA

New

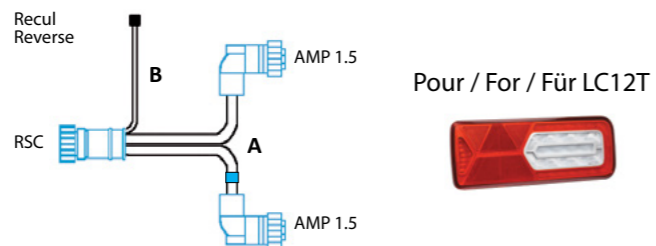

A14109 A: 2 m / B: 500 mm 16V

Faisceau pour feu arrière LC12T avec câble plat recul, surmoulages coudés
LC12T Rear lamp cable with reverse flat cable and 90° overmoulding
Leitungssatz für LC12T Heckleuchten mit gewinkeltem Stecker und Flachkabel für Rückfahrcheinwerfer
= gauche - left - links



D13726

Capot de protection pour connectique coudée feu arrière
Protective cover for rear lamp 90° connector
Schutzkappe für Heckleuchte mit gewinkeltem Stecker

PRL

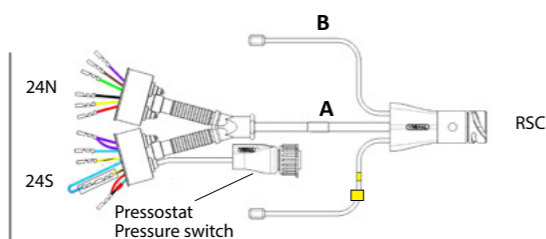

A12720 A: 13 m / B: 3 m 15V

Câble d'alimentation principale RSC avec câbles plats, connecteur pressostat et socle pour 24N, 24S
RSC main supply cable with flat cables, pressure switch connector and 24N, 24S sockets
RSC Hauptkabel mit Flachbandkabeln, Anschluss für Druckschalter und Steckdosen für 24N, 24S
= gauche - left - links

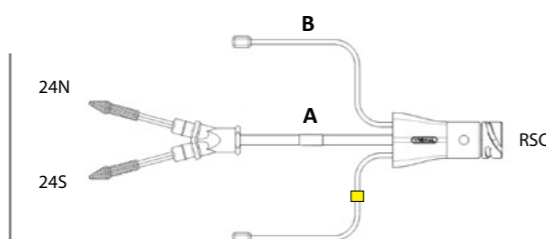

A12052 A: 18 m / B: 3 m 15V

Câble d'alimentation principale RSC avec câbles plats, dérivation protégée pour 24N, 24S
RSC main supply cable with flat cables, protected entries 24N, 24S
RSC Hauptkabel mit Flachbandkabeln, geschützter Anschluss für 24N, 24S
= gauche - left - links

PRL

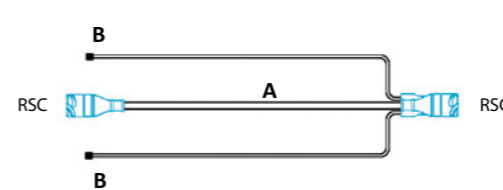

A14090 A: 10 m / B: 13 m 16V

A10911 A: 13 m / B: 16 m 16V

A14127 A: 18 m / B: 20 m 16V

Câble d'alimentation principale RSC avec câbles plats
Single RSC main supply cable with flat cables
Haupt-Verlängerungskabel für RSC mit Flachkabel

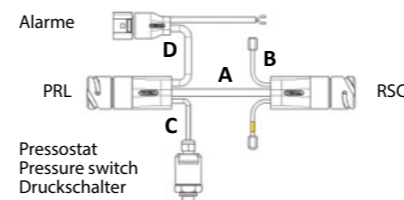

A14101 A: 10 m / B: 13 m / C: 1,5 m / D: 500 mm 16V

A14102 A: 13 m / B: 16 m / C: 1,5 m / D: 500 mm 16V

A14103 A: 18 m / B: 20 m / C: 1,5 m / D: 500 mm 16V

Câble d'alimentation principale RSC simple + raccordement pressostat et alarme
Single RSC main supply cable + pressure switch and alarm connections
Haupt-Verlängerungskabel für RSC + Anschluss für Druckschalter und Signalhorn

FCA

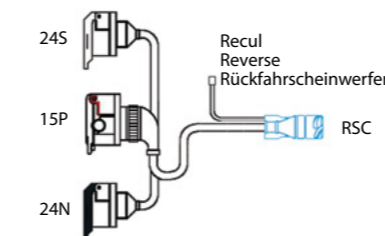

A14106 300 mm 16V

Faisceau prises 15P / 24N / 24S
Cable with plugs 15P / 24N / 24S
Anschlusskabel mit Steckdosen 15P / 24N / 24S

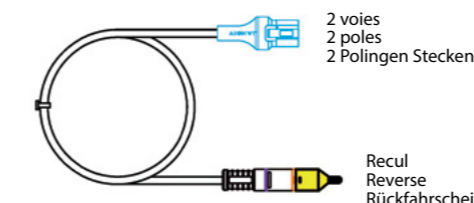

A11440 6000 mm

Câble rond ADR avec connecteur 2 voies stop et connecteur haldex
ADR Round cable with 2 poles stop connector and haldex connector
Rundes ADR-Kabel mit 2 polig stecker für Bremslicht und Haldex Stecker

Pour / For / Für LC8



KIT

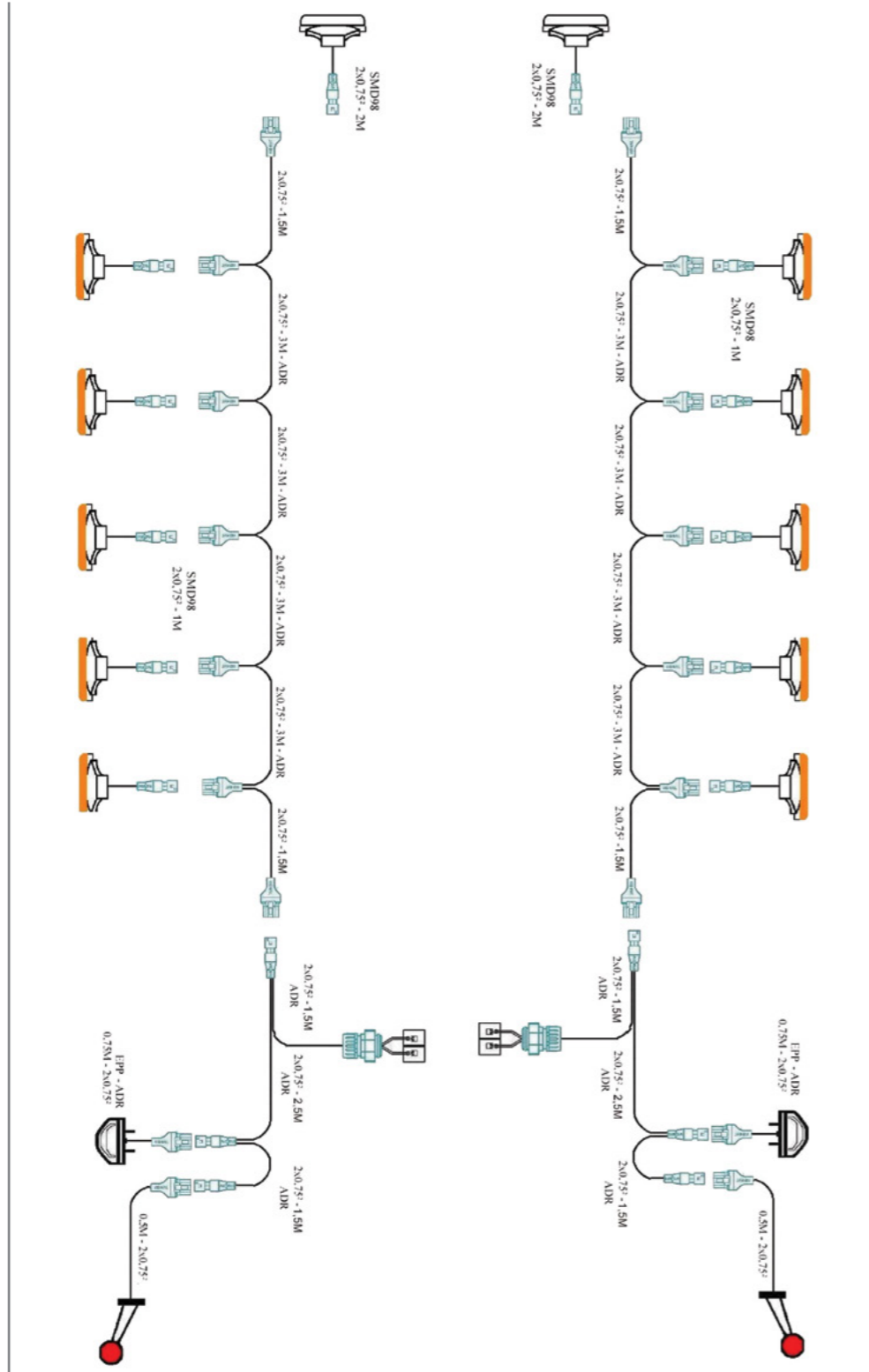

D13295

Kit : 2 feux sur antennes DX câbles 2V 500mm, 2 Eclaireurs de plaque EPP96 câble 2V 750 mm, 8 feux de position latéraux LED SMD98 bride coudée câble 2V 1000 mm, 2 feux de position avant LED SMD98 bride coudée câble 2V 1000 mm.
Kit : 2 end outline marker lamps DX 2V cable 500 mm, 2 license plate lamps EPP96 2V cable 750 mm, 8 LED side marker lamps SMD98 90° bracket 2V cable 1000 mm, 2 LED front marker lamp SMD98 90° bracket 2V cable 1000 mm.
Kit : 2 Spurhalteleuchten DX mit 500mm Kabel und 2V Anschluss, 2 Kennzeichenleuchten mit 750mm Kabel und 2V Anschluss, 8 LED Seitenmarkierungsleuchten SMD98 mit 90° Montagewinkel, 1000mm Kabel und 2V Anschluss, 2 vordere LED Positionslampen SMD98 mit 90° Montagewinkel, 1000mm Kabel und 2V Anschluss

New



161000
gauche - left - links



AMP 1.5
arrière
rear connector
Anschlussstecker hinten



161010
droit - right - rechts

p. 153

LC12T

LED



156040
gauche - left - links



AMP 1.5
arrière
rear connector
Anschlussstecker hinten



156050
droit - right - rechts

p. 166

LC8T



056700
gauche - left - links



056710
droit - right - rechts



153660
gauche - left - links



AMP 1.5
arrière
rear connector
Anschlussstecker hinten



153670
droit - right - rechts

p. 171

LC5TDX



153000
gauche - left - links



153010
droit - right - rechts



053700
gauche - left - links



053710
droit - right - rechts



Faisceau p. 276
Harness p. 276
Anschlusskabel siehe S. p. 276

LC5 p. 169



152180

gauche - left - links



AMP 1.5
arrière
rear connector
Anschlussstecker hinten



152180

droit - right - rechts

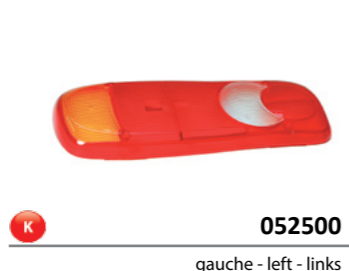

052500

gauche - left - links



052500

droit - right - rechts

EPP96 p. 193



196020

R10W

EPP96 LED p. 192

LED



D13610

LED-24V
1500 mm



Faisceau p. 276
Harness p. 276
Anschlusskabel siehe S. p. 276

p. 203 SMD04

LED



104130

LED-24V
500 mm

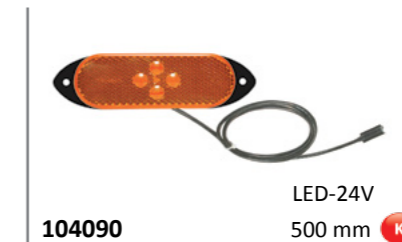

104090

LED-24V
500 mm



104250

LED-24V
500 mm



D12699

LED-24V
1000 mm

p. 203 SMD98

LED



D11399

LED-24V
1500 mm

p. 205 FPL93



193200



001726

p. 217 FE88



188110

C5W



Faisceau p. 276
Harness p. 276
Anschlusskabel siehe S. p. 276

S H3 p.240



D12263* H3/70W-24V

* Lampe fournie
* Bulb included
* Inklusiv Glühlampen

7P



611520 24N

611540 24S

FCA

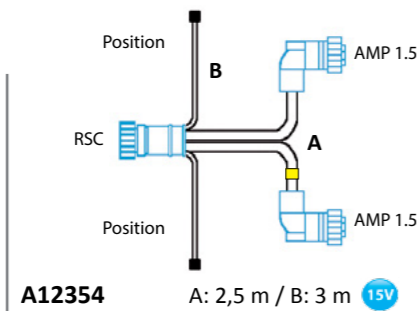

A12354 A: 2,5 m / B: 3 m 15V

Faisceau pour feux arrière avec câbles plats position, surmoulages coudés
Rear lamp cable with position flat cables and 90° overmoulding
Leitungssatz für Heckleuchten mit gewinkeltem Stecker und Flachbandkabel für Positionsleuchte
■ = gauche - left - links

PRL

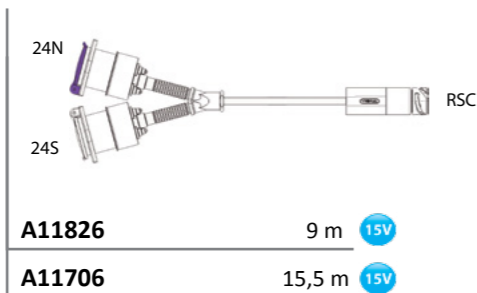

A11826 9 m 15V

A11706 15,5 m 15V

CP



D11268 16 m

Câble plat - Flat cable - Flachkabel

4330012

Bouchon pour câble plat
Cap for flat cable
Abschlussstopfen für Flachkabel

New



164000 LED-24V



DT4

New



LED-24V **165020**

gauche - left - links



DT4
arrière
rear connector
Anschlussstecker hinten



164010 LED-24V

Pour raccordement sur feu BL15
To plug in BL15 lamp
Zum direkten Anschluss an die Leuchte BL15



165030 LED-24V

droit - right - rechts



Exemple de montage - Assembly suggestion - Montagebeispiel

p.185 CTL15

LED

p.185 BL15

LED

p.166 LC8T



156040

gauche - left - links

AMP 1.5
arrière
rear connector
Anschlussstecker hinten

156050

droit - right - rechts

156060

gauche - left - links

156070

droit - right - rechts

056700

gauche - left - links

056710

droit - right - rechts



Faisceau p. 276
Harness p. 276
Anschlusskabel siehe S. p. 276

LC8 p. 160

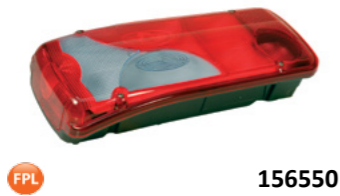

156550
gauche - left - links

AMP 1.5
arrière
rear connector
Anschlussstecker hinten

156540
droit - right - rechts



056000
gauche - left - links

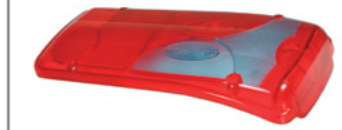

056010
droit - right - rechts



001846

LC7T p. 176

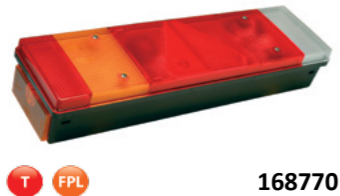

168770
gauche - left - links

PE
arrière
rear connector
Anschlussstecker hinten

168790
droit - right - rechts



067610
gauche - left - links



067600
droit - right - rechts



Faisceau p. 276
Harness p. 276
Anschlusskabel siehe S. p. 276

p. 173 LC7



168270
gauche - left - links

PE
arrière
rear connector
Anschlussstecker hinten

168270
droit - right - rechts



067500
gauche - left - links



067500
droit - right - rechts

p. 193 EPP96



196020 R10W

p. 221 DX



D10642



610080



D11797 3000 mm
Pour module de jonction 175020
For junction box 175020
Für Verteilerdose 175020



D11899 500 mm
Pour repiquage sur feu arrière LC8
To plug in LC8 rear lamp
Zum direkten Anschluss an die Heckleuchte LC8



Faisceau p. 276
Harness p. 276
Anschlusskabel siehe S. p. 276

SL 850 p.231

LED



D14288

Feu homologué recul - Homologated reverse lamp - Genehmigt Rückfahrleuchte

MDJ p.275



175020

7P p.268



611520



24N



611540

24S

15P p.270



A10060



T FPL

156040

gauche - left - links



AMP 1.5
arrière
rear connector
Anschlussstecker hinten



T FPL

156050

droit - right - rechts



T

056700

gauche - left - links



T

056710

droit - right - rechts



Faisceau p. 276
Harness p. 276
Anschlusskabel siehe S. p. 276

p.176 LC7T



T FPL

168770

gauche - left - links



PE
arrière
rear connector
Anschlussstecker hinten



T FPL

168790

droit - right - rechts



T

067610

gauche - left - links



T

067600

droit - right - rechts

p.278 FCA



D13726

Capot de protection pour connectique coudée feu arrière
Protective cover for rear lamp 90° connector
Schutzhülle für Heckleuchte mit gewinkeltem Stecker

EPP96 p.193



SMD98 p.203

LED



Faisceau p. 276
Harness p. 276
Anschlusskabel siehe S. p. 276



FE94 p.204



DXLC8 p.219



LC8T p.166

EPP96 p.193



SMD98 p.203

LED

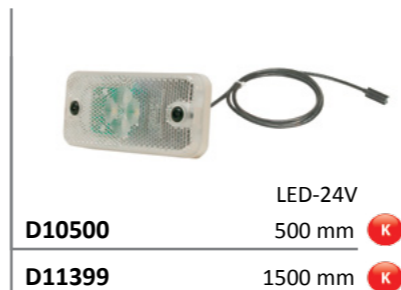

DX p.221

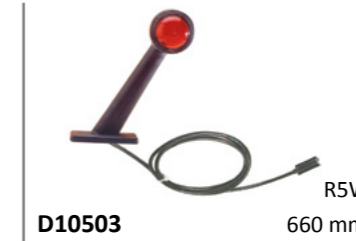

FCA

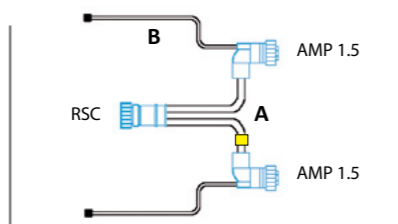

A11317 A: 2 m / B: 13 m ^{16V}

Faisceau pour feux arrière avec câbles plats et surmoulages coudés
Rear lamp cable with flat cables and 90° overmoulding
Leitungssatz für Heckleuchten mit gewinkeltem Stecker und Flachkabel
= gauche - left - links

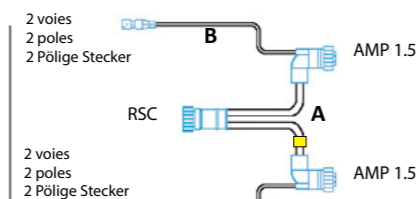

A13538 A: 2,5 m / B: 300 mm ^{16V}

Faisceau pour feux arrière avec câbles plats et surmoulages coudés
Rear lamp cable with flat cables and 90° overmoulding
Leitungssatz für Heckleuchten mit gewinkeltem Stecker und Flachkabel
= gauche - left - links



D13726

Capot de protection pour connectique coudée feu arrière
Protective cover for rear lamp 90° connector
Schutzkappe für Heckleuchte mit gewinkeltem Stecker

PRL

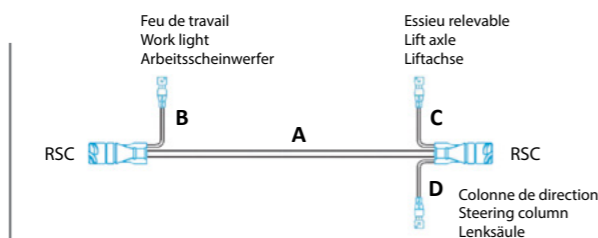

A11316 A: 16 m / B: 1 m / C: 500 mm / D: 300 mm ^{16V}

Câble d'alimentation principale RSC avec multiples connecteurs 2 voies
RSC main supply cable with multiple 2 poles connectors
RSC Hauptkabel mit mehreren 2 poligen Steckern

MDJ

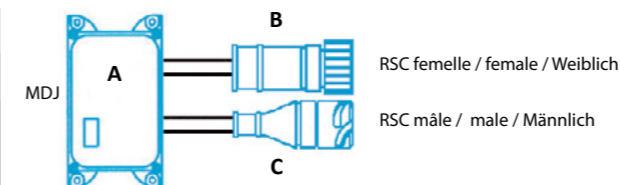

A 175020

B A13473 500 mm ^{16V}

C A13472 500 mm ^{16V}

Interface module de jonction pour dérivations multiples
Junction box with multiple entries
Verteilerbox für mehrere Anschlüsse

ADP

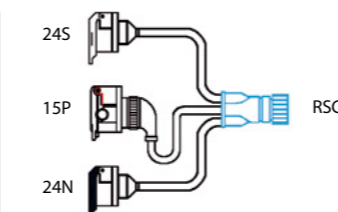

A13816 300 mm ^{16V}

Faisceau prises 15P / 24N / 24S
Cable with plugs 15P / 24N / 24S
Anschlusskabel mit Steckdosen 15P / 24N / 24S

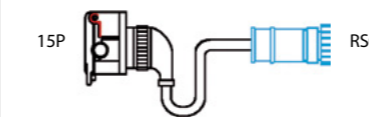

D13254 1000 mm ^{16V}

Faisceau prises 15P
Cable with plugs 15P
Anschlusskabel mit Steckdosen 15P

CP

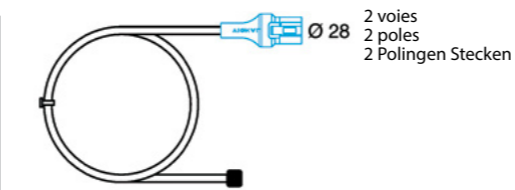

D10520 16 m

Pour / For / Für LC8



LC12T p.153

LED



161000
gauche - left - links



AMP 1.5
arrière
rear connector
Anschlusstecker hinten



161010
droit - right - rechts

LC8T p.166



156060
gauche - left - links



AMP 1.5
arrière
rear connector
Anschlusstecker hinten



156070
droit - right - rechts



001830 ASR



056700
gauche - left - links



056710
droit - right - rechts

EPP96 LED p.192

LED



D13609 LED-24V
400 mm



Faisceau p. 276
Harness p. 276
Anschlusskabel siehe S. p. 276

p.193 EPP96



196020 R10W

p.219 DXLC8



D13034
gauche - left - links



D13035
droit - right - rechts

p.220 DX LED

LED



D14427
gauche - left - links



D14428
droit - right - rechts

p.203 SMD98

LED



D10500 2 x LED-24V
500 mm **K**
D11399 1500 mm **K**

FE94 p.204

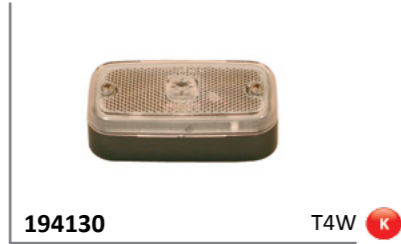

194130 T4W



094036



194030 T4W



094016

SMD04 p.210

LED

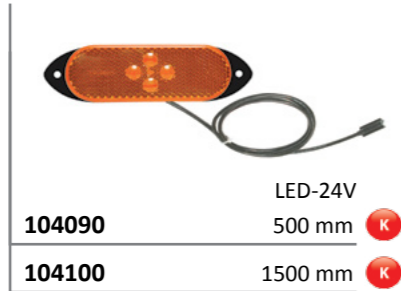

104090 LED-24V 500 mm
104100 LED-24V 1500 mm

ASR p.253



Multi-Frequency
12/24V 97 db
D13810 1500 mm

FCA

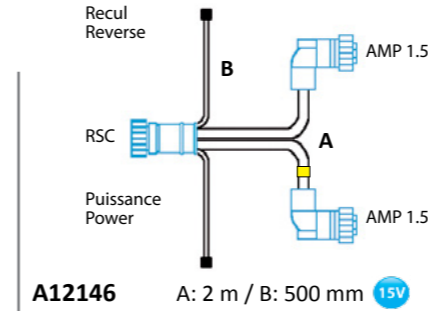

A12146 A: 2 m / B: 500 mm

Faisceau pour feux arrière avec câbles plats puissance et recul, surmoulages coudés
Rear lamp cable with power and reverse flat cables and 90° overmoulding
Leitungssatz für Heckleuchten mit gewinkeltem Stecker und Flachkabel für Spannungsversorgung und Rückfahrcheinwerfer
■ = gauche - left - links

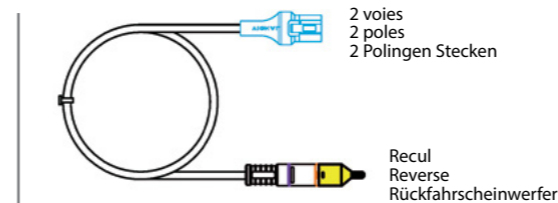

A11440 6000 mm

Câble rond ADR avec connecteur 2 voies stop et connecteur haldex
ADR Round cable with 2 poles stop connector and haldex connector
Rundes ADR-Kabel mit 2 polig stecker für Bremslicht und Haldex Stecker



D13726
Capot de protection pour connectique coudée feu arrière
Protective cover for rear lamp 90° connector
Schutzkappe für Heckleuchte mit gewinkeltem Stecker

Pour / For / Für LC8



FCA

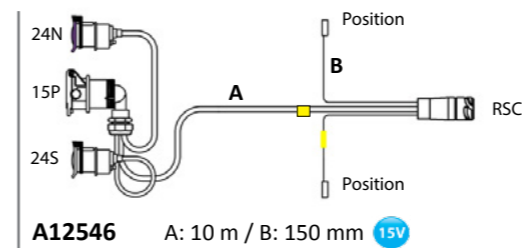

A12546 A: 10 m / B: 150 mm

Câble d'alimentation principale avec adaptateur avant 24N / 24S / 15P et câbles plats
Main supply cable with front adapter 24N / 24S / 15P and flat cables
Hauptkabel mit vorderem Adapter 24N / 24S / 15P und Flachbandkabeln
■ = gauche - left - links

CP

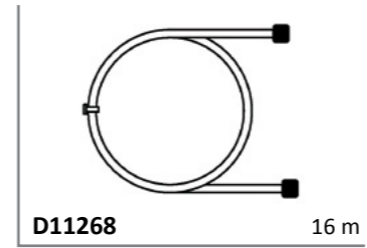

D11268 16 m

Câble plat - Flat cable - Flachkabel



4330012

Bouchon pour câble plat
Cap for flat cable
Abschlussstopfen für Flachkabel

LC12T p. 153

LED



161000
gauche - left - links



AMP 1.5
arrière
rear connector
Anschlusstecker hinten



161010
droit - right - rechts

LC8T p. 166



156040
gauche - left - links



AMP 1.5
arrière
rear connector
Anschlusstecker hinten



156050
droit - right - rechts



056700
gauche - left - links

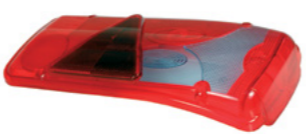

056710
droit - right - rechts

LC8 p. 160



156310
gauche - left - links



AMP 1.5
arrière
rear connector
Anschlusstecker hinten

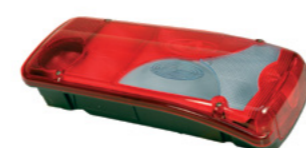

156300
droit - right - rechts

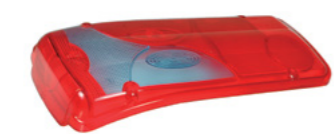

056500
gauche - left - links

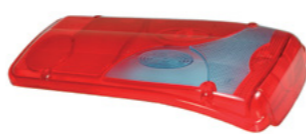

056510
droit - right - rechts



Faisceau p. 276
Harness p. 276
Anschlusskabel siehe S. p. 276

LC5T p. 170



153000
gauche - left - links



AMP 1.5
arrière
rear connector
Anschlusstecker hinten



153010
droit - right - rechts

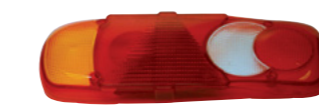

053700
gauche - left - links



053710
droit - right - rechts



152200
gauche - left - links



AMP 1.5
arrière
rear connector
Anschlusstecker hinten



152200
droit - right - rechts



052000
gauche - left - links



052000
droit - right - rechts

LC5 p. 169



Faisceau p. 276
Harness p. 276
Anschlusskabel siehe S. p. 276

LC7 p.173



168270
gauche - left - links



PE
arrière
rear connector
Anschlussstecker hinten



168270
droit - right - rechts



067500
gauche - left - links



067500
droit - right - rechts

LC7T p.176



168770
gauche - left - links



PE
arrière
rear connector
Anschlussstecker hinten



168790
droit - right - rechts



168780
gauche - left - links



067600
droit - right - rechts



067610
gauche - left - links

p.193 EPP96



196020

p.192 EPP96 LED

LED



D13874 LED-24V
2000 mm

p.203 SMD04

LED



104130 LED-24V
500 mm



104100 LED-24V
1500 mm

Pour / For / Für LC8



104170 LED-24V
500 mm

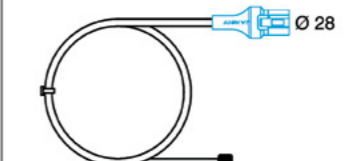

D10520 Ø 28
16 m

p.211 SMD98

LED



198520 4xLED-24V



198540 2xLED-24V



D10496 2xLED-24V
1500 mm



D10497 2xLED-24V
1500 mm



Faisceau p. 276
Harness p. 276
Anschlusskabel siehe S. p. 276

FE04 p. 226

LED



104330 LED-24V
500 mm

DX p. 219



D12428

DX LED p. 220

LED



D13875 LED-12/24V
1000 mm

S H3 p. 233



D12390*

Feu homologué recul - Homologated reverse lamp - Genehmigt Rückfahrleuchte

* Lampe fournie
* Bulb included
* Inklusiv Glühlampen

15P p. 258



A10060



A10061



611520 24N



611540 24S

7P p. 256



175020

MDJ p. 275

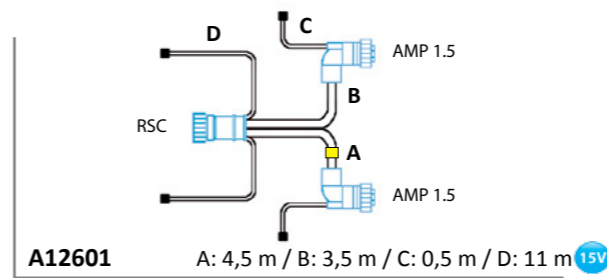

Faisceau pour feux arrière avec câbles plats, surmoulages coudés
Rear lamp cable with flat cables and 90° overmoulding
Leitungssatz für Heckleuchten mit gewinkeltem Stecker und Flachbandkabel
■ = gauche - left - links

FCA

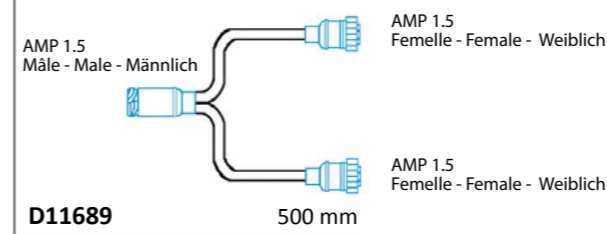

Faisceau doubleur de feux
Cable for double rear lamps
Kabel für zwei Rückleuchten

FCA



D13726

Capot de protection pour connectique coudée feu arrière
Protective cover for rear lamp 90° connector
Schutzkappe für Heckleuchte mit gewinkeltem Stecker

PRL



D13263 15 m ^{15V}

Câble d'alimentation principale RSC simple
Single RSC main supply cable
Haupt-Verlängerungskabel für RSC

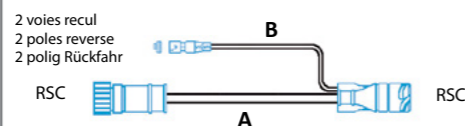

A12435 A: 500 mm / B: 300 mm ^{15V}

Rallonge pour câble d'alimentation principale RSC simple avec câble connecteur 2 voies
Extension lead for single RSC main supply cable with 2 poles connector cable
Verlängerung für Hauptkabel mit Steckdosen RSC mit 2 polig stecker

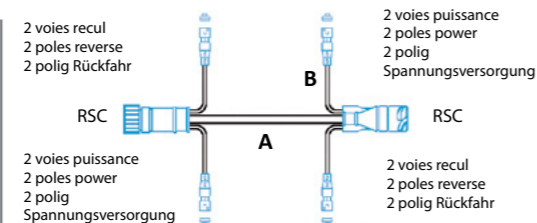

A10537 A: 500 mm / B: 300 mm ^{15V}

Câble d'alimentation principale RSC avec multiples connecteurs 2 voies
RSC main supply cable with multiple 2 poles connectors
RSC Hauptkabel mit mehreren 2 poligen steckern

MDJ

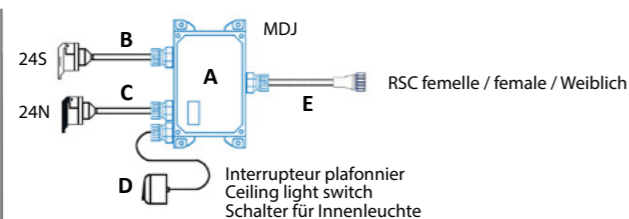

- A** 175020
- B** A12613 500 mm
- C** A12623 500 mm
- D** A12071 700 mm
- E** A12617 300 mm ^{15V}

Interface module de jonction pour dérivations multiples
Junction box with multiple entries
Verteilerbox für mehrere Anschlüsse

MDJ

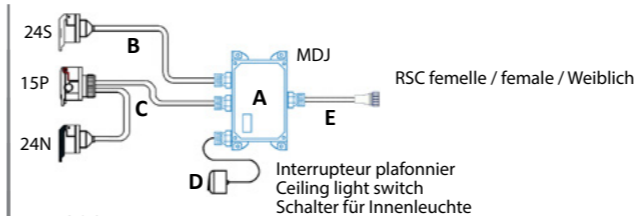

- A** 175020
- B** A12613 500 mm
- C** A12631 500 mm
- D** A12071 700 mm
- E** A12617 300 mm ^{15V}

Interface module de jonction pour dérivations multiples
Junction box with multiple entries
Verteilerbox für mehrere Anschlüsse

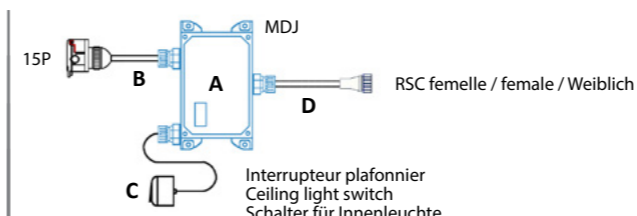

- A** 175020
- B** A12434 500 mm
- C** A12071 700 mm
- D** A12617 300 mm ^{15V}

Interface module de jonction pour dérivations multiples
Junction box with multiple entries
Verteilerbox für mehrere Anschlüsse

p. 258

7P-15P



D13889

CP

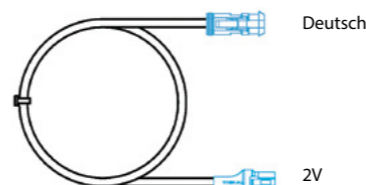

A12483 4500 mm

Câble rond avec connecteurs 2 voies position et deutsch pour feu de travail
Round cable with 2 poles connector and deutsch connectors for work lamp
Rundes Kabel mit 2 poligen Stecker und Deutsch Stecker für den Arbeitsscheinwerfers

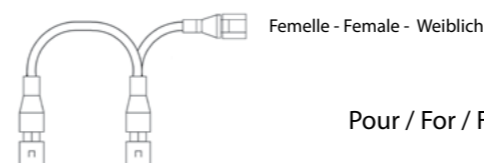

R13676 300 mm

^{15V} Connecteur RSC 15 voies
15 pin RSC connector
15 poliger RSC Stecker

^{15V} Connecteur RSC 15 voies
15 pin RSC connector
15 poliger RSC Stecker

LC8T p.166



156250
gauche - left - links



156260
droit - right - rechts



156380
gauche - left - links



156390
droit - right - rechts



056720
gauche - left - links



056730
droit - right - rechts

LC5T p.170



153000
gauche - left - links



153010
droit - right - rechts

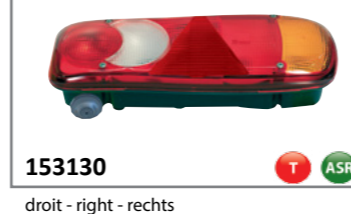

153130
droit - right - rechts

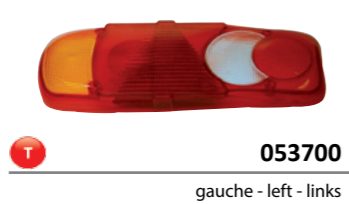

053700
gauche - left - links

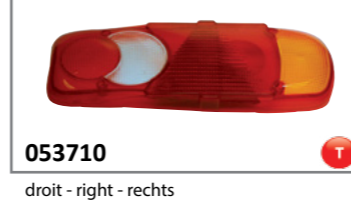

053710
droit - right - rechts



Faisceau p. 276
Harness p. 276
Anschlusskabel siehe S. p. 276

FCA p.269



D13726
Capot de protection pour connectique coudée feu arrière
Protective cover for rear lamp 90° connector
Schutzkappe für Heckleuchte mit gewinkeltem Stecker



D13725
Capot de protection pour connectique droite feu arrière
Protective cover for rear lamp straight connector
Schutzkappe für Heckleuchte mit geradem Stecker

SMD04 p.203

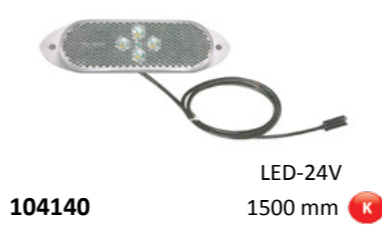

104140
LED-24V
1500 mm **K**



104100
LED-24V
1500 mm **K**



104250
LED-24V
500 mm **K**

FPL93 p.209



193200 **K**

SMD98 p.211



D10494
LED-24V
500 mm **K**



001786
LED-24V
500 mm **K**

LC12T p.153

LED



161000
gauche - left - links



AMP 1.5
arrière
rear connector
Anschlussstecker hinten



161010
droit - right - rechts

LC5TDX p.171



153660
gauche - left - links



AMP 1.5
arrière
rear connector
Anschlussstecker hinten



153670
droit - right - rechts



053700
gauche - left - links

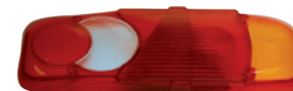

053710
droit - right - rechts

LC5T p.170



153000
gauche - left - links



AMP 1.5
arrière
rear connector
Anschlussstecker hinten



153010
droit - right - rechts



153130
droit - right - rechts



053700
gauche - left - links



053710
droit - right - rechts



Faisceau p. 276
Harness p. 276
Anschlusskabel siehe S. p. 276

p.169 LC5



152180
gauche - left - links



AMP 1.5
arrière
rear connector
Anschlussstecker hinten



152180
droit - right - rechts



052500
gauche - left - links

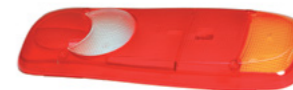

052500
droit - right - rechts



D13288

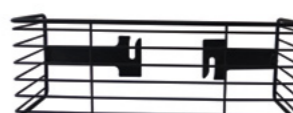

D13288

p.193 EPP96



D11888 1000 mm

p.192 EPP96 LED



D13874 LED-24V
2000 mm



Faisceau p. 276
Harness p. 276
Anschlusskabel siehe S. p. 276

SMD04 p.203

LED



PRL

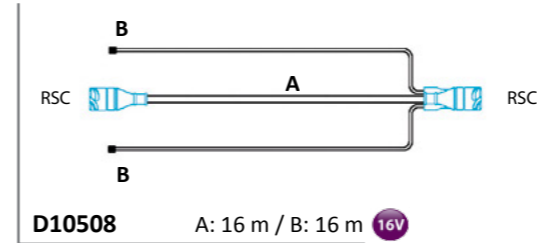

Câble d'alimentation principale RSC avec câbles plats
Single RSC main supply cable with flat cables
Haupt-Verlängerungskabel für RSC mit Flachkabel

S H3 p.233

* Lampe fournie
* Bulb included
* Inklusiv Glühlampen



ADP

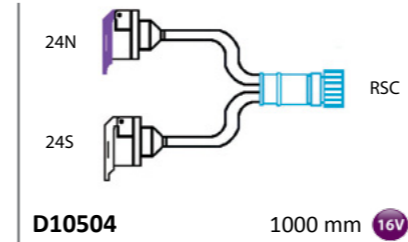

Faisceau prises 24N / 24S
Cable with plugs 24N / 24S
Anschlusskabel mit Steckdosen 24N / 24S

MDJ p.275

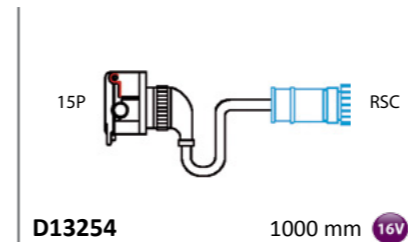

Faisceau prises 15P
Cable with plugs 15P
Anschlusskabel mit Steckdosen 15P

FCA

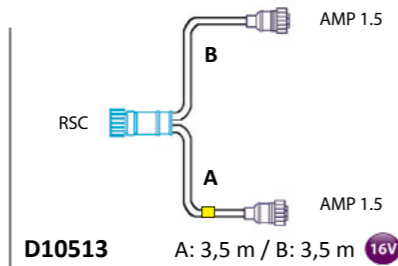

Faisceau pour feux arrière avec surmoulages droits
Rear lamp cable with straight overmoulding
Leitungssatz für Heckleuchten mit geradem Anschlussstecker
= gauche - left - links

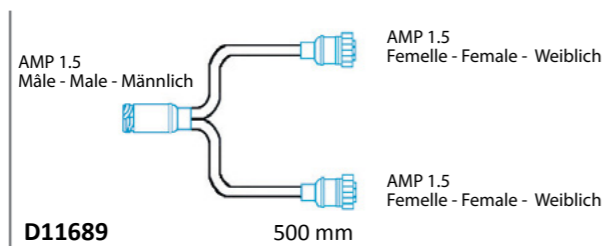

Faisceau doubleur de feux
Cable for double rear lamps
Kabel für zwei Rückleuchten

LC12T p.153

LED



161000
gauche - left - links



AMP 1.5
arrière
rear connector
Anschlussstecker hinten



161010
droit - right - rechts

LC7T p.176



168770
gauche - left - links



PE
arrière
rear connector
Anschlussstecker hinten



168790
droit - right - rechts



067610
gauche - left - links



067600
droit - right - rechts

EPP96 p.193



196020 R10W



Faisceau p. 276
Harness p. 276
Anschlusskabel siehe S. p. 276

p.204 **FE94**



194130 T4W **K**



094036 **K**



194010 T4W **K**

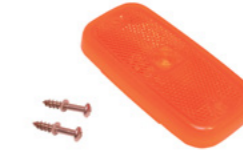

094016 **K**

p.221 **DX**



D10642 R5W



D10503 R5W
660 mm

p.231 **SL 850**

LED



D14288
Feu homologué recul - Homologated reverse lamp - Genehmigt Rückfahrleuchte

p.275 **MDJ**



175020

LC7T p.176



168770
gauche - left - links



PE
arrière
rear connector
Anschlussstecker hinten



168790
droit - right - rechts



067610
gauche - left - links



067600
droit - right - rechts

LC5TDX p.171



153660
gauche - left - links



AMP 1.5
arrière
rear connector
Anschlussstecker hinten



153670
droit - right - rechts



Faisceau p. 276
Harness p. 276
Anschlusskabel siehe S. p. 276



053700
gauche - left - links



053710
droit - right - rechts

EPP96 p.193



196020 R10W



D11888 1000 mm

EPP96 LED p.192

LED



D13874 LED-24V
2000 mm

p.211 SMD98

LED



D11399 LED-24V
1500 mm

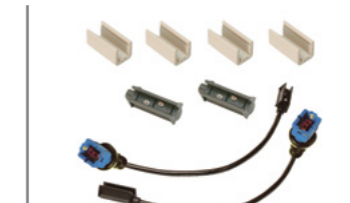

001806 1500 mm



198520 LED-24V

p.215 SMD00

LED



198620 LED-24V

p.221 DX



D10642 R5W



D10503 R5W
660 mm

p.275 MDJ



175020



Faisceau p. 276
Harness p. 276
Anschlusskabel siehe S. p. 276

LC8T

p. 166



156060
gauche - left - links



AMP 1.5
arrière
rear connector
Anschlussstecker hinten



156070
droit - right - rechts



156630
gauche - left - links



AMP 1.5
latéral
side connector
Anschlussstecker seitlich



156640
droit - right - rechts



056700
gauche - left - links



056710
droit - right - rechts

SMD98

p. 216

LED



D10497
LED-24V
1500 mm



001776
LED-24V
1500 mm

p. 171

LC5TDX



153660
gauche - left - links



AMP 1.5
arrière
rear connector
Anschlussstecker hinten



153670
droit - right - rechts



053700
gauche - left - links



053710
droit - right - rechts



Faisceau p. 276
Harness p. 276
Anschlusskabel siehe S. p. 276

p. 169

LC5



152130
gauche - left - links



PG
arrière
rear connector
Anschlussstecker hinten



152130
droit - right - rechts



052000
gauche - left - links



052000
droit - right - rechts

p. 173

LC7



168270
gauche - left - links



PE
arrière
rear connector
Anschlussstecker hinten



168270
droit - right - rechts



067500
gauche - left - links



067500
droit - right - rechts



Faisceau p. 276
Harness p. 276
Anschlusskabel siehe S. p. 276

LC6 p.185



166000

gauche - left - links



PE
arrière
rear connector
Anschlussstecker hinten



166000

droit - right - rechts



166100

gauche - left - links



166100

droit - right - rechts



066000

gauche - left - links



066000

droit - right - rechts

EPP96 p.193



196020

R10W



D10502

410 mm

FE04 p.210

LED



104290

LED-24V
500 mm

104310

3000 mm



104330

LED-24V
500 mm

104360

5000 mm

p.211 SMD04

LED



104520

LED-24V
1000 mm

adhésif - adhesive - selbstklebend

p.211 SMD98

LED



198660

LED-24V



001716



D12867

LED-24V
300 mm



198540

LED-24V



Faisceau p. 276
Harness p. 276
Anschlusskabel siehe S. p. 276

p.208 FE94



194130

T4W



094036



194020

T4W



194030

T4W



094016

FE88

p.221



188110

C5W



088010

cabochon - lens - Lichtscheibe

DX

p.221



D10642

R5W

CT

p.247



623016

MDJ

p.275



175020

FCA

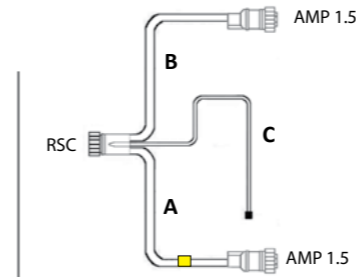

D13262 A: 1,5 m / B: 2,5 m / C: 1,2 m ^{15V}

Faisceau pour feux arrière avec câbles plats et surmoulages coudés
Rear lamp cable with flat cables and 90° overmoulding
Leitungssatz für Heckleuchten mit gewinkeltem Stecker und Flachkabel für
■ = gauche - left - links

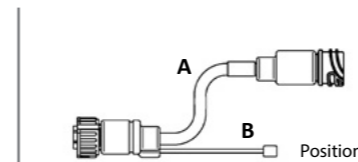

R12576 * A: 0,5 m / B: 3 m

PRL

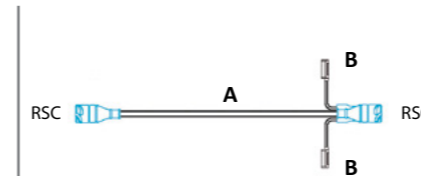

D13260 A: 15 m / B: 300 mm ^{15V}

Câble d'alimentation principale RSC avec câbles plats autoporants
Single RSC main supply cable with flat cables with click-in
Haupt-Verlängerungskabel für RSC mit Flachbandkabeln

MDJ

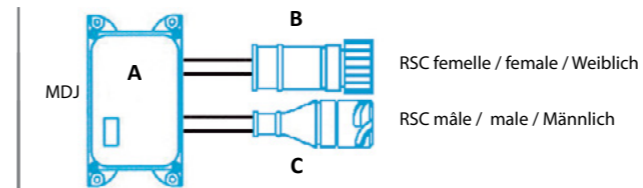

A 175020

B A12657 500 mm ^{15V}

C A12659 500 mm ^{15V}

Interface module de jonction pour dérivations multiples
Junction box with multiple entries
Verteilerbox für mehrere Anschlüsse

ADP

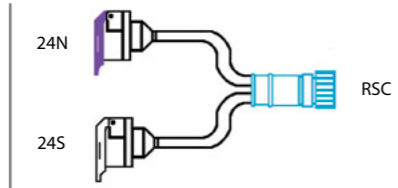

D13257 1500 mm 15V

Faisceau prises 24N / 24S
Cable with plugs 24N / 24S
Anschlusskabel mit Steckdosen 24N / 24S

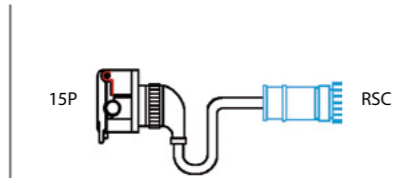

D13255 600 mm 15V

Faisceau prises 15P
Cable with plugs 15P
Anschlusskabel mit Steckdosen 15P

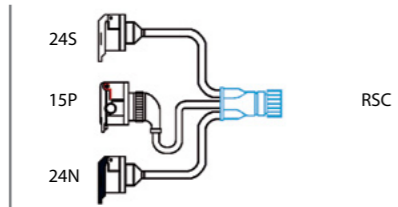

D13256 300 mm 15V

Faisceau prises 15P / 24N / 24S
Cable with plugs 15P / 24N / 24S
Anschlusskabel mit Steckdosen 15P / 24N / 24S

CP

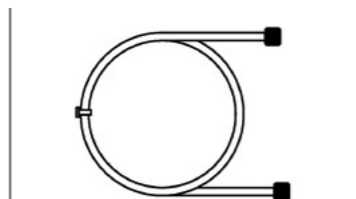

D11268 16 m

Câble plat - Flat cable - Flachkabel



001796 500 mm



4330012

Bouchon pour câble plat
Cap for flat cable
Abschlussstopfen für Flachkabel

New



161000

gauche - left - links



AMP 1.5
arrière
rear connector
Anschlussstecker hinten



161010

droit - right - rechts

p. 153

LC12T

LED



Faisceau p. 276
Harness p. 276
Anschlusskabel siehe S. p. 276

LC8T p.166



156040
gauche - left - links



156050
droit - right - rechts



056700
gauche - left - links



056710
droit - right - rechts

EPP96 p.193



D11888 1000 mm

SMD04 p.211

LED

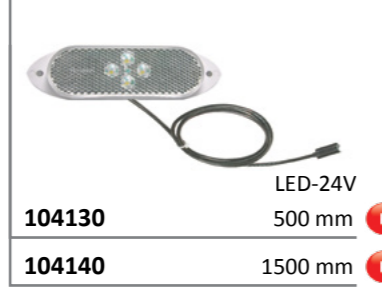

104130 LED-24V 500 mm **K**
104140 LED-24V 1500 mm **K**



104250 LED-24V 500 mm **K**
104260 LED-24V 1500 mm **K**

FE94 p.208



Faisceau p. 276
Harness p. 276
Anschlusskabel siehe S. p. 276



194130 T4W **K**



094036 **K**

p.216 SMD98

LED



D10494 LED-24V 500 mm **K**
D10497 LED-24V 1500 mm **K**

p.221 DX

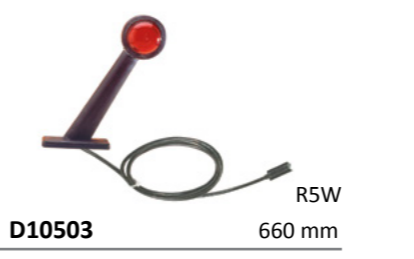

D10503 R5W 660 mm



Faisceau p. 276
Harness p. 276
Anschlusskabel siehe S. p. 276

LC12T p.153

LED



161000
gauche - left - links



AMP 1.5
arrière
rear connector
Anschlussstecker hinten



161010
droit - right - rechts

LC8T p.166



156040
gauche - left - links



AMP 1.5
arrière
rear connector
Anschlussstecker hinten



156050
droit - right - rechts



001830
droit - right - rechts



056700
gauche - left - links



056710
droit - right - rechts

EPP96 p.193



196020 R10W



Faisceau p. 276
Harness p. 276
Anschlusskabel siehe S. p. 276

p.211 SMD04

LED



104130 LED-24V 500 mm
104140 1500 mm

p.221 DX



D10642 R5W



D10643 R5W



D10503 R5W 660 mm

p.220 DX LED

LED



D14427
gauche - left - links



D14428
droit - right - rechts

p.221 DX LED



D13624 LED 12/24V

SL 850 p. 231

LED



D14288

Feu homologué recul - Homologated reverse lamp - Genehmigt Rückfahrleuchte

FCA

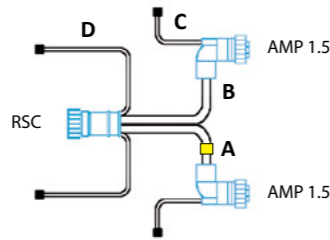

A13152 A: 2,5 m / B: 1,8 m / C: 0,5 m / D: 1,5 m ^{16V}

Faisceau pour feux arrière avec câbles plats, surmoulages coudés
Rear lamp cable with flat cables and 90° overmoulding
Leitungssatz für Heckleuchten mit gewinkeltem Stecker und Flachbandkabel
= gauche - left - links

PRL

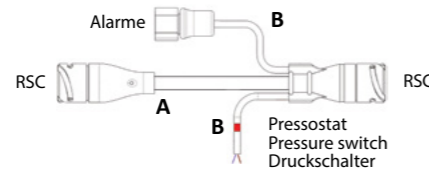

A13087 A: 14 m / B: 5 m ^{16V}

Câble d'alimentation principale RSC simple + raccordement pressostat et alarme
Single RSC main supply cable + pressure switch and alarm connections
Haupt-Verlängerungskabel für RSC + Anschluss für Druckschalter und Signalhorn

ADP

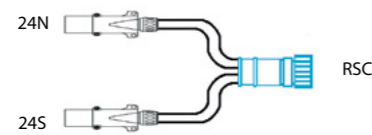

A13086 300 mm ^{16V}

Faisceau fiches 24N / 24S
Cable with plugs 24N / 24S
Anschlusskabel mit Steckdosen 24N / 24S

CP

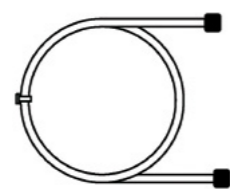

D11268 16 m

Câble plat - Flat cable - Flachkabel



4330012

Bouchon pour câble plat
Cap for flat cable
Abschlussstopfen für Flachkabel

LC8T p. 166



156040

gauche - left - links



AMP 1.5
arrière
rear connector
Anschlussstecker hinten



156050

droit - right - rechts



156060

gauche - left - links



056700

gauche - left - links

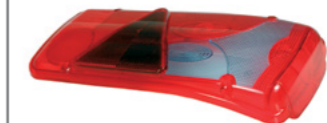

056710

droit - right - rechts



196020

R10W



D10642

R5W



D10503

R5W
660 mm



Faisceau p. 276
Harness p. 276
Anschlusskabel siehe S. p. 276

EPP96 p. 193

DX p. 221

Feux de position - Position lamps - Positionsluchten
Face latérale - Side face - Seitenansicht

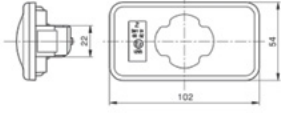

SMD00

LED

ADR

E2 1295

Affectations constructeurs
OE applications
Fahrzeugverwendung
RENAULT TRUCKS p. 45
VOLVO TRUCKS p. 80

198620 LED-24V

Cuve blanche - cabochon PMMA
White body - PMMA lens
Weißes Gehäuse - PMMA Lichtscheibe

198740 LED-24V

Cuve ambre - cabochon PC haute température
Amber body - PC lens high temperature
Oranger Gehäuse - PC Lichtscheibe hoch temperatur beständig

SMD98

LED

ADR

E2 8040

p. 203

p. 222

Affectations constructeurs
OE applications
Fahrzeugverwendung
IRISBUS p. 17
IVECO p. 25
MANITOWOC p. 38
RENAULT TRUCKS p. 45
VOLVO TRUCKS p. 80

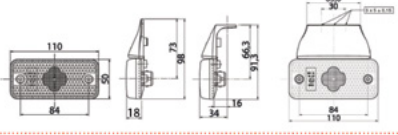

198510 4 x LED-12V

198520 4 x LED-24V

198530 2 x LED-24V

198540 2 x LED-24V

198580 4 x LED-12V

198760 SUPERSEAL 4 x LED-24V

AMP JPT
arrière
rear connector
Anschlussstecker hinten

Faisceau p. 276
Harness p. 276
Anschlusskabel siehe S. p. 276

VIGNAL
LIGHTING GROUP

211

Référence Vignal
Vignal p/n
Art.-Nr. Vignal

Nom du produit
Product name
Produktbezeichnung

n° d'homologation
Homologation number
Homologationsnummer

Sens de montage
Assembling position
Montagehinweis

Report affectations constructeurs
Reference to OE applications
Hinweise zur Fahrzeugverwendung

Symbole fonctions
Functions symbol
Funktionssymbole

ORIGINAL QUALITY PARTS

Lampe
Bulb
Glühlampe

Référence Vignal
Vignal p/n
Art.-Nr. Vignal



198620 LED-24V

Cuve blanche - cabochon PMMA
White body - PMMA lens
Weißes Gehäuse - PMMA Lichtscheibe

Symbole fonctions
Functions symbol
Funktionssymbole

Spécificité du produit
Product specificity
Besonderheit des Produkts

Feux arrière - Rear lamps - Heckleuchten

Feux multifonction - Multifunction lamps - Mehrkammerleuchten

 p. 152	 p. 154	 p. 157	 p. 158	 p. 159
 p. 160	 p. 162	 p. 163	 p. 165	 p. 166
 p. 168	 p. 169	 p. 170	 p. 171	 p. 173
 p. 176	 p. 177	 p. 178	 p. 179	 p. 179
 p. 180	 p. 182	 p. 183	 p. 193	 p. 184
 p. 184	 p. 186	 p. 187	 p. 188	 p. 188
 p. 189	 p. 189	 p. 189	 p. 190	 p. 190
 p. 191	 p. 191	 p. 192	 p. 192	 p. 192

LC12T



LC12T

New

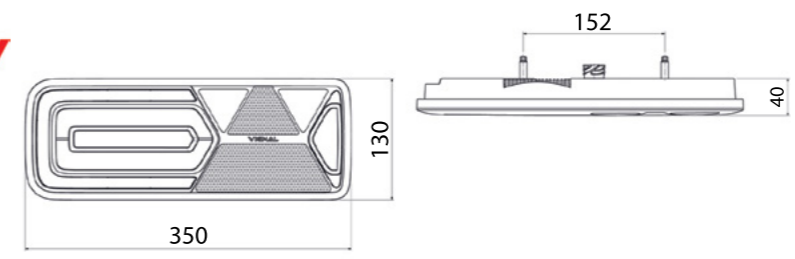

LED
 ADR
 E2 16027
 10R-0516057

AMP 1.5
 arrière
 rear connector
 Anschlussstecker hinten

161000 LED-24V
161200 LED-12V

gauche - left - links

161010 LED-24V
161210 LED-12V

droit - right - rechts

161190 LED-24V

gauche - left - links

Version sans triangle disponible fin 2017
 Version without triangle available end of 2017
 Version ohne Dreiecksrückstrahler Ende 2017 verfügbar

161180 LED-24V

droit - right - rechts

Affectations constructeurs
 OE applications
 Fahrzeugverwendung
 ASCA p. 89
 BENALU p. 95
 BTK p. 101
 FRUEHAUF p. 114
 LAMBERET p. 118
 LOUAULT p. 128
 MAGYAR p. 132
 SCHMITZ p. 143
 TABARRINI p. 146

Resistance intégrée (contrôle défaillance indicateur)
 Integrated resistance (indicator failure control)
 Integrierter widerstand (blinkleuchtenausfallkontrolle)

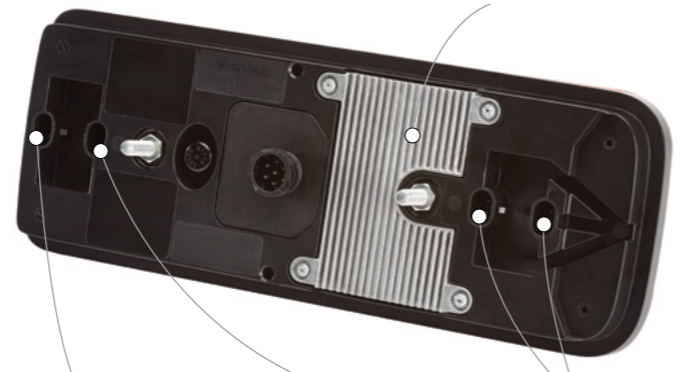

Position latéral clignotant
 Side marker flashing lamp
 Blinkende seitens markierungs leuchte

Recul
 Reverse
 Rückfahr

Position
 Schlußlicht

4 connecteurs additionnels (2 voies SUPERSEAL)
 additional connectors (SUPERSEAL 2 pin)
 zusätzliche elektrische anschlüsse (2 poliger SUPERSEAL)

Clignotant dynamique ou défilant
 Dynamic Indicator
 Dynamisch wischender Blinker

Gestion des feux de position latéraux clignotants, supplément 6 - R48.
 Management of side marker flashing lamps, supplement 6 - R48
 Ansteuerung der seitlichen Blinkleuchten gemäß der Erweiterung 6 - R48



Pièces détachées - Spare part - Ersatzteile

R14413 1500 mm

2 voies DT femelle
 Female 2 poles DT connector
 Weiblich Anschlussstecker 2 polig

Connecteur SUPERSEAL 2 voies femelle
 2 poles female SUPERSEAL connector
 Weiblich Anschlussstecker 2 polig

D14288 DT 2V

Feu homologué recul - Homologated reverse lamp - Genehmigt Rückfahrleuchte

Faisceau p. 276
 Harness p. 276
 Anschlusskabel siehe S. p. 276

R14412 16 m

Connecteur SUPERSEAL 2 voies femelle
 2 poles female SUPERSEAL connector
 Weiblich Anschlussstecker 2 polig

104090 LED-24V 500 mm
104100 LED-24V 1500 mm

New **R14364** LED-24V 2000 mm

Connecteur SUPERSEAL 2 voies femelle
 2 poles female SUPERSEAL connector
 Weiblich Anschlussstecker 2 polig

New **D14425** LED-12/24V 1500 mm gauche - left - links
D14426 LED-12/24V 1500 mm droit - right - rechts

Connecteur SUPERSEAL 2 voies femelle
 2 poles female SUPERSEAL connector
 Weiblich Anschlussstecker 2 polig

ORIGINAL QUALITY PARTS

ORIGINAL QUALITY PARTS

LC11

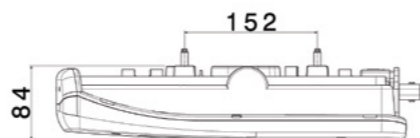
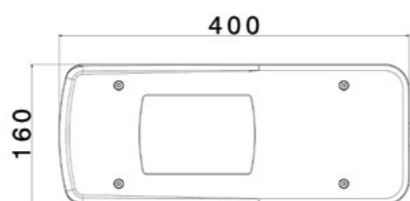

**VERSION AMP 1.5
 COMPATIBLE
 SCANIA**

LED

ADR



E2 14085
 14086
 10R-047585

New



LED-24V
 K FPL EPP
160060
 gauche - left - links



AMP 1.5
 arrière
 rear connector
 Anschlussstecker hinten



LED-24V
 K FPL
160070
 droit - right - rechts



LED-24V
 K FPL
160020
 gauche - left - links



AMP 1.5
 latéral
 side connector
 Anschlussstecker seitlich



LED-24V
 K FPL
160030
 droit - right - rechts



LED-24V
 K FPL EPP
160000
 gauche - left - links

Pièces détachées - Spare part - Ersatzteile



K
060000
 gauche - left - links



K
060010
 droit - right - rechts



D11868 AMP 1.5



Faisceau p. 276
 Harness p. 276
 Anschlusskabel siehe S. p. 276

LC11

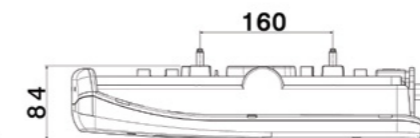
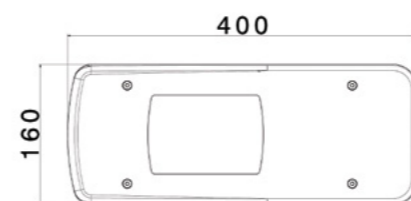

**VERSION HDSCS
 COMPATIBLE
 DAF**

LED

ADR



E2 14085
 14086
 10R-047585



LED-24V
 K FPL EPP
160200
 gauche - left - links



HDSCS
 latéral
 side connector
 Anschlussstecker seitlich



LED-24V
 K FPL
160230
 droit - right - rechts



LED-24V
 K FPL EPP
160240
 gauche - left - links



HDSCS
 arrière
 rear connector
 Anschlussstecker hinten



LED-24V
 K FPL
160270
 droit - right - rechts

Pièces détachées - Spare part - Ersatzteile



K
060000
 gauche - left - links



K
060010
 droit - right - rechts



D13878 HDSCS



Faisceau p. 276
 Harness p. 276
 Anschlusskabel siehe S. p. 276

LC11

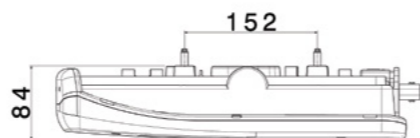
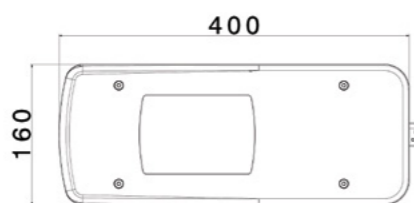

LED



E2 14085
 14086
 10R-047585

Affectations constructeurs
 OE applications
 Fahrzeugverwendung
 IVECO p. 25



LED-24V
 K FPL
160150
 gauche - left - links



HDSCS
 latéral
 side connector
 Anschlussstecker seitlich



LED-24V
 K FPL
160100
 droit - right - rechts



LED-24V
 K FPL EPP
160080
 gauche - left - links



LED-24V
 K FPL ASR
160090
 droit - right - rechts



LED-24V
 K FPL
160110
 gauche - left - links



HDSCS
 arrière
 rear connector
 Anschlussstecker hinten



LED-24V
 K FPL
160130
 droit - right - rechts



LED-24V
 K FPL EPP
160140
 gauche - left - links



LED-24V
 K FPL ASR
160120
 droit - right - rechts

Pièces détachées - Spare part - Ersatzteile



K
060000
 gauche - left - links



K
060010
 droit - right - rechts



D13878 HDSCS



Faisceau p. 276
 Harness p. 276
 Anschlusskabel siehe S. p. 276

LC10 LED

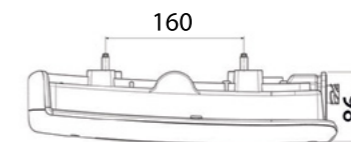
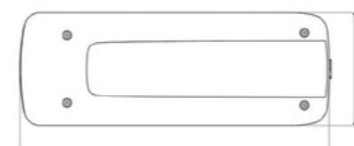

LED



E2 12164
 10R-036854

Affectations constructeurs
 OE applications
 Fahrzeugverwendung
 VOLVO TRUCKS p. 80



LED-24V
 K FPL
159520
 gauche - left - links



AMP 1.5
 latéral
 side connector
 Anschlussstecker seitlich



LED-24V
 K FPL
159530
 droit - right - rechts



LED-24V
 K FPL EPP
159500
 gauche - left - links



LED-24V
 K FPL ASR
159510
 droit - right - rechts

Pièces détachées - Spare part - Ersatzteile



059500
 gauche - left - links



059500
 droit - right - rechts



D11868 AMP 1.5



Faisceau p. 276
 Harness p. 276
 Anschlusskabel siehe S. p. 276

LC9 LED

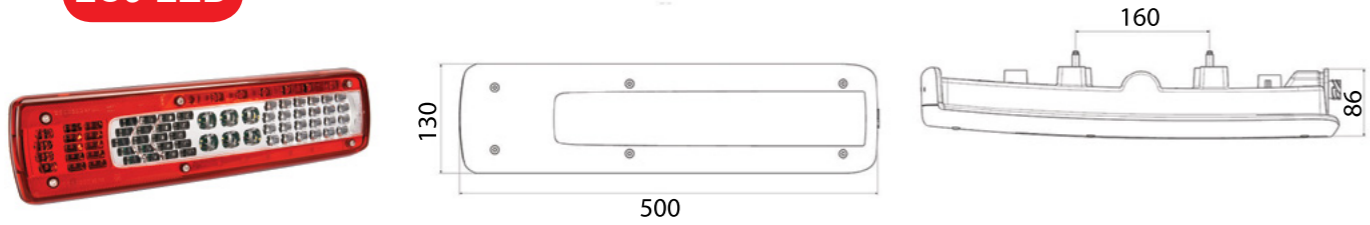

LED



E2 10113
10R-036227

Affectations constructeurs
 OE applications
 Fahrzeugverwendung
RENAULT TRUCKS p. 45
VOLVO TRUCKS p. 80



LED-24V
158030
 K FPL EPP

gauche - left - links



AMP 1.5
 latéral
 side connector
 Anschlussstecker seitlich



158050
 LED-24V
 K FPL

droit - right - rechts



158040
 LED-24V
 K FPL ASR

droit - right - rechts

Pièces détachées - Spare part - Ersatzteile



058000

gauche - left - links



058000

droit - right - rechts



D11868

AMP 1.5



Faisceau p. 276
 Harness p. 276
 Anschlusskabel siehe S. p. 276

LC9

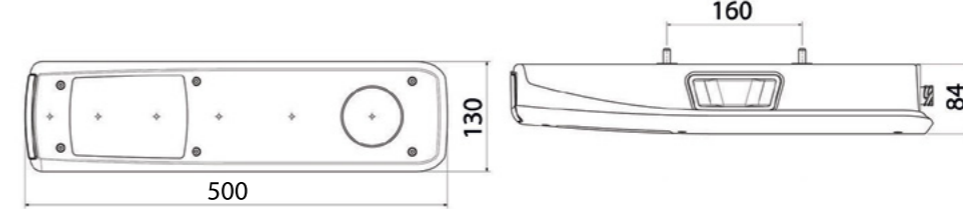

159010
 LED-24V
 K FPL EPP

gauche - left - links



AMP 1.5
 latéral
 side connector
 Anschlussstecker seitlich



159020
 LED-24V
 K FPL

droit - right - rechts



159030
 LED-24V
 K FPL ASR

droit - right - rechts



E2 04075

Affectations constructeurs
 OE applications
 Fahrzeugverwendung
RENAULT TRUCKS p. 45
VOLVO TRUCKS p. 80

Pièces détachées - Spare part - Ersatzteile



059000

gauche - left - links



059000

droit - right - rechts

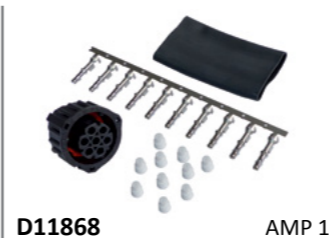

D11868

AMP 1.5



D12953

ASR



Faisceau p. 276
 Harness p. 276
 Anschlusskabel siehe S. p. 276

LC8

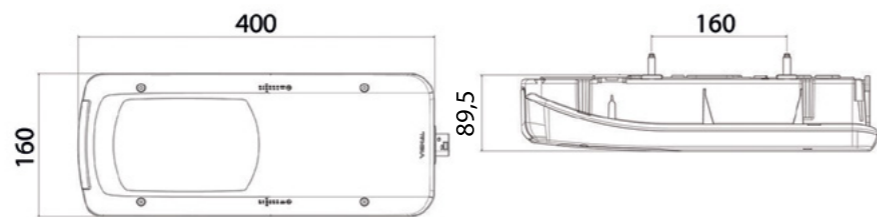

E2 12007

Affectations constructeurs
 OE applications
 Fahrzeugverwendung
 DAF p. 9



155100

gauche - left - links



HDSCS
 latéral
 side connector
 Anschlussstecker seitlich



155110

droit - right - rechts



155120

droit - right - rechts



155130

gauche - left - links



HDSCS
 arrière
 rear connector
 Anschlussstecker hinten



155140

droit - right - rechts



155150

droit - right - rechts

Pièces détachées - Spare part - Ersatzteile



055020

gauche - left - links



055030

droit - right - rechts



D13878

HDSCS



001830



Faisceau p. 276
 Harness p. 276
 Anschlusskabel siehe S. p. 276

LC8

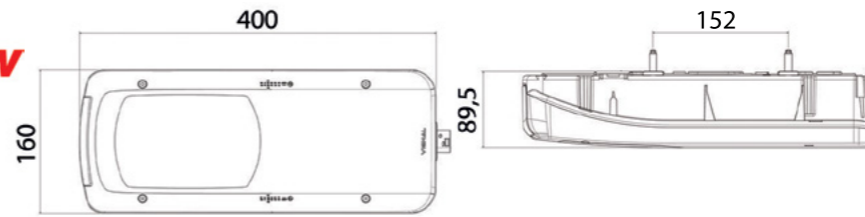

E2 12007

Affectations constructeurs
 OE applications
 Fahrzeugverwendung
 VOLKSWAGEN p. 79



155570

gauche - left - links



AMP 1.5
 arrière
 rear connector
 Anschlussstecker hinten



155580

droit - right - rechts

Pièces détachées - Spare part - Ersatzteile



055020

gauche - left - links



055030

droit - right - rechts



D11868

AMP 1.5



Faisceau p. 276
 Harness p. 276
 Anschlusskabel siehe S. p. 276

LC8

New

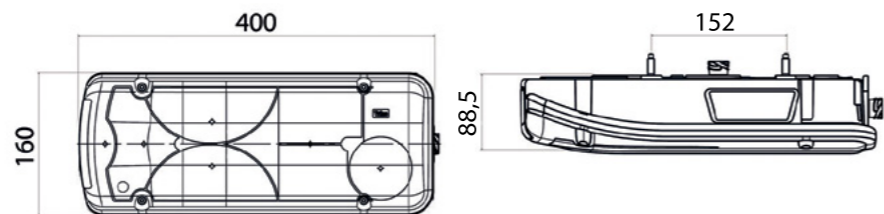

ADR



E2 2040

Affectations constructeurs
 OE applications
 Fahrzeugverwendung
 IVECO p. 25

DESIGN EFFET FUMÉ - MÉTALLISÉ
 SMOKED EFFECT & METALLIZED DESIGN



HDSCS
 latéral
 side connector
 Anschlussstecker seitlich



155460 K FPL

droit - right - rechts



155470 K FPL ASR

droit - right - rechts



HDSCS
 arrière
 rear connector
 Anschlussstecker hinten



155490 K FPL

droit - right - rechts



155540 K FPL EPP

gauche - left - links



155500 K FPL ASR

droit - right - rechts

Pièces détachées - Spare part - Ersatzteile



055040 K

gauche - left - links



055050 K

droit - right - rechts



D13878 HDSCS



001830 ASR

Faisceau p. 276
 Harness p. 276
 Anschlusskabel siehe S. p. 276

LC8

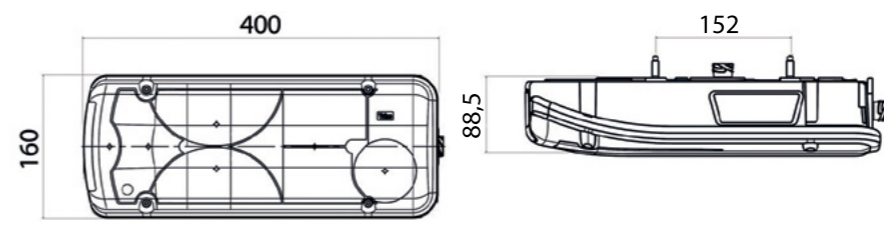

ADR



E2 2040

Affectations constructeurs
 OE applications
 Fahrzeugverwendung
 MAN p. 35



AMP 1.5
 latéral
 side connector
 Anschlussstecker seitlich

156200 K FPL EPP

gauche - left - links



156210 K FPL

droit - right - rechts

New



001872 55-90 db ASR



156220 K FPL ASR

droit - right - rechts

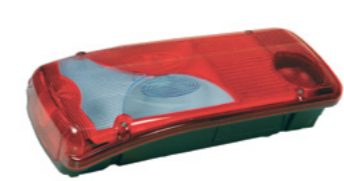

AMP 1.5
 arrière
 rear connector
 Anschlussstecker hinten

156550 FPL

gauche - left - links

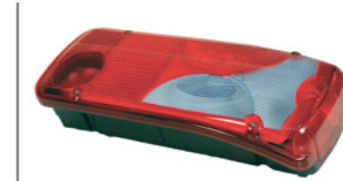

156540 FPL

droit - right - rechts

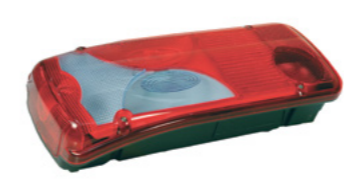

156310 K FPL

gauche - left - links

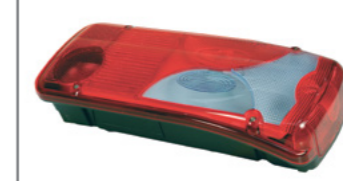

156300 K FPL

droit - right - rechts

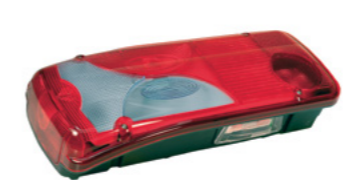

156290 K FPL EPP

gauche - left - links

Pièces détachées - Spare part - Ersatzteile



056000 K

gauche - left - links



056010 K

droit - right - rechts

Feux arrière - Rear lamps - Heckleuchten

Feux multifonction - Multifunction lamps - Mehrkammerleuchten

LC8

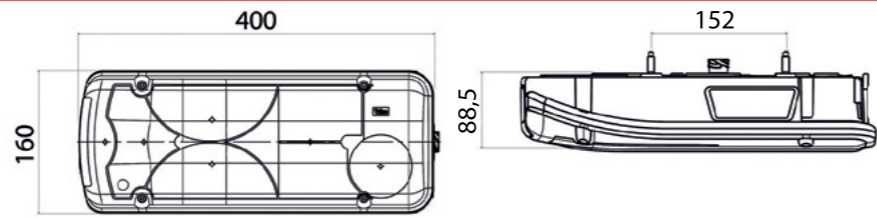

ADR



E2 2040

Affectations constructeurs
OE applications
Fahrzeugverwendung
MAN (VUL) p. 35

* vis arrière de 31 mm
* 31 mm rear bolts
* hintere Schraube 31 mm

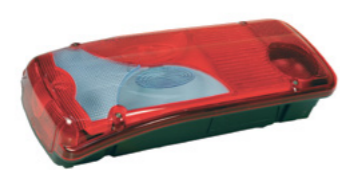

K FPL

155550*

gauche - left - links



AMP 1.5
arrière
rear connector
Anschlussstecker hinten

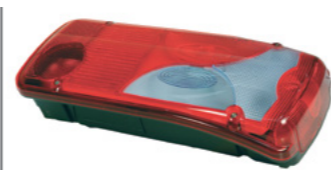

K FPL

155560*

droit - right - rechts

Pièces détachées - Spare part - Ersatzteile



K

056500

gauche - left - links

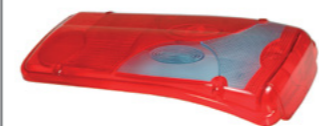

K

056510

droit - right - rechts

LC8

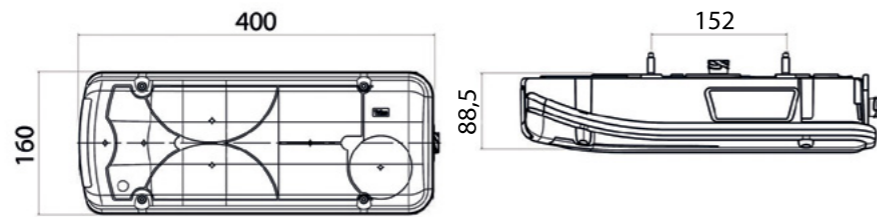

ADR



E2 2040

Affectations constructeurs
OE applications
Fahrzeugverwendung
SCANIA p. 76



Faisceau p. 276
Harness p. 276
Anschlusskabel siehe S. p. 276



K FPL EPP

156770

gauche - left - links



AMP 1.5
latéral
side connector
Anschlussstecker seitlich



K FPL

156780

droit - right - rechts



K FPL

155020

gauche - left - links



K FPL ASR

156790

droit - right - rechts

Pièces détachées - Spare part - Ersatzteile



K

056020

056540

gauche - left - links



056030

056550

droit - right - rechts



D11868

AMP 1.5



001830

ASR



AMP 1.5
arrière
rear connector
Anschlussstecker hinten



K FPL EPP

155080

gauche - left - links



K FPL

155520

droit - right - rechts



K FPL ASR

155090

droit - right - rechts



Faisceau p. 276
Harness p. 276
Anschlusskabel siehe S. p. 276

Feux arrière - Rear lamps - Heckleuchten

Feux multifonction - Multifunction lamps - Mehrkammerleuchten

LC8

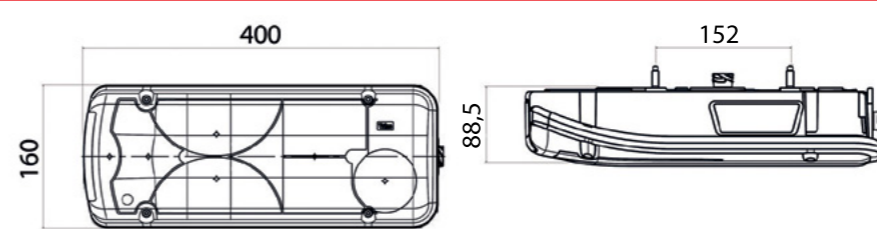

ADR



E2 2040

Affectations constructeurs
OE applications
Fahrzeugverwendung
MERCEDES p. 40
VOLKSWAGEN p. 79



FPL

156590

gauche - left - links



AMP 1.5
arrière
rear connector
Anschlussstecker hinten



FPL

156600

droit - right - rechts



K FPL EPP

156340

gauche - left - links



K FPL

156350

droit - right - rechts



K FPL EPP

155080

gauche - left - links



AMP 1.5
arrière
rear connector
Anschlussstecker hinten



K FPL

155520

droit - right - rechts



K FPL ASR

155090

droit - right - rechts

Affectations constructeurs
OE applications
Fahrzeugverwendung
SCANIA p. 76

LC8T

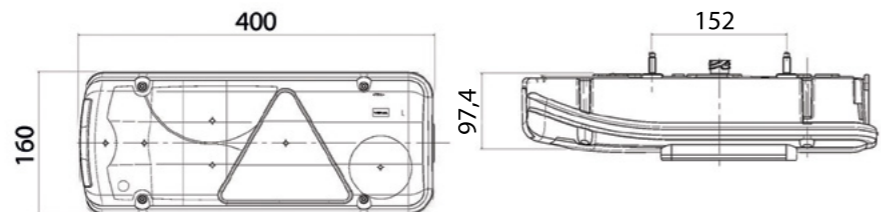

E2 2040

Affectations constructeurs
 OE applications
 Fahrzeugverwendung
 p. 89



156040
 gauche - left - links



156060
 gauche - left - links



AMP 1.5
 arrière
 rear connector
 Anschlussstecker hinten

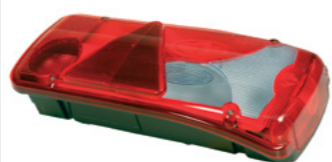

156050
 droit - right - rechts



156070
 droit - right - rechts

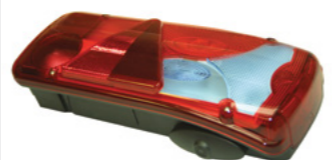

156130
 droit - right - rechts



156150
 droit - right - rechts



156630
 gauche - left - links



AMP 1.5
 latéral
 side connector
 Anschlussstecker seitlich



156640
 droit - right - rechts



Faisceau p. 276
 Harness p. 276
 Anschlusskabel siehe S. p. 276

LC8T



E2 2040

Affectations constructeurs
 OE applications
 Fahrzeugverwendung
 p. 89

Pièces détachées - Spare part - Ersatzteile



056700
 gauche - left - links



056710
 droit - right - rechts



001830



D11868 AMP 1.5

New
LED



D14038
 gauche - left - links



D14037
 droit - right - rechts



D13034
 gauche - left - links



D13035
 droit - right - rechts



D12712
 gauche - left - links



D12711
 droit - right - rechts

Feux arrière - Rear lamps - Heckleuchten

Feux multifonction - Multifunction lamps - Mehrkammerleuchten

LC8T

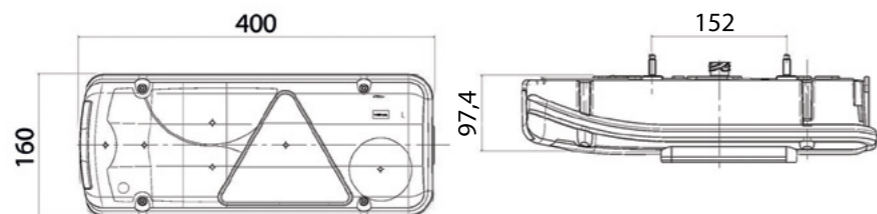

2040

Affectations constructeurs
OE applications
Fahrzeugverwendung
p. 89



156250

gauche - left - links



AMP 1.5
arrière
rear connector
Anschlussstecker hinten



156260

droit - right - rechts



156380

gauche - left - links



156390

droit - right - rechts

Pièces détachées - Spare part - Ersatzteile



056720

gauche - left - links



056730

droit - right - rechts



D11868 AMP 1.5



Faisceau p. 276
Harness p. 276
Anschlusskabel siehe S. p. 276

Feux arrière - Rear lamps - Heckleuchten

Feux multifonction - Multifunction lamps - Mehrkammerleuchten

LC5

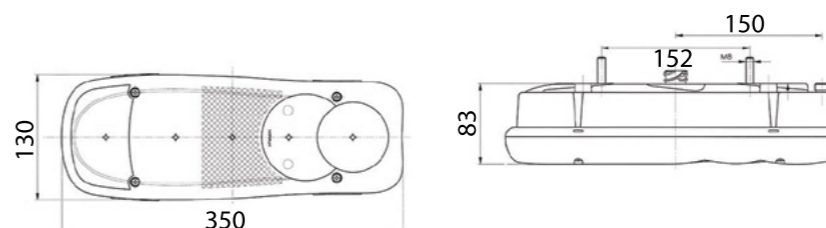

8005

Affectations constructeurs
OE applications
Fahrzeugverwendung

DAF p. 9
FIAT p. 14
IVECO p. 25
MANITOU p. 37
NISSAN p. 41
OPEL p. 42
PSA p. 43
RENAULT TRUCKS p. 45
UD TRUCKS p. 78
VOLVO TRUCKS p. 80



152130

gauche - left - links

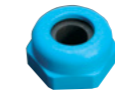

PG 13
arrière
rear connector
Anschlussstecker hinten



152130

droit - right - rechts

152150

gauche - left - links



152160

gauche - left - links

152150

droit - right - rechts

152140

gauche - left - links



152200

gauche - left - links



AMP 1.5
arrière
rear connector
Anschlussstecker hinten



152200

droit - right - rechts

152180

gauche - left - links

152180

droit - right - rechts



152190

gauche - left - links



153120

droit - right - rechts

152170

gauche - left - links

Pièces détachées - Spare part - Ersatzteile



052000

gauche - left - links



052000

droit - right - rechts

052500

gauche - left - links

052500

droit - right - rechts



Faisceau p. 276
Harness p. 276
Anschlusskabel siehe S. p. 276

LC5T

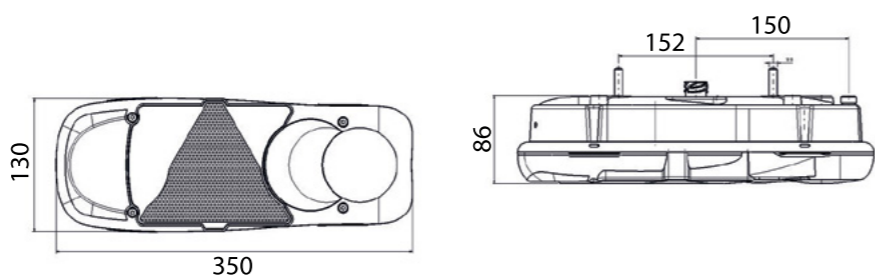

06024

Affectations constructeurs
 OE applications
 Fahrzeugverwendung
 p. 89



153040

gauche - left - links



PG 13
 arrière
 rear connector
 Anschlussstecker hinten



153050

droit - right - rechts



153060

gauche - left - links



153070

droit - right - rechts



AMP 1.5
 arrière
 rear connector
 Anschlussstecker hinten



153000

gauche - left - links



153010

droit - right - rechts



153020

gauche - left - links



153030

droit - right - rechts

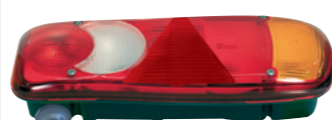

153130

droit - right - rechts



Faisceau p. 276
 Harness p. 276
 Anschlusskabel siehe S. p. 276

LC5TDX

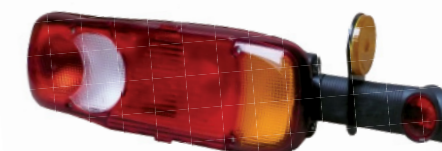
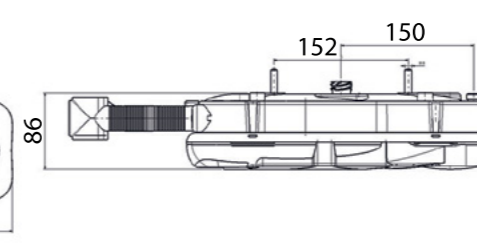
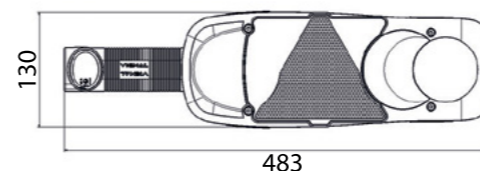

06024 (sans DX)
 07092 (avec DX)

Affectations constructeurs
 OE applications
 Fahrzeugverwendung
 p. 89



153660

gauche - left - links



AMP 1.5
 arrière
 rear connector
 Anschlussstecker hinten



153670

droit - right - rechts



153700

gauche - left - links



153710

droit - right - rechts

Pièces détachées - Spare part - Ersatzteile



053700

gauche - left - links



053710

droit - right - rechts



001746 JPT

Câble pour connection EPP séparé
 Wiring for number plate lamp
 Anschlusskabel für Kennzeichenleuchte



R12934 600 mm

R12931 1200 mm

Raccordement connectique deutsch
 Wiring with deutsch connector
 Anschlussstecker deutsch



D13288

grille de protection réversible - protective grid - Schutzgitter
 homologué - homologated - genehmigt



D11868 AMP 1.5



Faisceau p. 276
 Harness p. 276
 Anschlusskabel siehe S. p. 276

LC5TDX

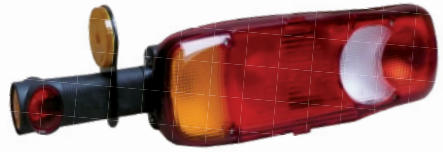

06024 (sans DX)
07092 (avec DX)

Affectations constructeurs
OE applications
Fahrzeugverwendung
p. 89

Pièces détachées - Spare part - Ersatzteile



D12430



D12471



D12472



D12473

LC7

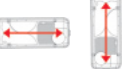
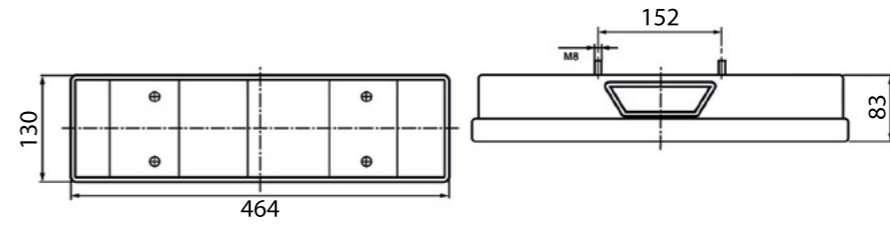

88017 (LC7)
88035 (LC7K)

Affectations constructeurs
OE applications
Fahrzeugverwendung
DAF p. 9
IRISBUS p. 17
IVECO p. 25
MAN p. 35
RENAULT TRUCKS p. 45
SCANIA p. 76

167100

gauche - left - links

PE
arrière
rear connector
Anschlussstecker hinten

167000

gauche - left - links

167600

gauche - left - links

167500

gauche - left - links

168270

gauche - left - links

168270

droit - right - rechts

168340

gauche - left - links

DIN
arrière
rear connector
Anschlussstecker hinten

168090

droit - right - rechts

168090

gauche - left - links

168100

gauche - left - links

LC7

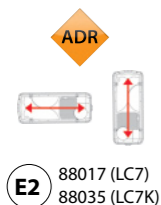
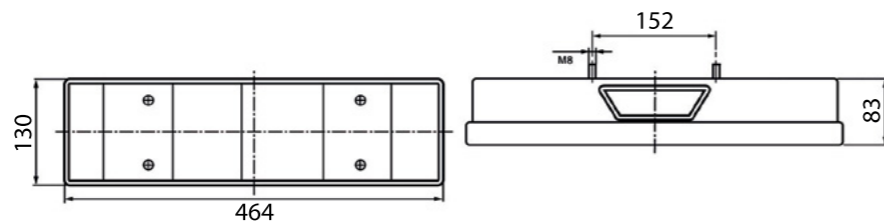

Affectations constructeurs
 OE applications
 Fahrzeugverwendung
 DAF p. 9
 IRISBUS p. 17
 IVECO p. 25
 MAN p. 35
 RENAULT TRUCKS p. 45
 SCANIA p. 76



169180
 gauche - left - links



AMP 1.5
 latéral
 side connector
 Anschlussstecker seitlich



169170
 droit - right - rechts



DIN
 arrière
 rear connector
 Anschlussstecker hinten

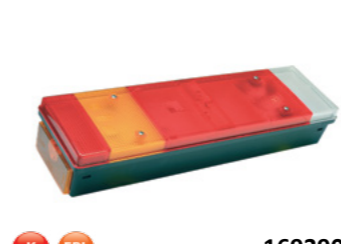

169390
 gauche - left - links



169410
 droit - right - rechts

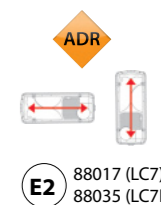

Affectations constructeurs
 OE applications
 Fahrzeugverwendung
 DAF p. 9
 IRISBUS p. 17
 IVECO p. 25
 MAN p. 35
 RENAULT TRUCKS p. 45
 SCANIA p. 76



169160
 gauche - left - links



169280
 droit - right - rechts



169400
 gauche - left - links



169420
 droit - right - rechts



169190
 droit - right - rechts

Pièces détachées - Spare part - Ersatzteile

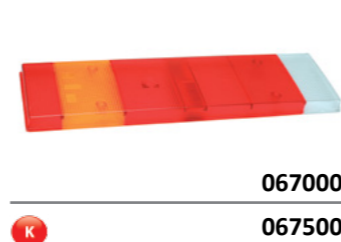

067000
067500
 gauche - left - links

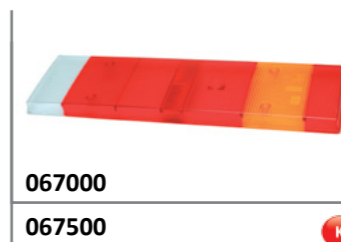

067000
067500
 droit - right - rechts



001706
 silent blocs - schwingungsdämpfer



001656
 Cales - Brocks - Distanzstücke



D11868
 AMP 1.5



D12953
 ASR



168590
 gauche - left - links



IVECO
 arrière
 rear connector
 Anschlussstecker hinten



168600
 droit - right - rechts



168610
 gauche - left - links



168480
 droit - right - rechts



Faisceau p. 276
 Harness p. 276
 Anschlusskabel siehe S. p. 276



Faisceau p. 276
 Harness p. 276
 Anschlusskabel siehe S. p. 276

LC7T

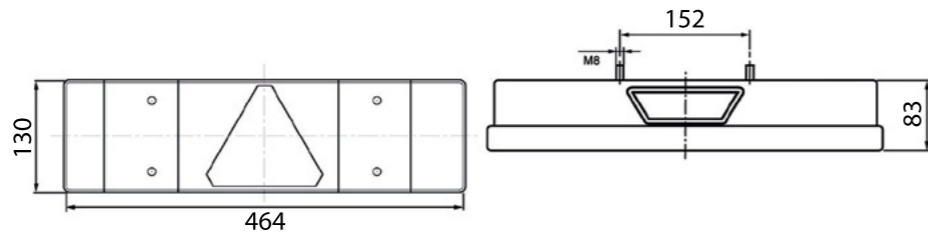
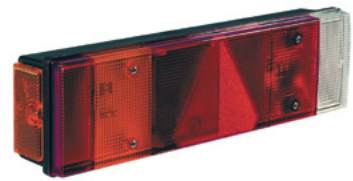

ADR



E2 9056

Affectations constructeurs
 OE applications
 Fahrzeugverwendung
 p. 89



T **167530**

gauche - left - links

T FPL **168770**



T FPL EPP **168780**

gauche - left - links



PE
 arrière
 rear connector
 Anschlussstecker hinten



T **167550**

droit - right - rechts

T FPL **168790**



T FPL EPP **168800**

droit - right - rechts



T FPL ASR **168830**

droit - right - rechts

Pièces détachées - Spare part - Ersatzteile



T **067610**

gauche - left - links



T **067600**

droit - right - rechts

LC6

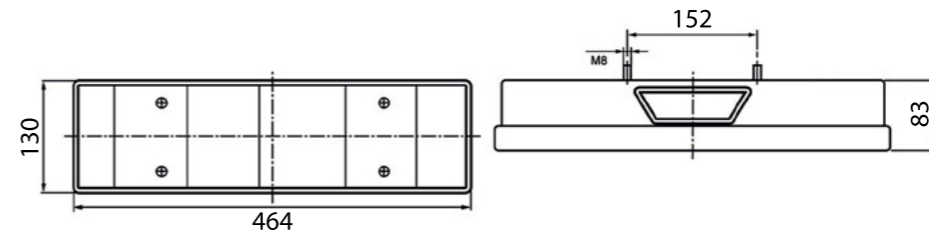

ADR



E2 88033 (LC6)
 88034 (LC6K)

Affectations constructeurs
 OE applications
 Fahrzeugverwendung

HEULIEZ p. 188
 IRISBUS p. 17
 MAN p. 35
 RENAULT TRUCKS p. 45

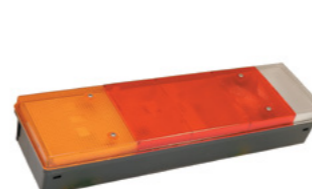

166000

gauche - left - links



PE
 arrière
 rear connector
 Anschlussstecker hinten



166000

droit - right - rechts



EPP **166100**

gauche - left - links



166100 EPP

droit - right - rechts



K EPP **166600**

gauche - left - links



166600 K EPP

droit - right - rechts

Pièces détachées - Spare part - Ersatzteile



K **066000**

gauche - left - links



066500 K

droit - right - rechts

LC4

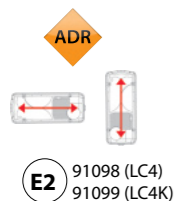
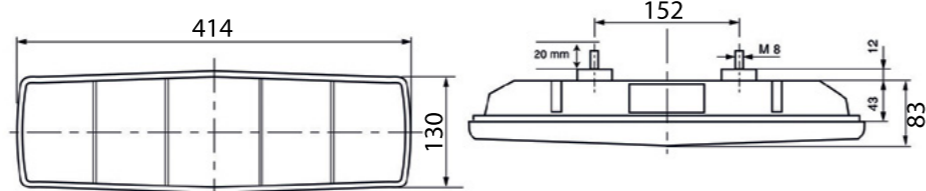

Affectations constructeurs
 OE applications
 Fahrzeugverwendung
 DAF p. 9
 RENAULT TRUCKS p. 45



141000
gauche - left - links



PE
arrière
rear connector
Anschlussstecker hinten

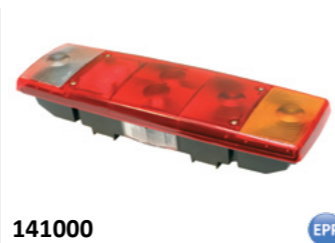

141000
droit - right - rechts



141500
gauche - left - links



141500
droit - right - rechts

Pièces détachées - Spare part - Ersatzteile

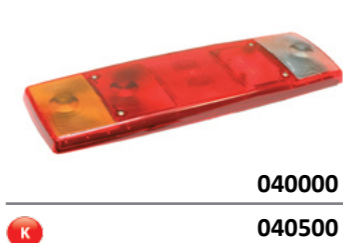

040000
040500
gauche - left - links

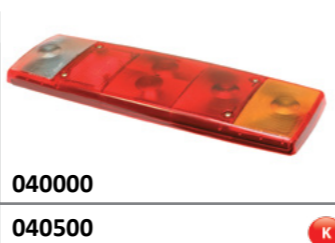

040000
040500
droit - right - rechts



000046

MILI

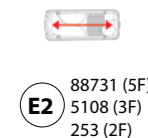
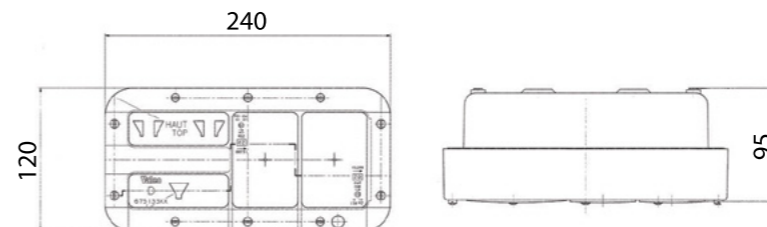

88731 (5F)
 5108 (3F)
 253 (2F)



67513371
gauche - left - links



67513390
cabochon - lens - Lichtscheibe



67513361
droit - right - rechts

67513380
cabochon - lens - Lichtscheibe



60760541
position - clignotant - black out position
 position - indicator - black out position
 schlussleuchte - richtungsanzeiger - black out



60760551
brouillard - recul
 fog - reverse
 neblschlussleuchte - rückfahrleuchte

New

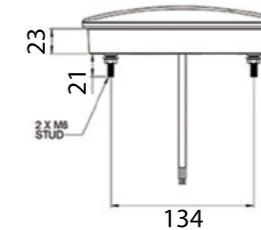
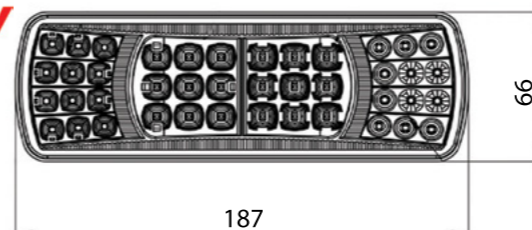

SLIM

LED



11734
 10R-051614

* fils nus - naked cable extre-
 mity - Kabellitze

5 FONCTIONS - FUNCTIONS - FUNKTIONEN



D13817 LED-10/30V
 gauche/droit - left/right - links/rechts

POSITION
 INDICATEUR DE DIRECTION
 STOP
 RECU
 ANTIBROUILLARD

POSITION
 INDICATOR
 STOP
 REVERSE
 FOG

POSITION
 BLINKER
 BREMSLEUCHE
 RÜCKFAHRLEUCHE
 NEBELSCHLUSSLEUCHE



725



47364
52308
52309
52310
52312

Affectations constructeurs
OE applications
Fahrzeugverwendung
IVECO p. 25

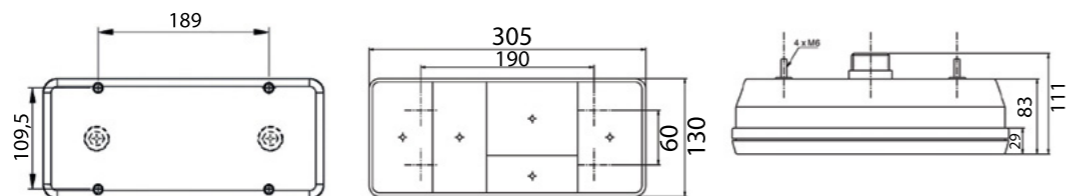

725040

gauche - left - links



IVECO
arrière
rear connector
Anschlussstecker hinten



725000

gauche - left - links



725020

gauche - left - links



IVECO
arrière
rear connector
Anschlussstecker hinten



725010

droit - right - rechts



726310

gauche - left - links

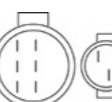

IVECO
arrière
rear connector
Anschlussstecker hinten



726320

droit - right - rechts

725



47364
52308
52309
52310
52312

Affectations constructeurs
OE applications
Fahrzeugverwendung
IVECO p. 25

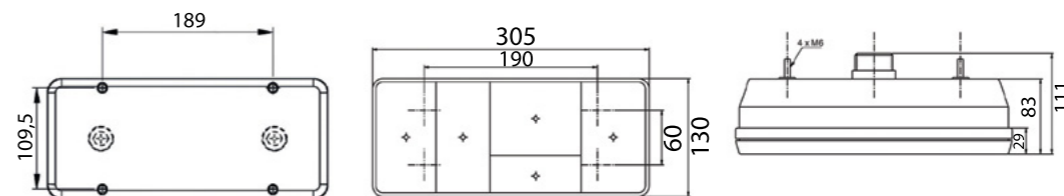

726290

gauche - left - links



IVECO
arrière
rear connector
Anschlussstecker hinten



726300

droit - right - rechts



726350

gauche - left - links



IVECO
arrière
rear connector
Anschlussstecker hinten



726450

gauche - left - links



IVECO
arrière
rear connector
Anschlussstecker hinten



726460

droit - right - rechts

Pièces détachées - Spare part - Ersatzteile



725002

gauche - left - links



725012

droit - right - rechts



725022

gauche - left - links



725032

droit - right - rechts

725



E13 8434

Affectations constructeurs
 OE applications
 Fahrzeugverwendung
 IVECO p. 25

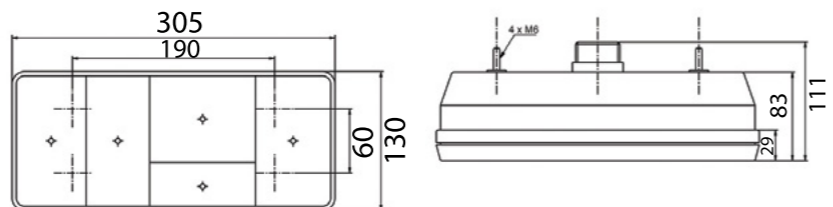

D11482
gauche - left - links



AMP 1.5
arrière
rear connector
Anschlussstecker hinten



D11481
droit - right - rechts

Pièces détachées - Spare part - Ersatzteile



D11480
gauche - left - links



D11479
droit - right - rechts

E13 2060

Affectations constructeurs
 OE applications
 Fahrzeugverwendung
 IVECO p. 25



D12334
gauche - left - links



AMP 1.5
arrière
rear connector
Anschlussstecker hinten



D12335
droit - right - rechts

Pièces détachées - Spare part - Ersatzteile



D12336
gauche - left - links



D12337
droit - right - rechts



Faisceau p. 276
 Harness p. 276
 Anschlusskabel siehe S. p. 276

LA38



E2 864
 1051
 1052

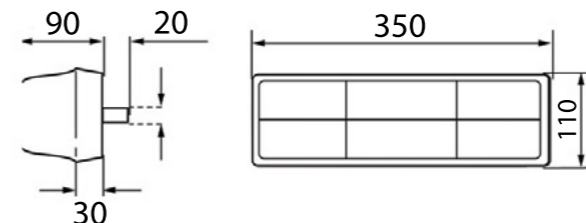

138000
gauche - left - links



PE
arrière
rear connector
Anschlussstecker hinten



138000
droit - right - rechts

Pièces détachées - Spare part - Ersatzteile



038000
gauche - left - links



038000
droit - right - rechts

BBS 516



E1 1559
 53329

Affectations constructeurs
 OE applications
 Fahrzeugverwendung
 MANITOU p. 37

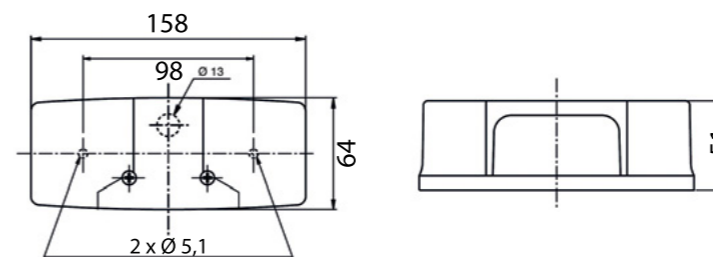

500930
gauche - left - links



PF
arrière
rear connector
Anschlussstecker hinten



500940
droit - right - rechts



500930
gauche - left - links



500940
droit - right - rechts

Feux arrière - Rear lamps - Heckleuchten

Feux multifonction - Multifunction lamps - Mehrkammerleuchten

KIT

LED



E2 16007
10R-0516079

1200 Lumen

Fixation par l'avant
Front fixation
Frontfixierung



A14420 LED-24V
2 x CTL15 + 1 x BL15 gauche + 1 x BL15 droit + 4 câbles
2 x CTL15 + 1 x left BL15 + 1 x right BL15 + 4 cables
2 x CTL15 + 1 x BL15 links + 1 x BL15 rechts + 4 Verkabelung

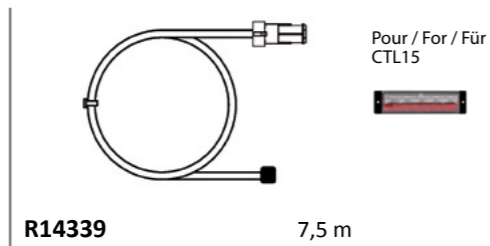

R14339 7,5 m

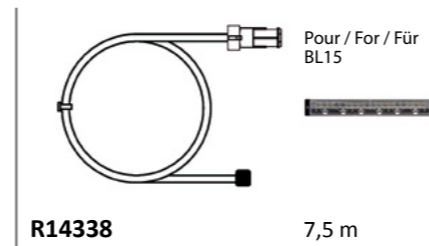

R14338 7,5 m



Sécurité - Confort - Efficacité
Safety - Comfort - Efficiency
Sicherheit - Komfort - Effizienz

Indicateur de direction à défilement - feux de détresse flash
Dynamic indicator lights - warning lights
Dynamischer Blinker - blinkende Warnleuchte



Feu de travail 1200 Lumen
Work light 1200 Lumen
Arbeitsscheinwerfer 1200 Lumen

Stop et position
Stop and position
Bremsleuchte und Schlussleuchte



Feux arrière - Rear lamps - Heckleuchten

Feux multifonction - Multifunction lamps - Mehrkammerleuchten

CTL15

LED



E2 16005

Affectations constructeurs
OE applications
Fahrzeugverwendung
[CHEREAU p.105](#)

New

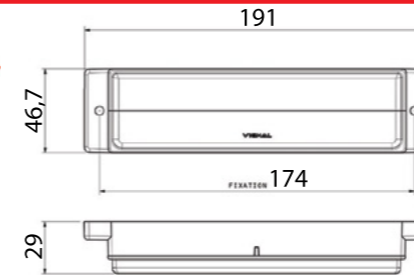

164000 LED-24V

Fixation par l'arrière
Back fixation
Rückenfixierung

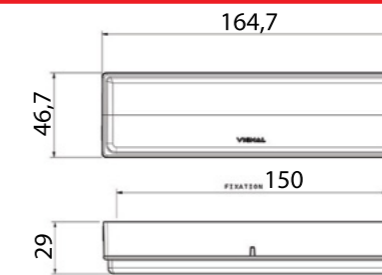

164010 LED-24V

Pour raccordement sur feu BL15
To plug in BL15 lamp
Zum direkten Anschluss an die Leuchte BL15



164020 LED-24V

Fixation par l'avant
Front fixation
Frontfixierung



164030 LED-24V

Pour raccordement sur feu BL15
To plug in BL15 lamp
Zum direkten Anschluss an die Leuchte BL15

New

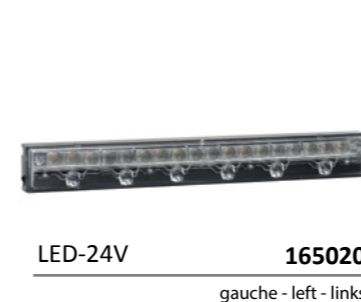
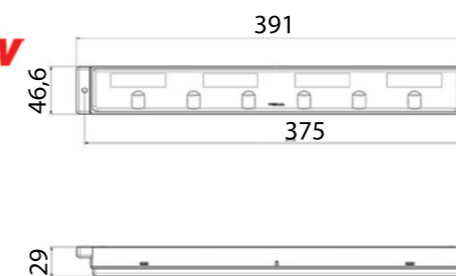

165020 LED-24V
gauche - left - links

DT04
arrière
rear connector
Anschlussstecker hinten

Fixation par l'arrière
Back fixation
Rückenfixierung

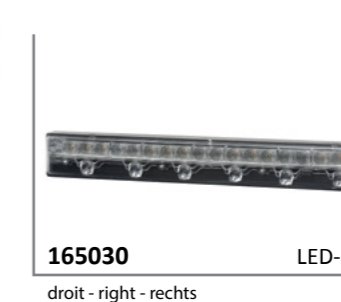
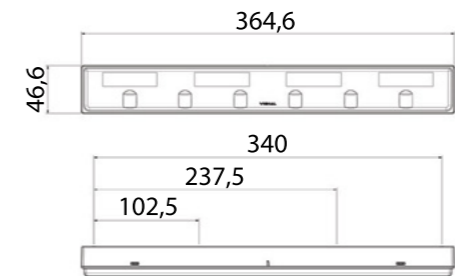

165030 LED-24V
droit - right - rechts

BL15

LED



E2 16007
10R-0516079

1200 Lumen

Affectations constructeurs
OE applications
Fahrzeugverwendung
[CHEREAU p.105](#)

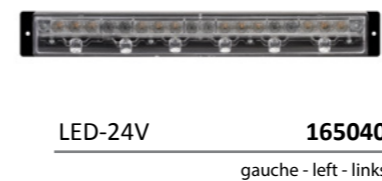

165040 LED-24V
gauche - left - links

Fixation par l'avant
Front fixation
Frontfixierung

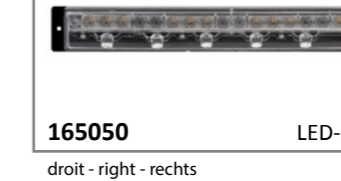

165050 LED-24V
droit - right - rechts



Faisceau p. 276
Harness p. 276
Anschlusskabel siehe S. p. 276

ORIGINAL QUALITY PARTS

ORIGINAL QUALITY PARTS

LA35

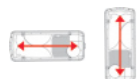

E2 90724

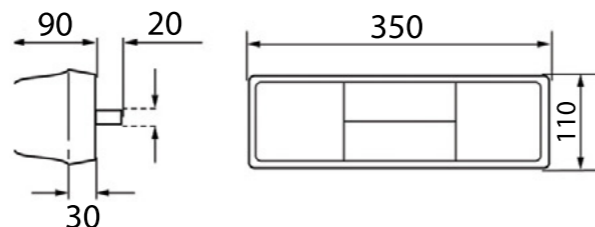

 EPP 135200 gauche - left - links	 PF arrière rear connector Anschlussstecker hinten	 135200 droit - right - rechts
2 x EPP 135300 gauche - left - links		 135300 2 x EPP droit - right - rechts

Pièces détachées - Spare part - Ersatzteile

 EPP 035000 gauche - left - links	 035000 droit - right - rechts
2 x EPP 035300 gauche - left - links	 035300 2 x EPP droit - right - rechts
 000046	

LA25



E2 92004 (LA25)
 146 (LA25K)
 462 (LA25K)
 521 (LA25K)

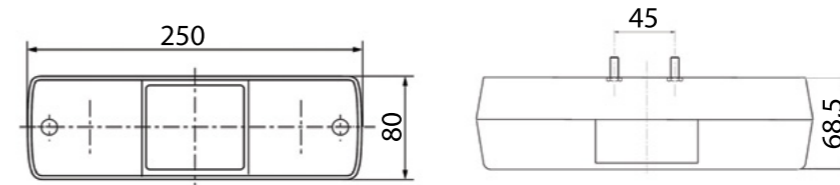

 K 125200 125430 gauche - left - links	 PE arrière rear connector Anschlussstecker hinten	 125200 125430 K droit - right - rechts
EPP 125100 K EPP 125310 gauche - left - links		 125300 EPP 125350 K EPP droit - right - rechts

Pièces détachées - Spare part - Ersatzteile

 K 025200 025210 gauche - left - links	 025200 025210 K droit - right - rechts
EPP 025100 K EPP 025110 gauche - left - links	 025300 EPP 025310 K EPP droit - right - rechts

2711



E3 38553

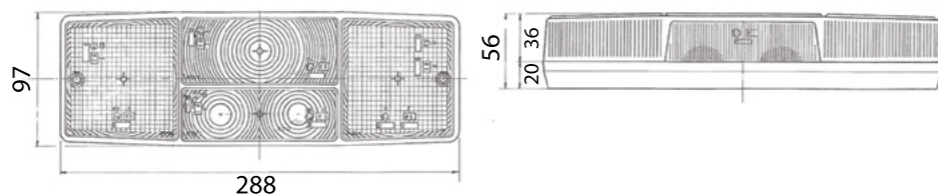

D14523
(27.11.090.VLG)



D14525
(27.11.991.VLG)

gauche - left - links



PE
arrière
rear connector
Anschlussstecker hinten



D14524
(27.11.092.VLG)

D14526
(27.11.992.VLG)

droit - right - rechts



FRR

LED

E4 13992
23271
4052

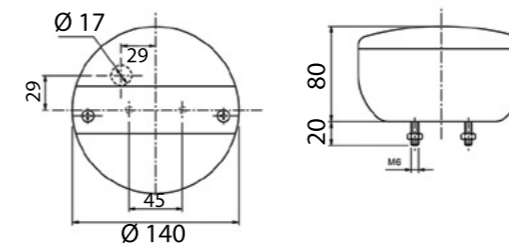

LED-12/24V

D13816

gauche - left - links



PF
arrière
rear connector
Anschlussstecker hinten



D13816

LED-12/24V

droit - right - rechts



D14189

LED-12/24V

feu de recul
reverse lamp
rückfahrleuchte



D14188

LED-12/24V

feu de brouillard
fog lamp
nebelschlussleuchte

FRC

LED

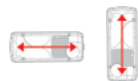

E9 11542
1226
10R-041342
10R-041343

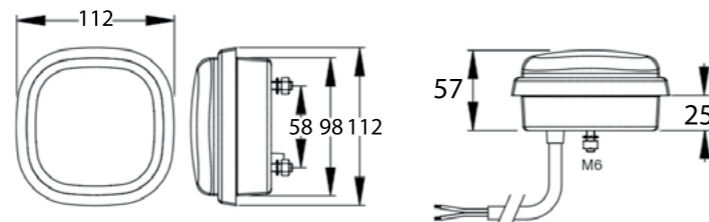

LED-10/30V

D14359

gauche - left - links



PF
arrière
rear connector
Anschlussstecker hinten



D14359

LED-10/30V

droit - right - rechts



D14360

LED-10/30V

feu de recul - brouillard
reverse - fog lamp
rückfahrleuchte - nebelschlussleuchte

FRR

LED

E9 6653
1288
10R-041489
10R-041487

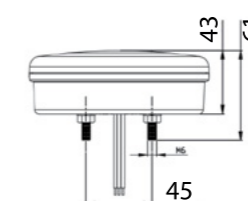
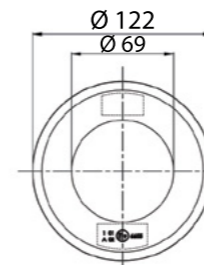

LED-12/24V

D14348

gauche - left - links



PF
arrière
rear connector
Anschlussstecker hinten

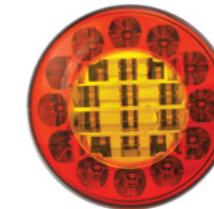

D14348

LED-12/24V

droit - right - rechts

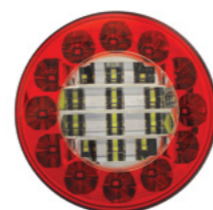

D14345

LED-12/24V

feu de recul - brouillard
reverse - fog lamp
rückfahrleuchte - nebelschlussleuchte

Feux arrière - Rear lamps - Heckleuchten

Feux multifonction - Multifunction lamps - Mehrkammerleuchten

2704

E3 2887

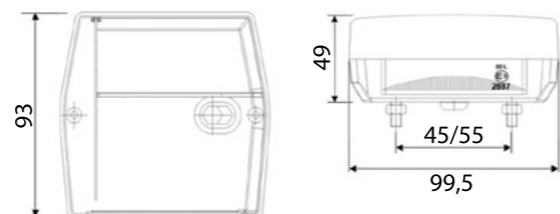

D14518
(27.04.042.VLS) EPP
gauche/droit - left/right - links/rechts



PF
arrière
rear connector
Anschlusstecker hinten



D14527
(27.04.V66.MV7) 7,5 m
valisette 2 feux câblés magnétiques
2 wired lamps magnetic in case
Koffer 2 magnetische Kabel Lichter

Feux arrière - Rear lamps - Heckleuchten

Feux monofonction - Monofunction lamps - Einzelfunktionsleuchten

FM76



E2 136
78

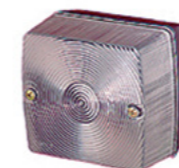
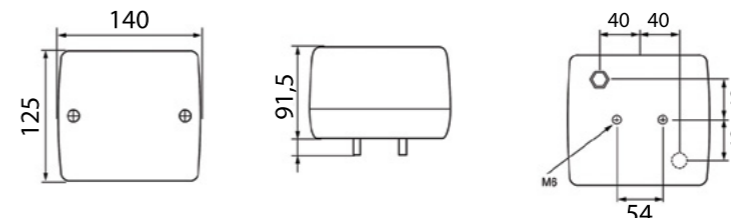

176000 P21W
feu de recul
reverse lamp
rückfahrleuchte



PE
arrière
rear connector
Anschlusstecker hinten



176050 P21W
feu de brouillard
fog lamp
nebelschlussleuchte

C166

E2 113
530
621

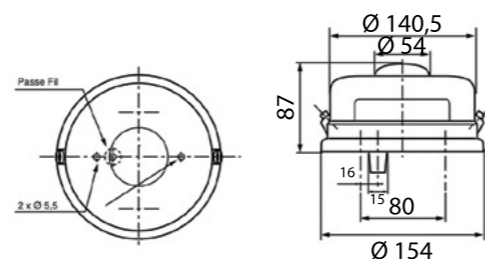

EPP **116600**
gauche - left - links



PF
arrière
rear connector
Anschlusstecker hinten



116600 EPP
droit - right - rechts

Pièces détachées - Spare part - Ersatzteile



EPP **016600**
gauche - left - links



016600 EPP
droit - right - rechts

FRR

E13 697
698

Ø 140 mm x 80 mm



D10840 P21W
feu de recul
reverse lamp
rückfahrleuchte



PF
arrière
rear connector
Anschlusstecker hinten



D10839 P21W
feu de brouillard
fog lamp
nebelschlussleuchte

4030

E2 92025

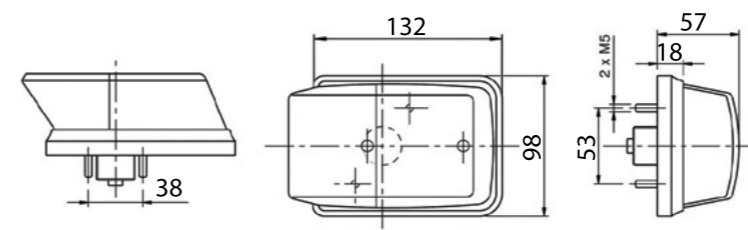

40300225 R5W-P21W
feu de recul
reverse lamp
rückfahrleuchte



40300117 R5W-P21W
feu de brouillard
fog lamp
nebelschlussleuchte

FRR

E13 9657

Ø 140 mm x 80 mm



D10841
gauche - left - links



PF
arrière
rear connector
Anschlusstecker hinten



D10841
droit - right - rechts

Feux arrière - Rear lamps - Heckleuchten

Eclaireurs de plaque - Number plate lamps - Kennzeichenleuchten

2751



E3 2617

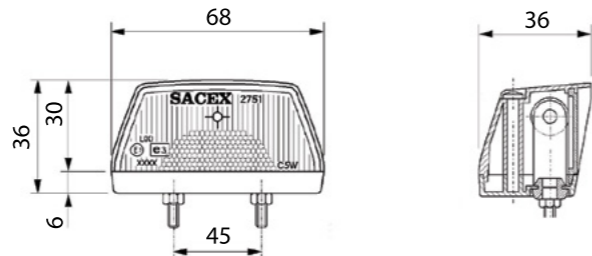

D14517
(27.51.090.VLG) P21W

BX868

E11 4249

E13 10989

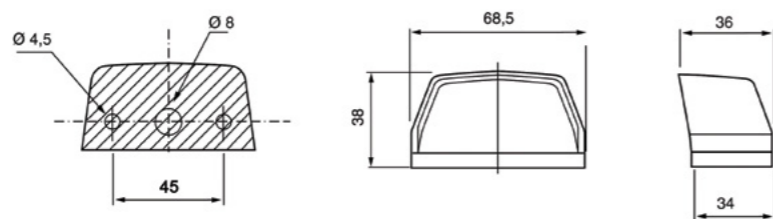

610091 C5W



D14116 LED-12/24V
300 mm

LED

EPP96
LED

LED

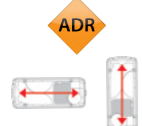

E2 11017

Affectations constructeurs
OE applications
Fahrzeugverwendung
p. 89

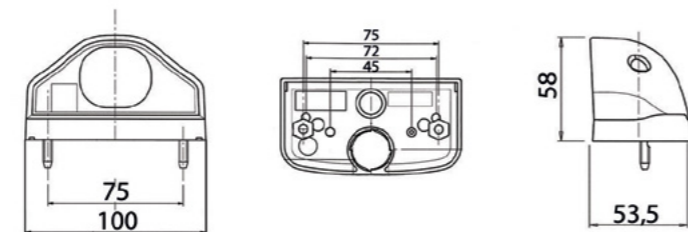

D13609 LED-24V
400 mm
D13610 1500 mm

New



R14364 LED-24V
2000 mm

2V Superseal
Pour / For / Für LC12T

AP Autoperforant pour câble plat
Click-in for flat cable
Click-in Anschluss für Flachkabel

Feux arrière - Rear lamps - Heckleuchten

Eclaireurs de plaque - Number plate lamps - Kennzeichenleuchten

EPP96

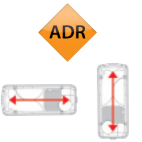

E2 7001

Affectations constructeurs
OE applications
Fahrzeugverwendung
MERCEDES p. 40
RENAULT AGRI p. 44
RENAULT TRUCKS p. 45
p. 89

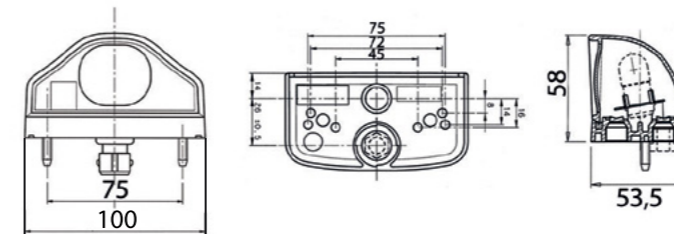

196020 R10W



PE
arrière
rear connector
Anschlussstecker hinten



000176



D10502 R10W
410 mm
D11888 1000 mm



196170 R10W
500 mm

connectique HDSCS - HDSCS connector
HDSCS stecker



D10227 R10W
700 mm

2 voies - 2 poles - 2 polig
Pour / For / Für LC8

EPP98

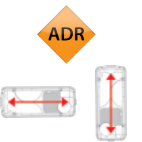

E2 7001

Affectations constructeurs
OE applications
Fahrzeugverwendung
DAF TRUCKSp. 9
OPEL p. 42
RENAULT TRUCKSp. 45
UD TRUCKS p. 78
VOLVO TRUCKSp. 80

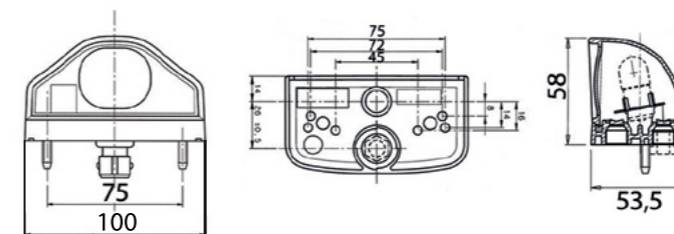

196010 R10W



AMP JPT
arrière
rear connector
Anschlussstecker hinten



Faisceau p. 276
Harness p. 276
Anschlusskabel siehe S. p. 276

AP Autoperforant pour câble plat
Click-in for flat cable
Click-in Anschluss für Flachkabel

Feux clignotants - Flasher lamps - Fahrtrichtungsanzeiger

Face avant - Front face - Frontansicht

C105

E2 06018
12056

Affectations constructeurs
OE applications
Fahrzeugverwendung
[IVECO p. 25](#)

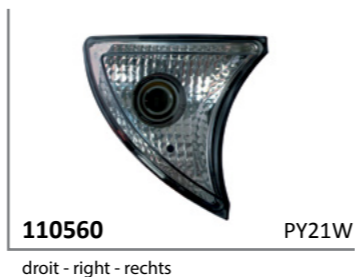
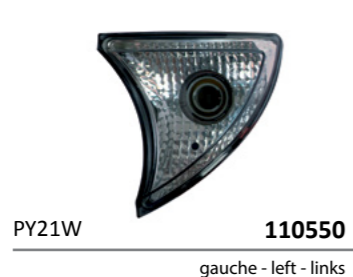
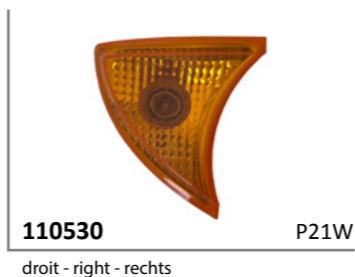
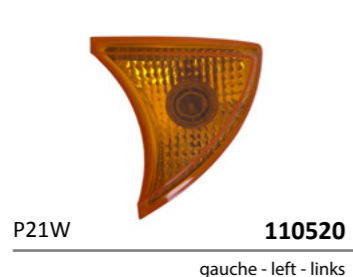

C199

E2 0050

Affectations constructeurs
OE applications
Fahrzeugverwendung
[IVECO p. 25](#)

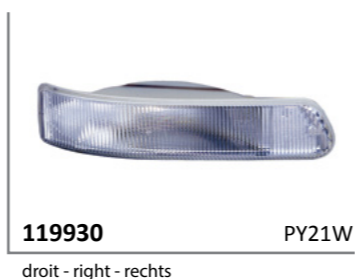
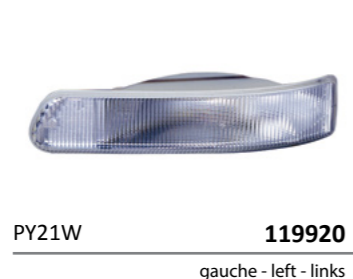

C195

E2 5117

Affectations constructeurs
OE applications
Fahrzeugverwendung
[IRISBUS p. 17](#)



Feux clignotants - Flasher lamps - Fahrtrichtungsanzeiger

Face avant - Front face - Frontansicht

C194

E2 5040

Affectations constructeurs
OE applications
Fahrzeugverwendung
[RENAULT TRUCKS p. 45](#)



* Douille non incluse
* Bulb socket not included
* Glühbirnenfassung nicht mit enthalten



C184

E2 87712

Affectations constructeurs
OE applications
Fahrzeugverwendung
[RENAULT TRUCKS p. 45](#)

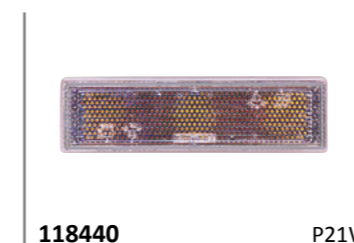

C180

E2 92700

Affectations constructeurs
OE applications
Fahrzeugverwendung
[RENAULT TRUCKS p. 45](#)



C177

E2 91714

Affectations constructeurs
OE applications
Fahrzeugverwendung
[RENAULT TRUCKS p. 45](#)



Feux clignotants - Flasher lamps - Fahrtrichtungsanzeiger

Face avant - Front face - Frontansicht

1085

E2 5060
87002

Affectations constructeurs
OE applications
Fahrzeugverwendung
RENAULT TRUCKS p. 45

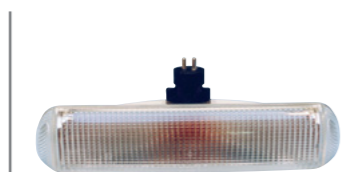

10850605 P21W

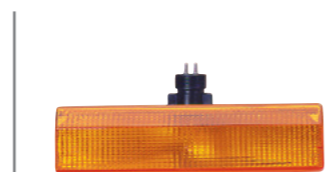

10850603 P21W

BX816

E11 6219

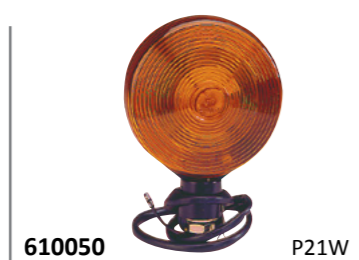
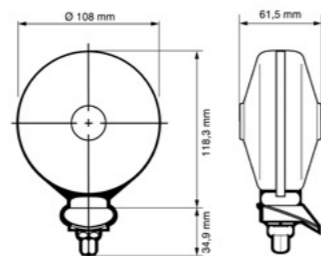

610050 P21W

Feux clignotants - Flasher lamps - Fahrtrichtungsanzeiger

Face latérale - Side face - Seitenansicht

SRD08

LED

E2 10073

Affectations constructeurs
OE applications
Fahrzeugverwendung
VOLVO TRUCKS p. 80



LED-24V 111000

gauche - left - links



111010 LED-24V

droit - right - rechts



LED-24V 111020

gauche - left - links



111030 LED-24V

droit - right - rechts

SRD07

LED

E2 08028

Affectations constructeurs
OE applications
Fahrzeugverwendung
VOLVO TRUCKS p. 80



LED-24V 107000

gauche - left - links



107010 LED-24V

droit - right - rechts



107040

gauche - left - links



107050

droit - right - rechts



New



LED-24V 107500

gauche - left - links



107510 LED-24V

droit - right - rechts

Feux clignotants - Flasher lamps - Fahrtrichtungsanzeiger

Face latérale - Side face - Seitenansicht

ICDL15



E2 16059

Affectations constructeurs
OE applications
Fahrzeugverwendung
UD TRUCKS p. 78



120000 P21W

ICDL10

E2 11128

Affectations constructeurs
OE applications
Fahrzeugverwendung
DAF p. 9



PY21W 117000

gauche - left - links



117010 PY21W

droit - right - rechts

ICDL07

E2 09025

Affectations constructeurs
OE applications
Fahrzeugverwendung
DAF p. 9



109010 P21W

FE85

E2 86708
9033

Affectations constructeurs
OE applications
Fahrzeugverwendung
RENAULT TRUCKS p. 45



185040 R5W



185160 P21W

Feux clignotants - Flasher lamps - Fahrtrichtungsanzeiger

Face latérale - Side face - Seitenansicht

ICDL94

E2 5047 (R5W)
7139 (P21W)

Affectations constructeurs
OE applications
Fahrzeugverwendung

DAF p. 9
HEULIEZ p. 15
IRISBUS p. 17
NISSAN p. 41
RENAULT TRUCKS p. 45
VOLVO TRUCKS p. 80

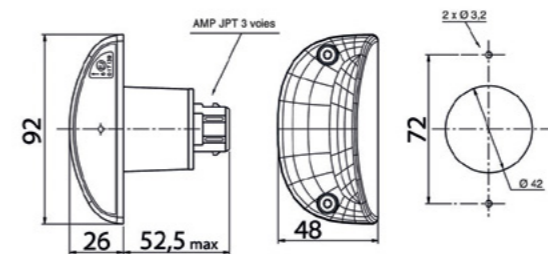

119450 R5W



119470 P21W



119550 P21W



001616



D13877 JPT

connecteur 3 voies JPT
3 poles JPT connector
Anschlussstecker 3 polige JPT

FE87

E2 4703

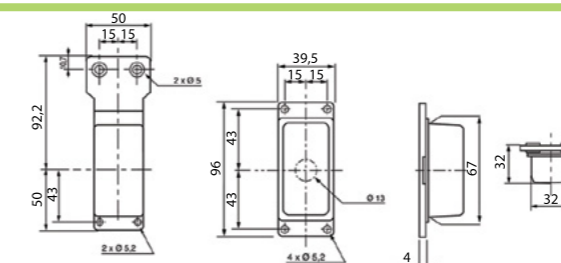

187140 C5W



187760 C5W



178340 C5W



087040

cabochon - lentille - Linse - Linse

Feux clignotants - Flasher lamps - Fahrtrichtungsanzeiger

Face latérale - Side face - Seitenansicht

FE79

E2 3703

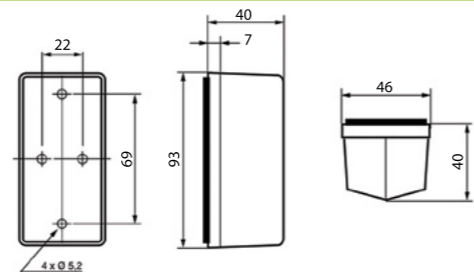

pour presse-étoupe 000176
for o-ring 000176
für PG-Verschraubung 000176



Feux clignotants - Flasher lamps - Fahrtrichtungsanzeiger

Face arrière - Rear face - Heckansicht

0148

E2 87078

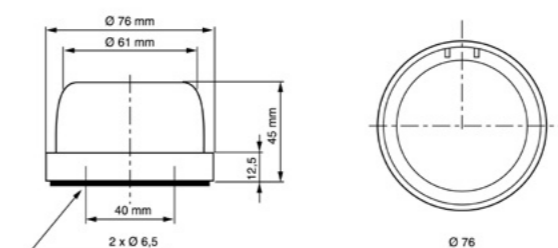

FE81

E2 90711

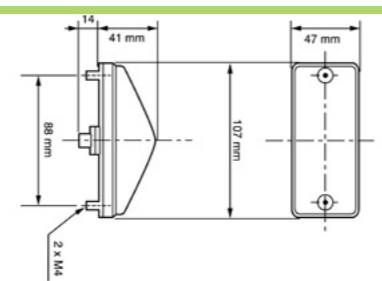

181070 version pétrolière
petroleum version
für Tankfahrzeuge T4W



0207

E2 109
111
112
219

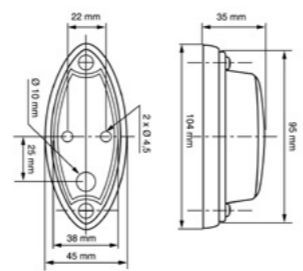

ORIGINAL QUALITY PARTS

ORIGINAL QUALITY PARTS

Feux de position - Position lamps - Positionsleuchten

Face avant - Front face - Frontansicht

FE04

LED

ADR

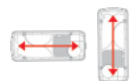

E2 05010 SAE P2

Affectations constructeurs
OE applications
Fahrzeugverwendung
RENAULT TRUCKS p. 45
p. 89

p. 222

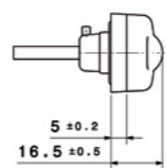
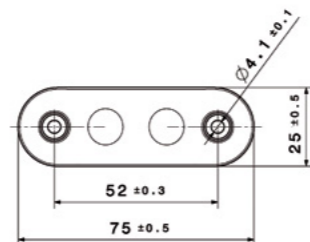

104290	LED-24V 500 mm
104300	1500 mm
104310	5000 mm

D10132	200 mm
--------	--------

104570	LED-24V 300 mm
--------	-------------------

connecteur Deutsch - Deutsch connector - Deutsch Stecker

104450	LED-24V 300 mm
--------	-------------------

connecteur Deutsch - Deutsch connector - Deutsch Stecker

104510	LED-24V 300 mm
--------	-------------------

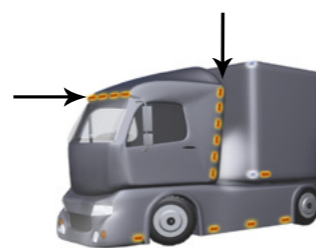

D11268	16 m
--------	------

câble plat - flat cable - flachkabel

Feux de position - Position lamps - Positionsleuchten

Face avant - Front face - Frontansicht

SMD04

LED

ADR



E2 05022

p. 210

p. 222

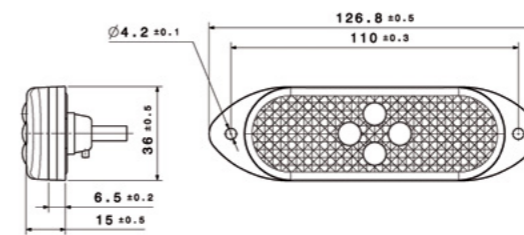

104130	LED-24V 500 mm
104140	1500 mm

104520	LED-24V 1000 mm
--------	--------------------

adhésif - adhesive - selbstklebend

New

104690	LED-24V 1000 mm
--------	--------------------

2V Superseal

SMD98

LED

ADR



E2 04010

p. 211

p. 222

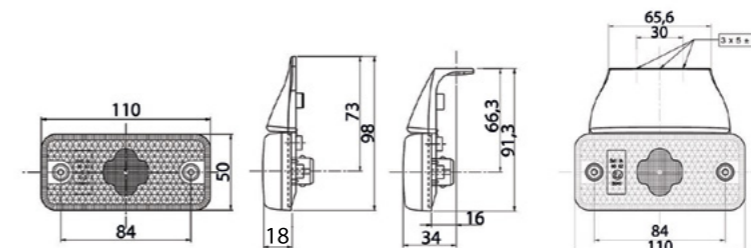

198690	LED-12V
198660	LED-24V

AMP JPT
arrière
rear connector
Anschlussstecker hinten

D10500	LED-24V 500 mm
D11399	1500 mm

D13710	LED-24V 1000 mm
--------	--------------------

2 voies - 2 poles - 2 polig
Pour / For / Für LC8

001696	
--------	--

001716	
--------	--



Faisceau p. 276
Harness p. 276
Anschlusskabel siehe S. p. 276

Catadioptré
Reflector
Rückstrahler

Autoperforant pour câble plat
Click-in for flat cable
Click-in Anschluss für Flachkabel

ORIGINAL QUALITY PARTS

ORIGINAL QUALITY PARTS

Feux de position - Position lamps - Positionsleuchten

Face avant - Front face - Frontansicht

FE94/98

ADR



E2 4088
4089 (K)

p. 213

p. 223

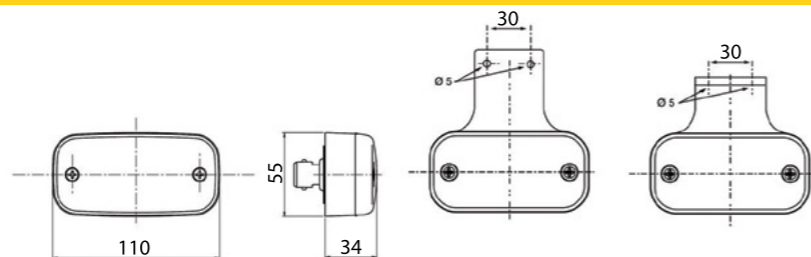

AMP JPT
arrière
rear connector
Anschlussstecker hinten



PE
arrière
rear connector
Anschlussstecker hinten

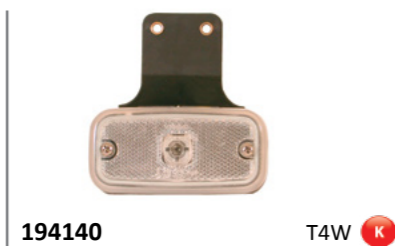

Pièces détachées - Spare part - Ersatzteile

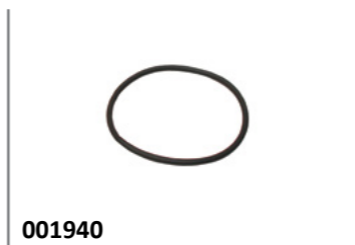

Faisceau p. 276
Harness p. 276
Anschlusskabel siehe S. p. 276

Feux de position - Position lamps - Positionsleuchten

Face avant - Front face - Frontansicht

FE02

ADR



E2 7102

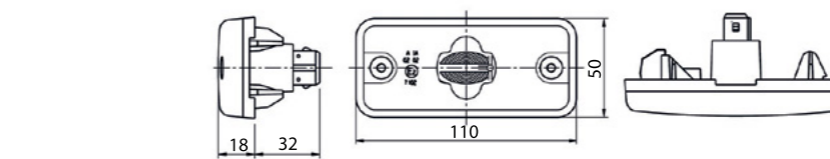

clippé - clipped - clip-befestigung



Faisceau p. 276
Harness p. 276
Anschlusskabel siehe S. p. 276

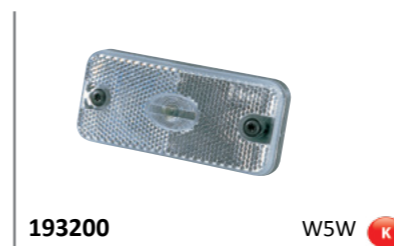
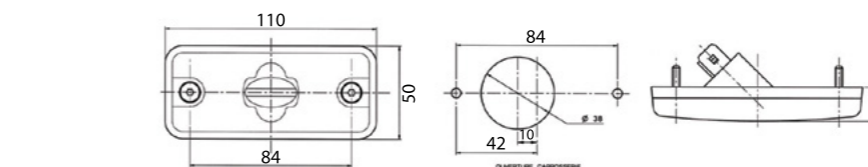

vissé - screwed - geschraubt



ADR



E2 7102

p. 215



Faisceau p. 276
Harness p. 276
Anschlusskabel siehe S. p. 276

FG82

E2 88042

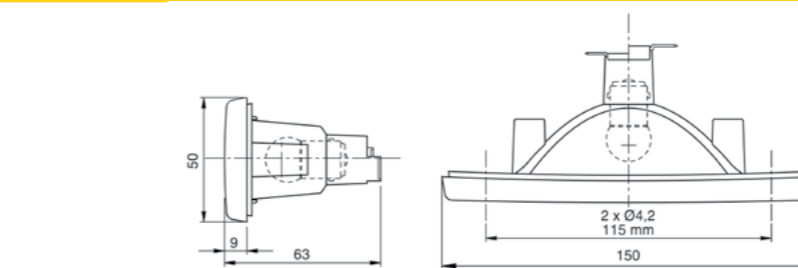

Affectations constructeurs
OE applications
Fahrzeugverwendung
RENAULT TRUCKS p. 45

Feux de position - Position lamps - Positionsleuchten

Face avant - Front face - Frontansicht

FE87

E2 86710

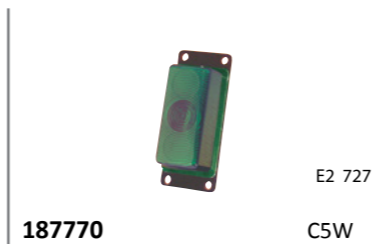
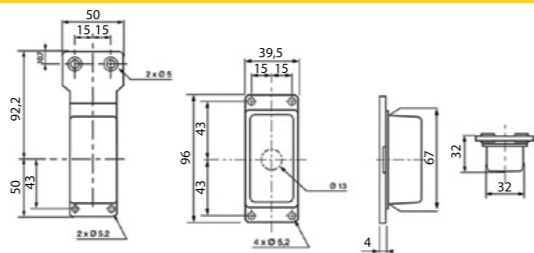

FE79

E2 3704

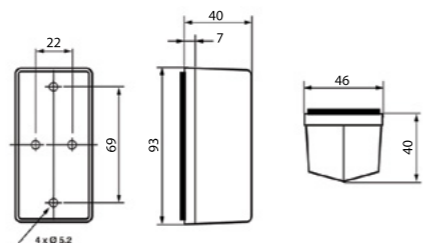

Feux de position - Position lamps - Positionsleuchten

Face avant - Front face - Frontansicht

PLR272

E1 21633

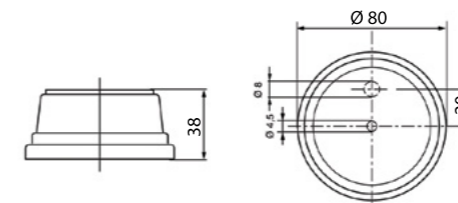

0207

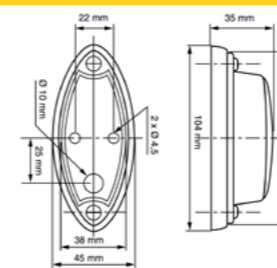

0144

E2 87072

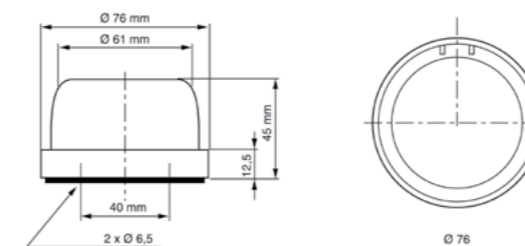

ORIGINAL QUALITY PARTS

ORIGINAL QUALITY PARTS

Feux de position - Position lamps - Positionsleuchten

Face avant - Front face - Frontansicht

FE95

E2 5052

Affectations constructeurs
OE applications
Fahrzeugverwendung

HEULIEZ p. 15
IRISBUS p. 17
RENAULT TRUCKS p. 45
VOLVO TRUCKS p. 80

140 mm x 65 mm x 30,5 mm



195010 W5W

semelle plate - flat gasket - flache Sockeldichtung



195030 W5W

semelle galbée - curved gasket - gewölbte Sockeldichtung

FE85

E2 9037

Affectations constructeurs
OE applications
Fahrzeugverwendung

HEULIEZ p. 15
IRISBUS p. 17
RENAULT TRUCKS p. 45

175 mm x 68 mm x 52 mm



185010 R5W

semelle galbée - curved gasket - gewölbte Sockeldichtung



185020 R5W

semelle plate - flat gasket - flache Sockeldichtung

FE86

E2 87714

220,5 mm x 72,5 mm x 66 mm



R5W 186030

gauche - left - links



186040 R5W

droit - right - rechts

Feux de position - Position lamps - Positionsleuchten

Face avant - Front face - Frontansicht

FE80

E2 314
915
781

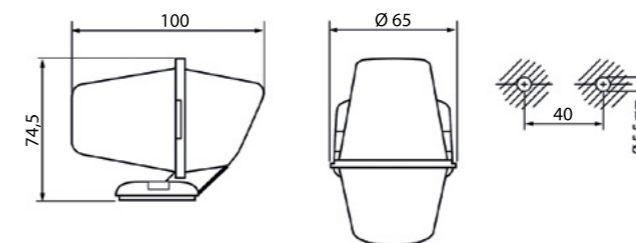

180010 R5W



180220 R5W



180040 R5W



180240 R5W



180050 R5W



180030 R5W

Pièces détachées - Spare part - Ersatzteile



080026



080046

Feux de position - Position lamps - Positionsluchten

Face latérale - Side face - Seitenansicht

SMD04

LED

ADR



E2 05021

p. 203

p. 222

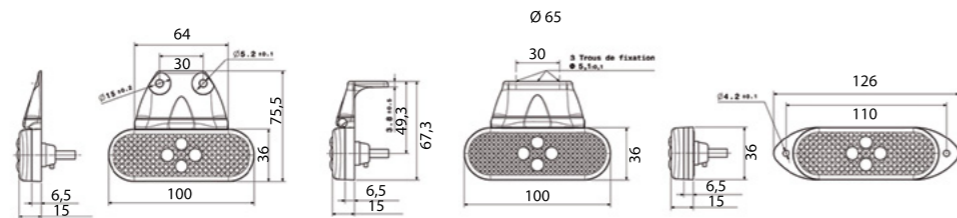

104090 LED-24V 500 mm **K**

104100 LED-24V 1500 mm **K**

104210 LED-24V 500 mm **K**

104220 LED-24V 1500 mm **K**

104250 LED-24V 500 mm **K**

104260 LED-24V 1500 mm **K**

104640 LED-24V 300 mm **K**

104650 LED-24V 1000 mm **K**

D12699 LED-24V 1000 mm **K**

bride rallongée - extended bracket - Montagewinkel verlängerter



104670 LED-24V **K**



104700 LED-24V **K**

104730 LED-24V **K**

104740 LED-24V **K**

002010

Pour / For / Für 104730

002011

Pour / For / Für 104740



Faisceau p. 276
Harness p. 276
Anschlusskabel siehe S. p. 276

Feux de position - Position lamps - Positionsluchten

Face latérale - Side face - Seitenansicht

SMD00

LED

ADR



E2 1295

Affectations constructeurs
OE applications
Fahrzeugverwendung
RENAULT TRUCKSp. 45
VOLVO TRUCKSp. 80

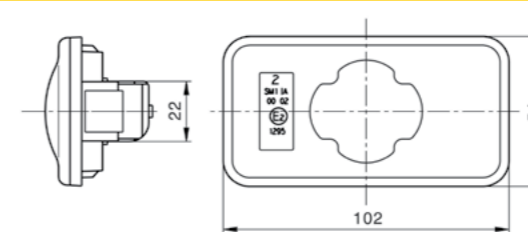

198620 LED-24V **K**

Cuve blanche - cabochon PMMA
White body - PMMA lens
Weißes Gehäuse - PMMA Lichtscheibe

198740 LED-24V **K**

Cuve ambre - cabochon PC haute température
Amber body - PC lens high temperature
Oranges Gehäuse - PC Lichtscheibe hoch temperatur beständig

001766 600 mm

adaptateur - adaptor - Adapterkabel

SMD98

LED

ADR



E2 8040

p. 203

p. 222

Affectations constructeurs
OE applications
Fahrzeugverwendung
IRISBUS p. 17
IVECO p. 25
MANITOWOC p. 38
RENAULT TRUCKS p. 45
VOLVO TRUCKS p. 80

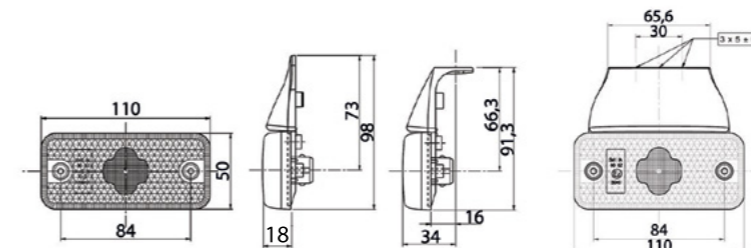

198510 4 x LED-12V **K**

198520 4 x LED-24V **K**



198650 2 x LED-24V **K**

198530 2 x LED-24V **K**

198540 2 x LED-24V **K**

198580 4 x LED-12V **K**

198760 SUPERSEAL 4 x LED-24V **K**



Faisceau p. 276
Harness p. 276
Anschlusskabel siehe S. p. 276

Feux de position - Position lamps - Positionsleuchten

Face latérale - Side face - Seitenansicht

SMD98

LED

ADR



E2 8040

p. 203

p. 222

Affectations constructeurs
OE applications
Fahrzeugverwendung

IRISBUS p. 17
IVECO p. 25
MANITOWOC p. 38
RENAULT TRUCKS p. 45
VOLVO TRUCKS p. 80

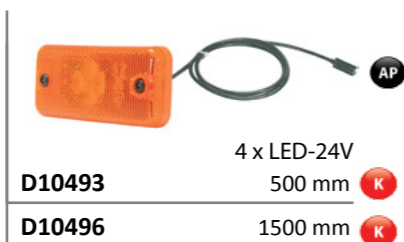
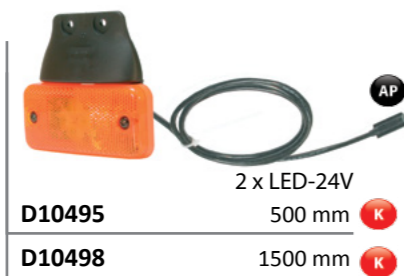
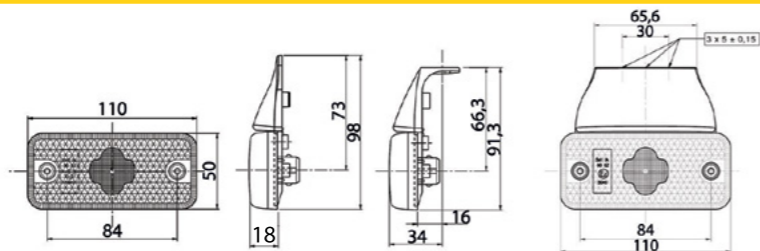

2 voies - 2 poles - 2 polig
Pour / For / Für LC8

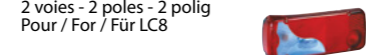

Faisceau p. 276
Harness p. 276
Anschlusskabel siehe S. p. 276

Feux de position - Position lamps - Positionsleuchten

Face latérale - Side face - Seitenansicht

FE94/98

ADR



E2 4092
4093 (K)

p. 204

p. 223

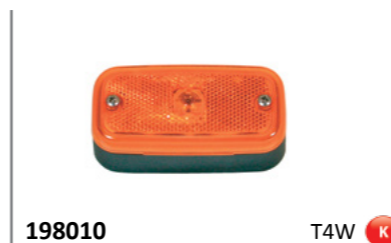
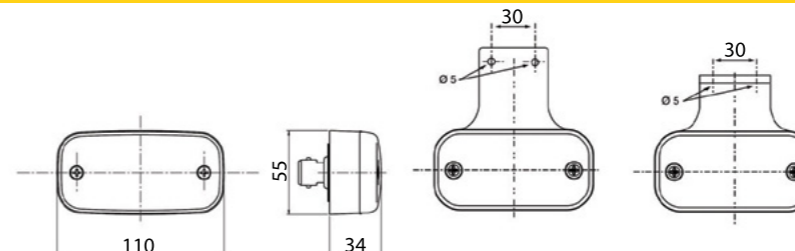

Faisceau p. 276
Harness p. 276
Anschlusskabel siehe S. p. 276

FE94/98

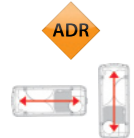

E2 4092
4093 (K)

p. 204

p. 223

Pièces détachées - Spare part - Ersatzteile



094026



094016 K



001596



001586



001696



001716



000176

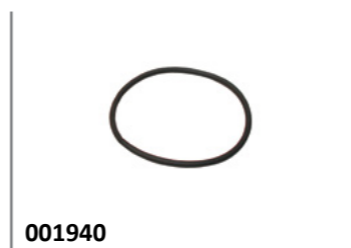

001940

FPL93



E2 4054

p. 205

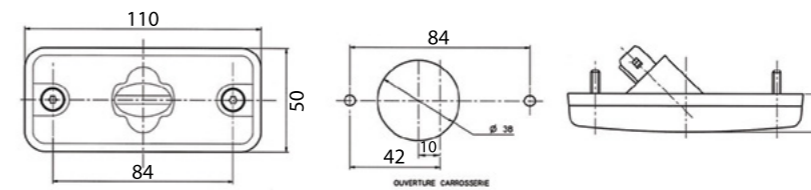

193170

W5W K



193360

W5W K

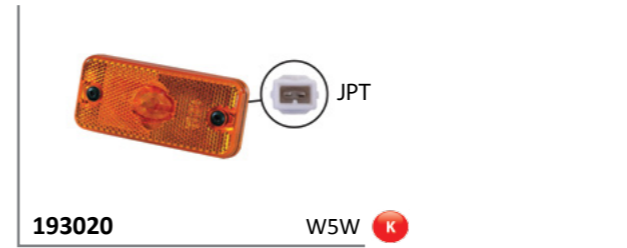

193020

W5W K



193280

W5W K



193290

W5W
380 mm K



001696



001716



001916

SUPERSEAL



001726

JPT



Faisceau p. 276
Harness p. 276
Anschlusskabel siehe S. p. 276

Feux de position - Position lamps - Positionsluchten

Face latérale - Side face - Seitenansicht

672

E9 1084

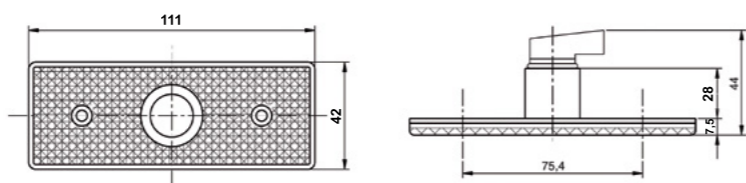

FE87

E2 4701

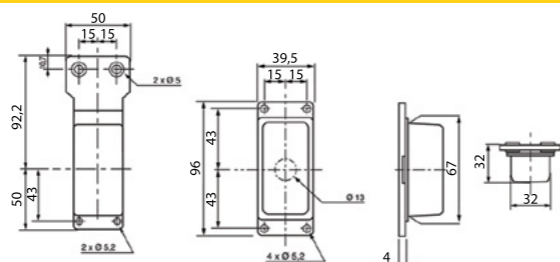

FE81

107 mm x 47 mm x 41 mm



Feux de position - Position lamps - Positionsluchten

Face latérale - Side face - Seitenansicht

FE12

LED

ADR

E24 020078

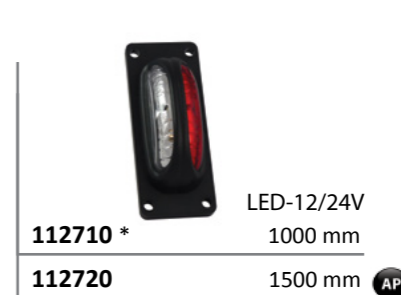
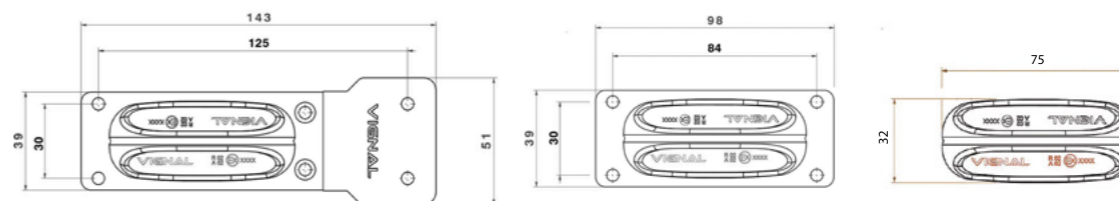

* fils nus - naked cable extremity - Kabellitze

FE88

E2 88714

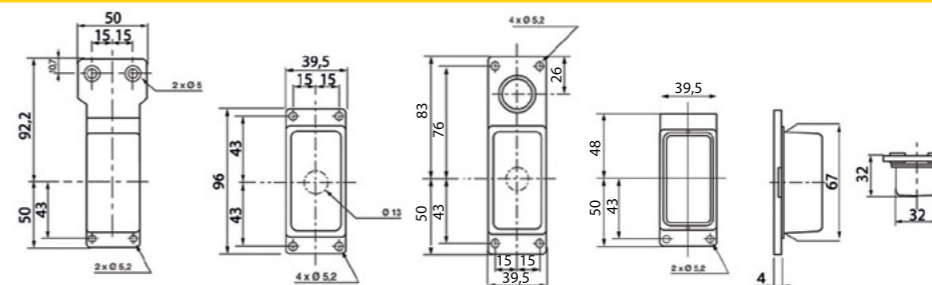

pour presse-étoupe 000176
for o-ring 000176
für PG-Verschraubung 000176



AP Autoperforant pour câble plat
Click-in for flat cable
Click-in Anschluss für Flachkabel

ORIGINAL QUALITY PARTS

ORIGINAL QUALITY PARTS

FE88

E2 88714

Pièces détachées - Spare part - Ersatzteile



088010

cabochon - lens - Lichtscheibe



000176

FE79

E2 4702
92702

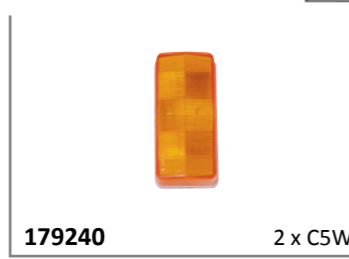
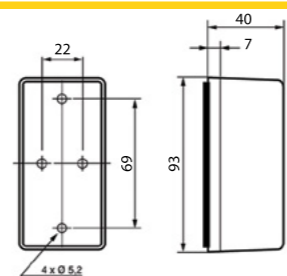

179240

2 x C5W



179340

2 x C5W

pour presse-étoupe 000176
for o-ring 000176
für PG-Verschraubung 000176



179210

2 x C5W



179310

2 x C5W

pour presse-étoupe 000176
for o-ring 000176
für PG-Verschraubung 000176



179350

2 x C5W



000176



079040

cabochon - lens - Lichtscheibe



079010

cabochon - lens - Lichtscheibe

DX LC8

New

LED



LED-12/24V

AP 500 mm

D14038

gauche - left - links



LED

LED-12/24V

D14037

AP 500 mm

droit - right - rechts

ADR

E2 07092



W5W

AP 500 mm

D13034

gauche - left - links



W5W

D13035

AP 500 mm

droit - right - rechts



W5W

350 mm

D12712

gauche - left - links



W5W

D12711

AP 350 mm

droit - right - rechts

DX

ADR

E2 07092



D12430

W5W



D12429

W5W
1500 mm AP



D12471



D12473

K



D12428

W5W
1400 mm AP



D12472

1500 mm AP

K Catadioptré Reflector Rückstrahler

AP Autoperforant pour câble plat Click-in for flat cable Click-in Anschluss für Flachkabel

DX LED

LED

ADR

E2 14010

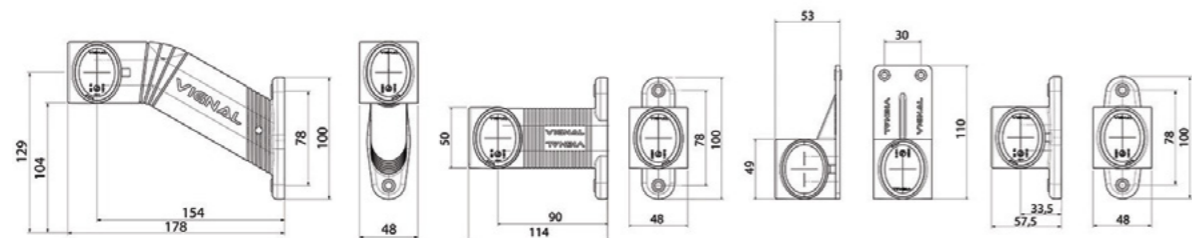

New



LED-12/24V
1700 mm **D14421***

AP 1500 mm **D14427**

gauche - left - links

New



LED-12/24V
1500 mm **D14423**

gauche - left - links

New



LED-12/24V
1500 mm **D14425**

gauche - left - links

New



LED-12/24V
1700 mm **D14431***

AP 1500 mm **D14429**

gauche - left - links



D14031* LED-12/24V
1700 mm

D14035 1500 mm **AP**

symétrique - symmetrical - symmetrisch



2 voies - 2 poles - 2 polig
Pour / For / Für LC8



D14422* LED-12/24V
1700 mm

D14428 1500 mm **AP**

droit - right - rechts



D14424 LED-12/24V
1500 mm

droit - right - rechts



D14426 LED-12/24V
1500 mm

droit - right - rechts



D14432* LED-12/24V
1700 mm

D14430 1500 mm **AP**

droit - right - rechts



D14030* LED-12/24V
1700 mm

D14034 1500 mm **AP**

D13875 1500 mm

symétrique - symmetrical - symmetrisch



* fils nus - naked cable extremity - Kabellitze

AP Autoperforant pour câble plat
Click-in for flat cable
Click-in Anschluss für Flachkabel

DX

ADR

E2 10035

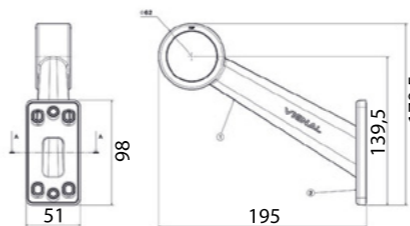

D10642 W5W

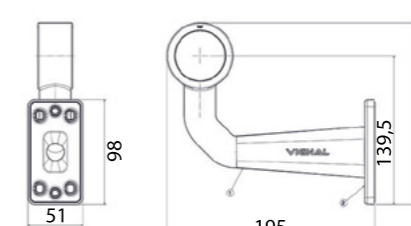

D10643 W5W



D10800 R5W



D10503 600 mm
D11796 1500 mm **AP**



D11797 3000 mm

Pour module de jonction ref. 175020 p. 275
For junction box ref. 175020 p. 275
Für Verteilerdose Art.-Nr. 175020 p. 275



D11899 500 mm

2 voies - 2 poles - 2 polig
Pour / For / Für LC8



D13277 350 mm



610080 R5W



611010 **611020**

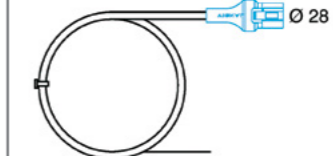

D11147 500 mm



D13624 LED-12/24V

fils nus - naked cable extremity - Kabellitze

LED
E20 020889
020890



Faisceau p. 276
Harness p. 276
Anschlusskabel siehe S. p. 276

AP Autoperforant pour câble plat
Click-in for flat cable
Click-in Anschluss für Flachkabel

Feux de position - Position lamps - Positionsluchten

Face arrière - Rear face - Heckansicht

FE04

LED

ADR



E2 05011

p. 202

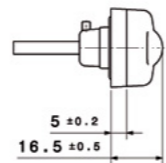
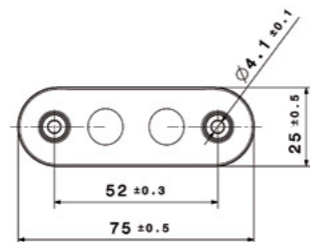

104330	LED-24V	500 mm
104340	LED-24V	1500 mm
104360	LED-24V	5000 mm

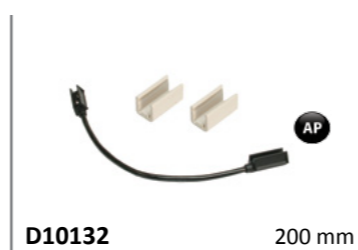

SMD04

LED

ADR



E2 05023

p. 203

p. 210

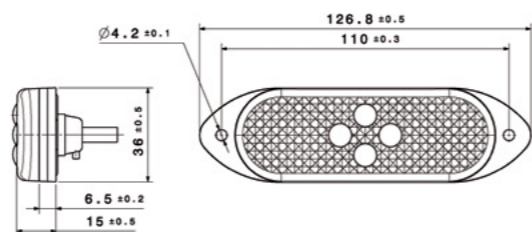

104170	LED-24V	500 mm	K
104180	LED-24V	1500 mm	K



SMD98

LED

ADR



E2 2065

p. 203

p. 211

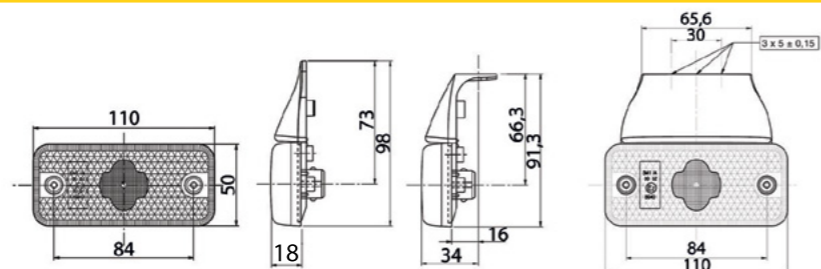

198640	LED-24V	K
---------------	---------	---



D11400	LED-24V	1500 mm	K
D10499	LED-24V	3500 mm	K



Faisceau p. 276
Harness p. 276
Anschlusskabel siehe S. p. 276

Feux de position - Position lamps - Positionsluchten

Face arrière - Rear face - Heckansicht

FE94/98

ADR



E2 4090
4091 (K)

p. 204

p. 213

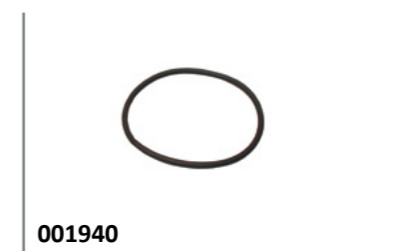
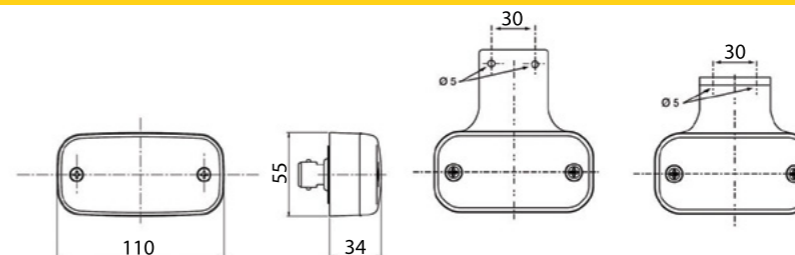

Faisceau p. 276
Harness p. 276
Anschlusskabel siehe S. p. 276

Feux de position - Position lamps - Positionsleuchten

Face arrière - Rear face - Heckansicht

FE87

E2 86711

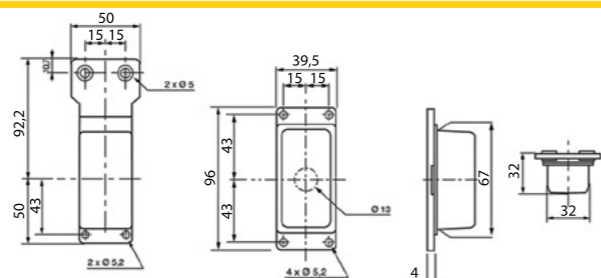

0207

E2 219

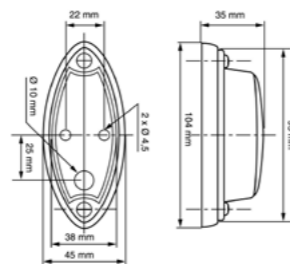

0149

E2 97073

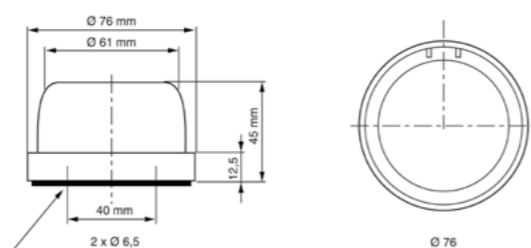

Feux de position - Position lamps - Positionsleuchten

Face arrière - Rear face - Heckansicht

FE95

E2 5126

140 mm x 65 mm x 30,5 mm



Affectations constructeurs
OE applications
Fahrzeugverwendung
[HEULIEZ p. 15](#)
[IRISBUS p. 17](#)

FE85

E2 9036

175 mm x 68 mm x 52 mm



semelle galbée - curved gasket - gewölbte Sockeldichtung



semelle plate - flat gasket - flache Sockeldichtung

ORIGINAL QUALITY PARTS

ORIGINAL QUALITY PARTS



3800 LED

LED

12/24V
22W High Beam
32W Low Beam



E R112 - R6 - R7



POSITION
INDICATEUR DE DIRECTION
AVANT ET ARRIERE
FEUX DE CROISEMENT
FEUX DE ROUTE

POSITION
FRONT AND REAR
DIRECTION INDICATOR
LOW BEAM
HIGH BEAM

POSITION
BLINKER
VORNE UND HINTEN
ABBLENDLICHT
FERNLICHT



12/24V
D14324
(A0831A673200)

gauche - left - links



DT
6 voies - 6 ways - 6 polig



D14325
(A0831A673300) 12/24V

droit - right - rechts



D14352
(A87005182400)

connecteur 6 voies DT
6 poles DT connector
Anschlussstecker 6 polig DT

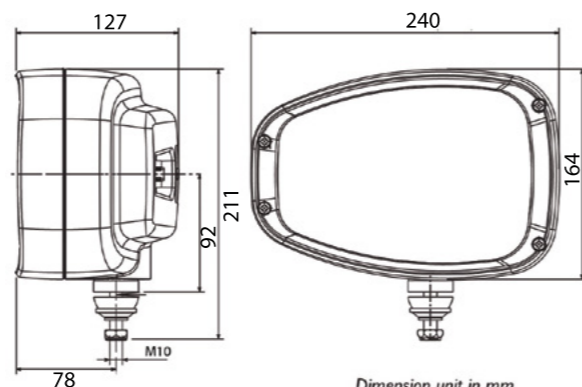

Dimension unit in mm

3800 H4

24V
H4 - PY21 - W5W



E R112 - R6 - R7



12V
D14320
(A0830A673600)
24V
D14322
(A0830A673400)

gauche - left - links



DT
6 voies - 6 ways - 6 polig



D14321
(A0830A673700) 12V
D14323
(A0830A673500) 24V

droit - right - rechts



D14352
(A87005182400)



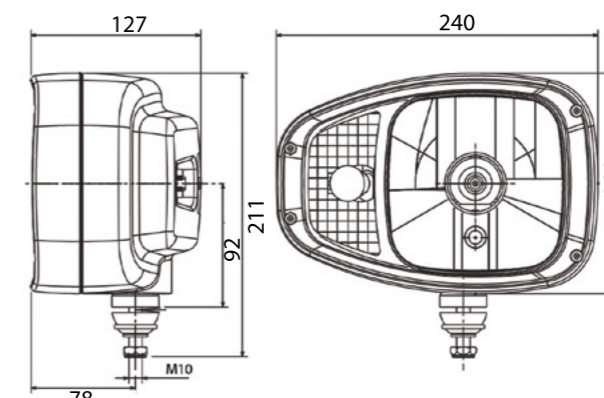

connecteur 6 voies DT
6 poles DT connector
Anschlussstecker 6 polig DT



Dimension unit in mm

SHD 850

LED

-  9/36V
11 W
-  850 Lumen
-  IP69
-  E2 10R-0515046



DT
2 voies - 2 ways - 2 polig

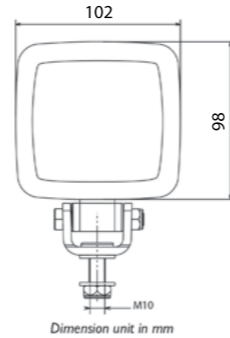
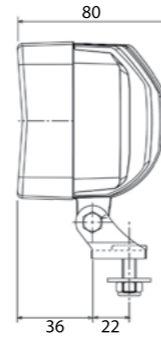



D14160
(A0787A656800) ○

D14295
(A0787A672700) ●

RL 850

LED

-  9/36V
11 W
-  850 Lumen
-  IP69

New



DT
2 voies - 2 ways - 2 polig

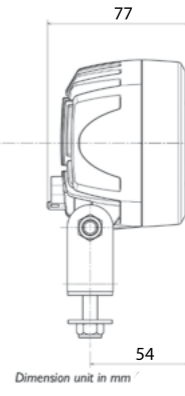
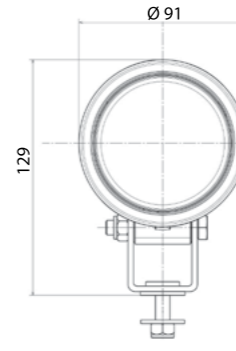

D14386
(A0187A668000) ○

SHD 1200

LED

-  9/36V
11 W
-  1200 Lumen
-  IP69

Affectations constructeurs
OE applications
Fahrzeugverwendung
RENAULT TRUCKS p. 45
VOLVO TRUCKS p. 80



DT
2 voies - 2 ways - 2 polig

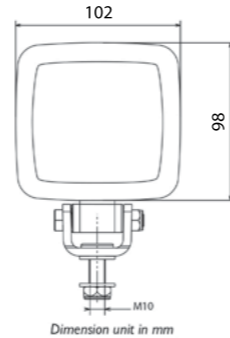
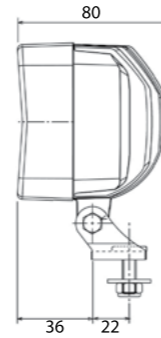

D14161
(A0787A656900) ○

New



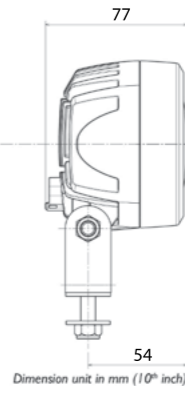
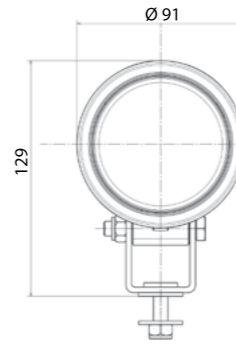

DT
2 voies - 2 ways - 2 polig



D14446
(A0187A682100) ○

SHD 2000

LED

-  12/24-100V
28 W
-  2000 Lumen
-  IP69



DT
2 voies - 2 ways - 2 polig

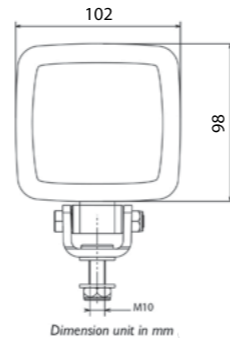
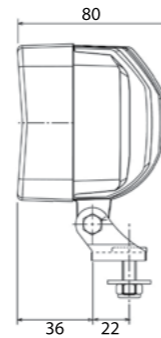

D14162
(A0787A657000) ○

RHD 3000

LED

-  12/24-100V
38 W
-  3000 Lumen
-  IP69



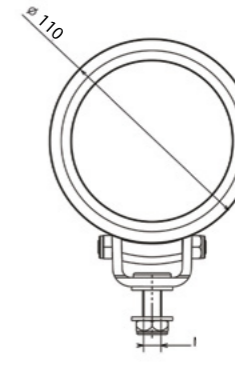
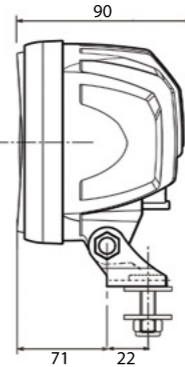

DT
2 voies - 2 ways - 2 polig



D14448
(A0187A682300) ○

SHD 3000

LED

-  12/24-100V
38 W
-  3000 Lumen
-  IP69



DT
2 voies - 2 ways - 2 polig

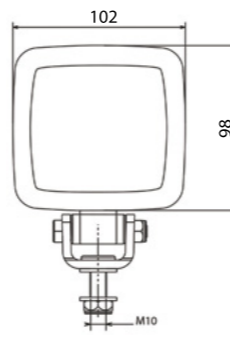
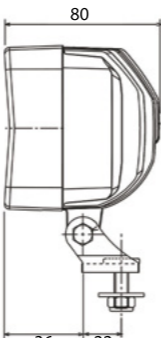

D14447
(A0787A682200) ○

MyLED 2700

LED

- 10/30V
12 W
- 2700 Lumen
- IP69



QR CODE



D14163
(A0690A657100)



DT
2 voies - 2 ways - 2 polig

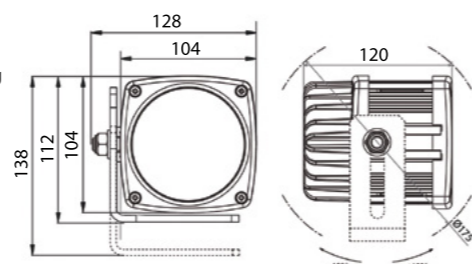

SHD 5000

New

LED

- 12/24-100V
57 W
- 5000 Lumen
- IP69



D14387
(A0727A615900)



DT
2 voies - 2 ways - 2 polig

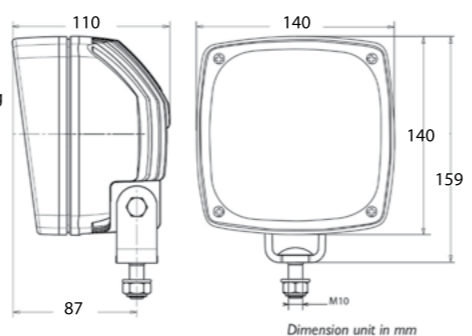

Dimension unit in mm

BL15

New

LED

- 16007
10R-0516079
- 1200 Lumen



Affectations constructeurs
OE applications
Fahrzeugverwendung
CHEREAU p.105



DT04
arrière
rear connector
Anschlusstecker hinten

Fixation par l'arrière
Back fixation
Rückenfixierung



LED-24V 165020
gauche - left - links



165030 LED-24V
droit - right - rechts



LED-24V 165040
gauche - left - links

Fixation par l'avant
Front fixation
Frontfixierung



165050 LED-24V
droit - right - rechts

Faisceau p. 276
Harness p. 276
Anschlusskabel siehe S. p. 276

CARBONLUX

Light - Power - Energy Saving. Licht - Macht Leistung - Energieeinsparung

+ COMPACT - KOMPAKT
LEGER - LIGHT - LEICHT
TECHNO-RESINE CARBONE - TECHNO-RESIN CARBON - KARBONHARZ
OPTIQUE DOUBLE - DOUBLE OPTICS - DOPPELTE OPTIK

2960

LED

- 10/30V
12 W
- 1500 Lumen
- IP69
- E 10R



D14540
(29.60.L00.COV)

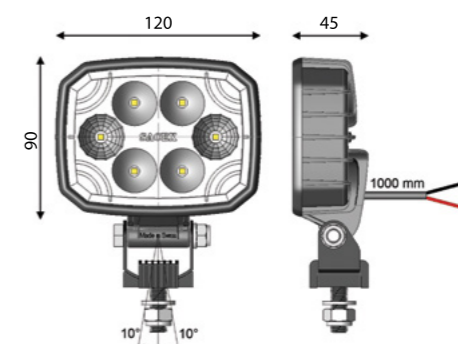

DT
2 voies - 2 ways - 2 polig





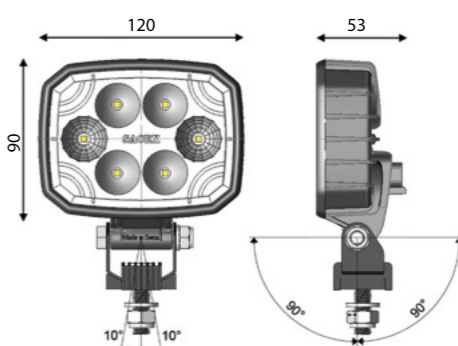

D14541
(29.60.L00.CDV)



2961

LED

-  10/30V
12 W
-  1500 Lumen
-  IP69
-  E 10R

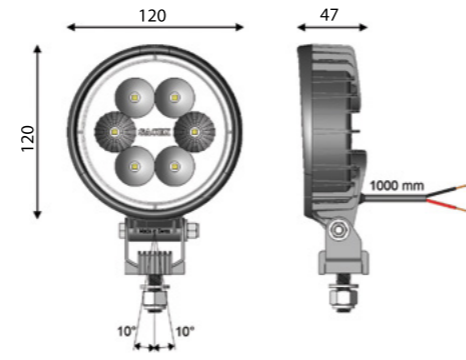



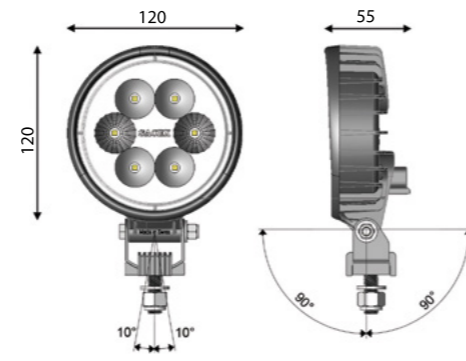

DT
2 voies - 2 ways - 2 polig



2963

LED

-  10/30V
9 W
-  1000 Lumen
-  IP69
-  E 10R

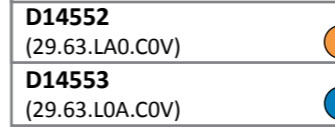
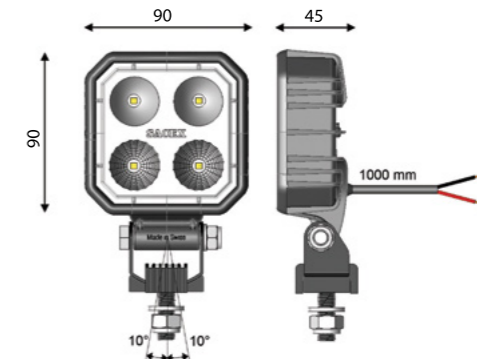

DT
2 voies - 2 ways - 2 polig

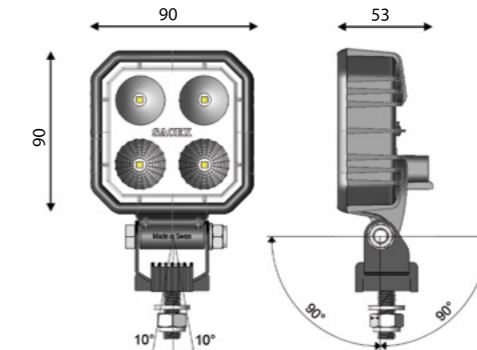

2962

LED

-  10/30V
12 W
-  1500 Lumen
-  IP69
-  E 10R

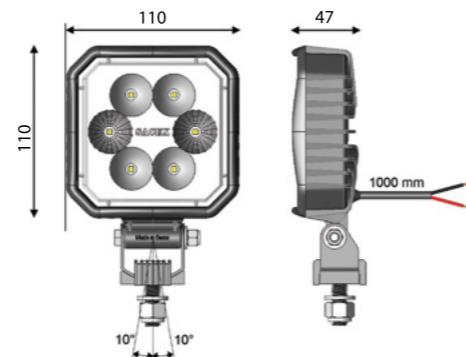

DT
2 voies - 2 ways - 2 polig

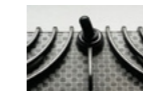
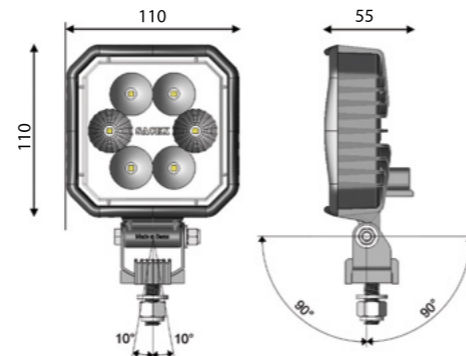

Interrupteur - switch - Schalter

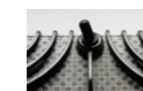
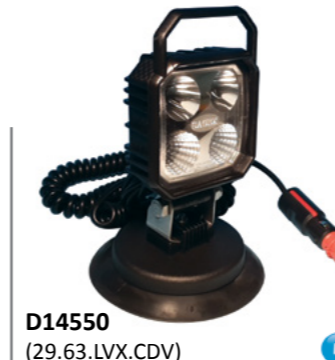

Interrupteur - switch - Schalter



AUTOBLOK

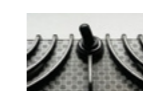

Interrupteur - switch - Schalter



D14170 DT

2 voies DT femelle
Female 2 poles DT connector
Weiblich Anschlussstecker 2 polig





R12486 1500 mm

câble adaptateur DT-CLICK-IN
adapter cable DT-CLICK-IN
Adapterkabel DT-CLICK-IN

2963

LED

-  10/30V
9 W
-  1000 Lumen
-  IP69
-  E 10R
R23

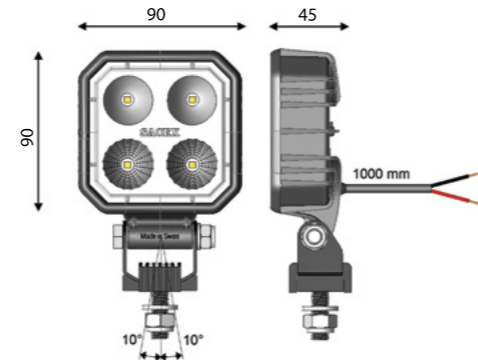

HOMOLOGUÉ REcul
HOMOLOGATED REVERSE
GENEHRÜCKFAHRLUCHE



Interrupteur - switch - Schalter

2990



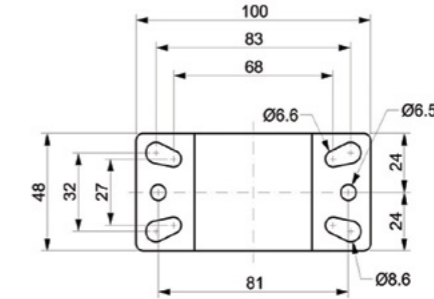
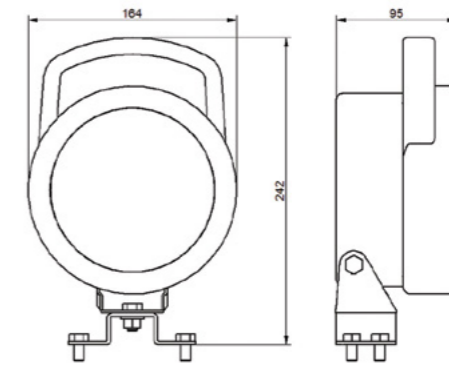

LED

-  10/30V
9 W
-  1500 Lumen
-  IP69
-  E 10R



2964

LED

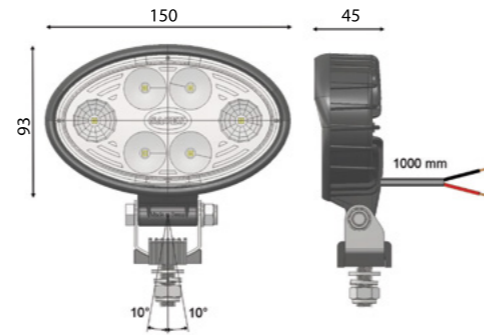

-  10/30V
12 W
-  2000 Lumen
-  IP69
-  E 10R



Interrupteur - switch - Schalter

FTC

LED

-  12/24V
15 W
-  850 Lumen
-  IP67

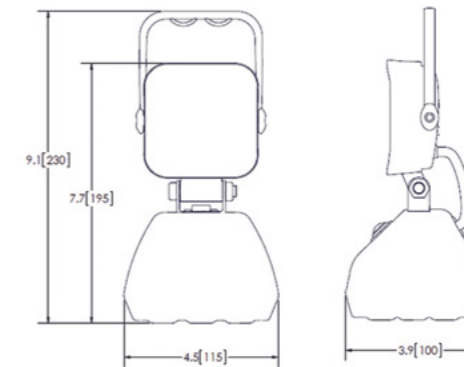

S H3

- H3/70W-24V
H3/35W-24V
- IP54



passe-fil - grommet
einführung mit Tülle

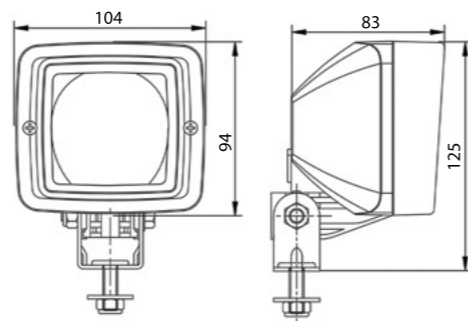

Dimension unit in mm

- D14156**
(A0782A656400)
- D12488***
(A0782A577400)

S H3

- H3/70W-24V
- ADR
- IP69
- E2 R23-07089



DT
2 voies - 2 ways - 2 polig

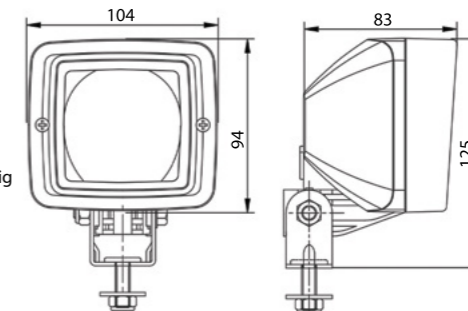

Dimension unit in mm

- D12390***
(2A0782A569100)

Interrupteur - switch - Schalter

Homologué recul - Reverse - Rückfahrleuchte

* lampe fournie - bulb included - inklusiv Glühlampen

S H3

- H3/70W-24V
H3/35W-24V
- IP66

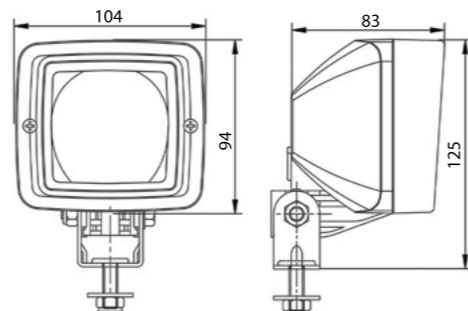

Dimension unit in mm

- D12111***
(A0782A639700)
- D12112***
(A0782A639800)

Affectations constructeurs
OE applications
Fahrzeugverwendung
RENAULT TRUCKS p. 45
VOLVO TRUCKS p. 80

* lampe fournie - bulb included - inklusiv Glühlampen

Q H3

- H3/70W
12/24/36/48/80V
- IP54



passe-fil - grommet
einführung mit Tülle

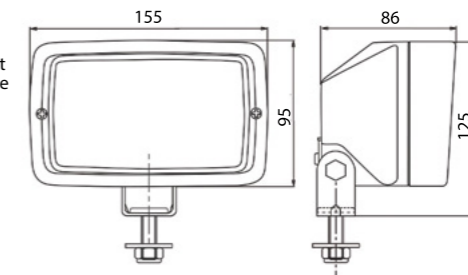

- D14159**
(A0732A656700)

S H3

- H3/70W-24V
H3/35W-24V
- IP66



DT
2 voies - 2 ways - 2 polig



D14170 DT

2 voies DT femelle
Female 2 poles DT connector
Weiblich Anschlussstecker 2 polig

- D13019***
(A0782A563700)
- D13020***
(A0782A563800)

Affectations constructeurs
OE applications
Fahrzeugverwendung
RENAULT TRUCKS p. 45
SCANIA p. 76

* lampe fournie - bulb included - inklusiv Glühlampen

424 H3

- H3/70W
12/24/36/48/80V



passe-fil - grommet
einführung mit Tülle

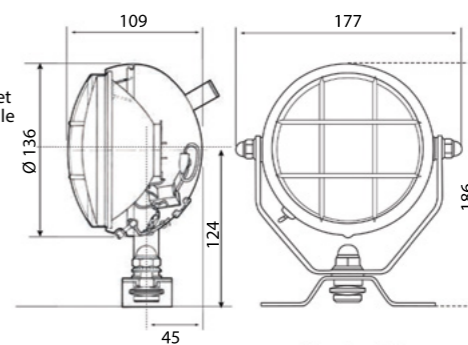

- D14157**
(A0016A656541)

S H3

- H3/70W-24V
- IP66



DT
2 voies - 2 ways - 2 polig

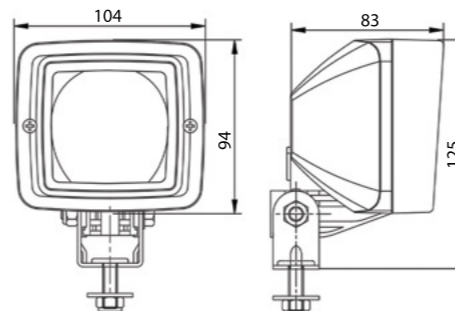

Dimension unit in mm

- D12263***
(A0782A569200)

Interrupteur - switch - Schalter

* lampe fournie - bulb included - inklusiv Glühlampen

824 H3

- H3/70W
12/24/36/48/80V



passe-fil - grommet
einführung mit Tülle

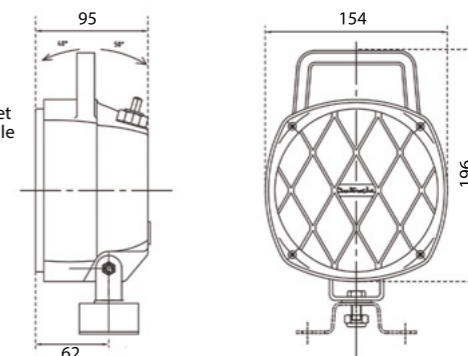

- D14158**
(A0266A656645)

ALPHA 175 LED

LED

⚡ 12/24V
8 W



E2 R7-0214053
R112-0114053

D14167
(A0190A657500)

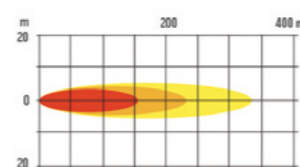
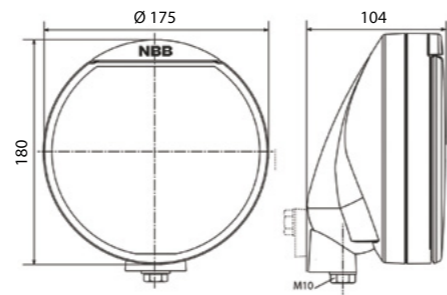

ALPHA 225 PRO XENON

⚡ 35W-D1S GEN5 12/24V
43 W

E2 45-11093

D14164*
(A0301A657282)

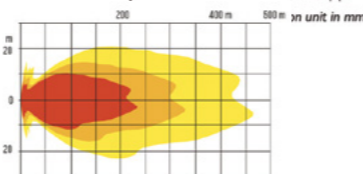
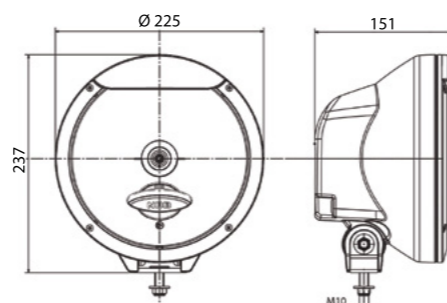

ALPHA 225 XENON

⚡ 35W-D1S GEN5 12/24V
43 W

E4 16903

D14165*
(A0331A657300)

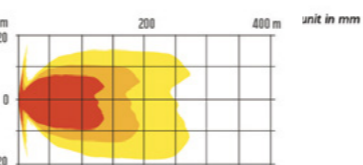
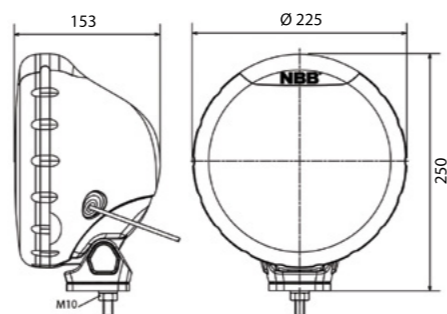

ALPHA 225

⚡ H1-12/24V
70W Max

E4 16902

D14166
(A0330A657400)

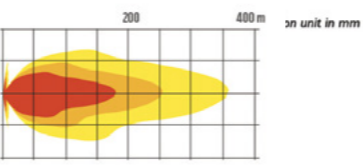
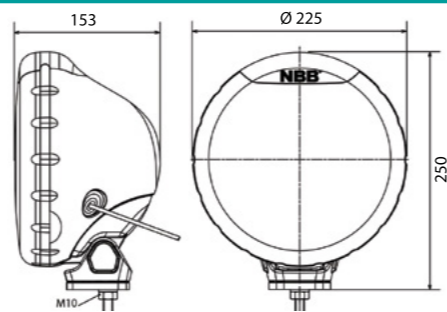

SHD BLUE

LED

⚡ 12/24-100V
5W

💡 1000 Lumen



D14249
(A0787A625500)

D14250
(A0787A625600)

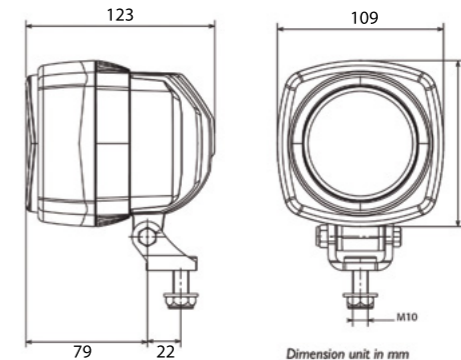

2963

LED

⚡ 10/30V
9W



D14554
(29.63.LSB.C0V)



DT
2 voies - 2 ways - 2 polig

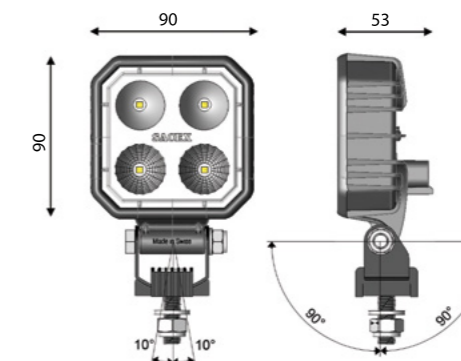

FTC

LED

⚡ 12/24-80V
6W



D14357

D14358

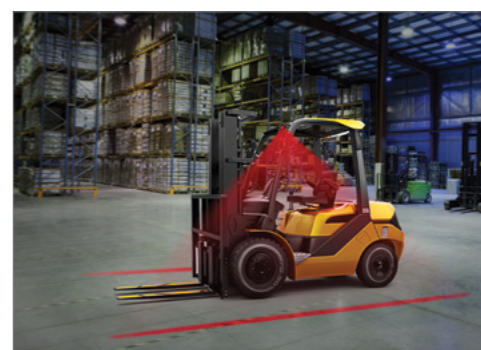
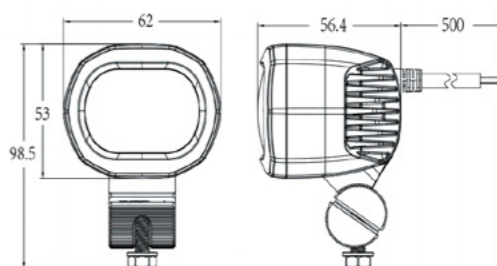

PEGASUS

3 FONCTIONS homologuées ECE R65 : FLASH - DOUBLE FLASH & ROTATIF
 3 FUNCTIONS certified ECE R65 : FLASH - DOUBLE FLASH & ROTATIVE
 3 FUNKTIONEN ECE R65 zugelassen : BLITZLICHT - DOPPELTES BLITZLICHT & RUNDUMLAUF

LED



E R65 - R10



D14501
(21.50.L75.5V8) T

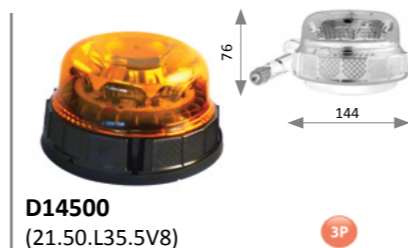

D14500
(21.50.L35.5V8) 3P



D14502
(21.50.LV5.5V8) M

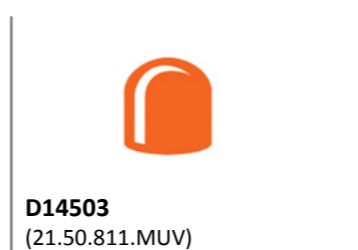

D14503
(21.50.811.MUV)
cabochon - lens - Lichtscheibe

TAURUS

LED



E R65 - R10



D14483
(21.48.L75.3V8) T



D14482
(21.48.L35.3V8) 3P



D14485
(21.48.LV5.3V8) M



D14484
(21.48.LR5.3V8) M

ROLL CABLE



Accessoires p. 251
 Accessories p. 251
 Zubehör S. 251



D14486
(2148.815.RTV)

cabochon - lens - Lichtscheibe



GALAXY

LED



E R65 - R10



D14488
(21.49.L75.3V8) T F

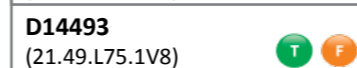

D14493
(21.49.L75.1V8) T F



D14487
(21.49.L35.3V8) 3P F

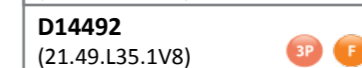

D14492
(21.49.L35.1V8) 3P F

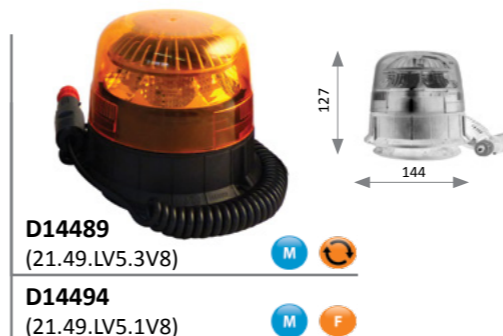

D14489
(21.49.LV5.3V8) M F

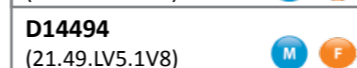

D14494
(21.49.LV5.1V8) M F



D14490
(21.49.LR5.3V8) M F

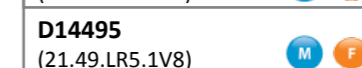

D14495
(21.49.LR5.1V8) M F

ROLL CABLE

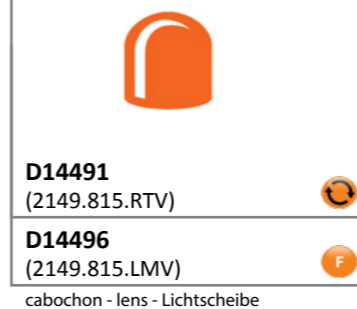

D14491
(2149.815.RTV) F

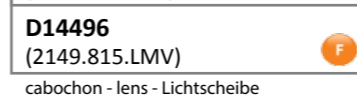

D14496
(2149.815.LMV) F

cabochon - lens - Lichtscheibe

VEGA

LED



E R65 - R10



D14508
(21.87.L75.3V8) T



D14507
(21.87.L35.3V8) 3P

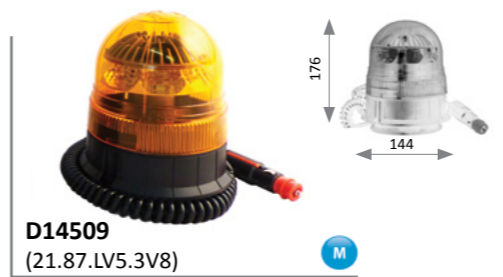

D14509
(21.87.LV5.3V8) M

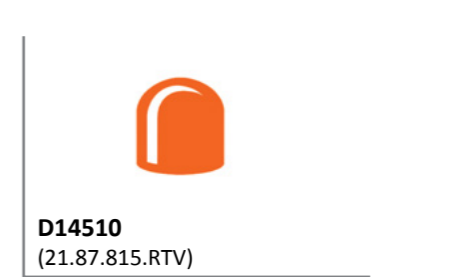

D14510
(21.87.815.RTV)

cabochon - lens - Lichtscheibe

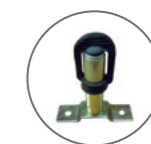

Accessoires p. 251
 Accessories p. 251
 Zubehör S. 251

PUCK

LED



Accessoires p. 251
Accessories p. 251
Zubehör S. 251



COMPACT - KOMPAKT



FRESNEL

LED



VENUS

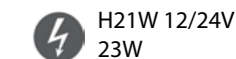

lampes 12/24V fournies - 12/24V bulbs included - inklusiv Glühlampen 12/24V

TAURUS

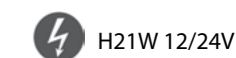

lampes 12/24V fournies - 12/24V bulbs included - inklusiv Glühlampen 12/24V



Accessoires p. 251
Accessories p. 251
Zubehör S. 251

VEGA

H1 - 12/24V



R65 - R10

lampes 12/24V fournies - 12/24V bulbs included - inklusiv Glühlampen 12/24V



Accessoires p. 251
Accessories p. 251
Zubehör S. 251

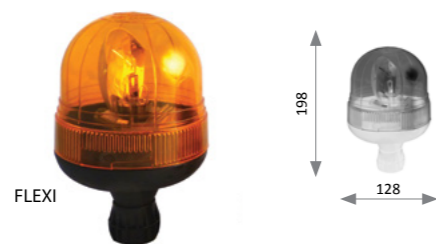

D14479
(21.87.T75.VLG) T



D14477
(21.87.T35.VLG) 3P



D14478
(21.87.TV5.VLG) M



D14480
(21.87.811.VLG)
cabochon - lens - Lichtscheibe

ARIES

H1 - 12/24V



R65 - R10

lampes 12/24V fournies - 12/24V bulbs included - inklusiv Glühlampen 12/24V



D14458
(21.40.T36.VLG) 3P

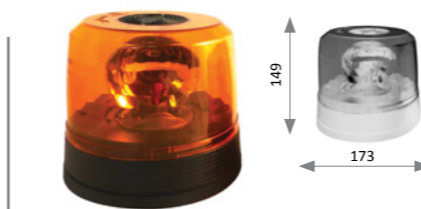

D14460
(21.40.T16.VLG) 1P

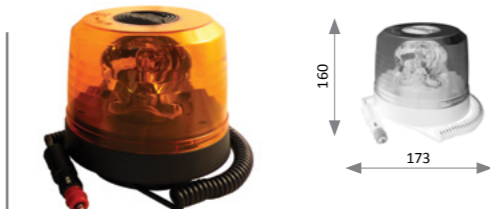

D14459
(21.40.TV6.VLG) M



D14461
(21.40.811.VLG)
cabochon - lens - Lichtscheibe

SATURNE

H1 - 12/24V



R65 - R10

lampes 12/24V fournies - 12/24V bulbs included - inklusiv Glühlampen 12/24V

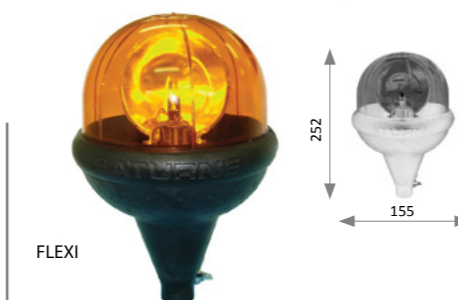

D14475
(21.82.T85.VLG) T



D14476
(21.82.811.VLG)
cabochon - lens - Lichtscheibe

GOUTTE

LED

10/30V
9W



R65 - R10



D14481
(21.35.LMV.358) M

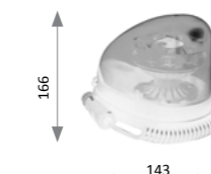

GOUTTE

H1 - 12V



R65 - R10



D14454
(21.35.010.TVL) M



D14455
(21.35.050.TVL) M



D14456
(21.35.811.VLG)
cabochon - lens - Lichtscheibe



D14457
(21.35.851.VLG)
cabochon - lens - Lichtscheibe

MULTILED

3 FONCTIONS homologuées ECE R65 : FLASH - DOUBLE FLASH & ROTATIF
 3 FUNCTIONS certified ECE R65 : FLASH - DOUBLE FLASH & ROTATIVE
 3 FUNKTIONEN ECE R65 zugelassen : BLITZLICHT - DOPPELTES BLITZLICHT & RUNDUMLAUF

LED

10/30V
18W



E R65 - R10

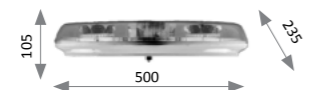

D14504
(23.51.L05.5V8) 1P



D14505
(23.51.LM5.5V8) M



D14506
(23.51.811.VLG)
cabochon - lens - Lichtscheibe

MULTILUX

H1 - 12/24V



E R65 - R10

lampes 12/24V fournies
- 12/24V bulbs included -
inklusive Glühlampen 12/24V

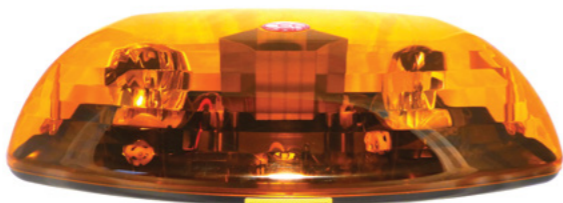

D14472
(2350.03T.PVL) 1P



D14473
(2350.M3T.PVL) M



D14474
(2350.811.VLG)
cabochon - lens - Lichtscheibe

Pièces détachées - Spare part - Ersatzteile



D14511
(21.76.282.VLG)
semelle plate - flat gasket - Flache Sockeldichtung



D14512
(21.76.283.VLG)
semelle inclinée - tilted gasket - Gekippte Sockeldichtung



Exemple de montage - Assembly suggestion -
Montagebeispiel



D14513
(21.91.000.VLG)
tige à visser - socket to be screwed
Aufsteckrohr zum Anschrauben
ISO 4148/4165



D14514
(21.92.000.VLG)
tige avec support central - socket with central clamp - Aufsteckrohr mit zentralem Tragbuegel
ISO 4148/4165

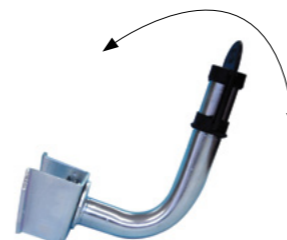

D14515
(21.97.005.VLG)
tige articulée 360° - 360° rotating socket -
Bewegbarer Aufsteckrohr 360°
ISO 4148/4165



D14516
(21.99.000.VLG)
rallonge télescopique pour gyrophares 80/135 cm
Telescopic extension rod 80/135 cm for beacons
Teleskop. verlaengerung fur Rundumk. 80/135 cm
ISO 4148/4165



D14565 H21W 12V BAY9s
(90.16.025.VLG)



D14566 H21W 24V BAY9s
(90.16.026.VLG)

DIR

LED

12/24V
4,8 W



E R10

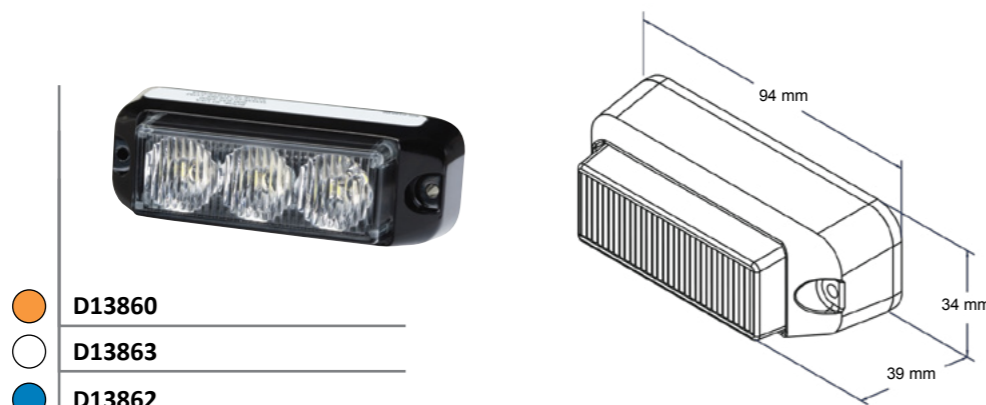

- **D13860**
- **D13863**
- **D13862**

11 types de flash
11 flash patterns
11 Blitzmuster

DIR

LED

12/24V
18 W



E R65 - R10

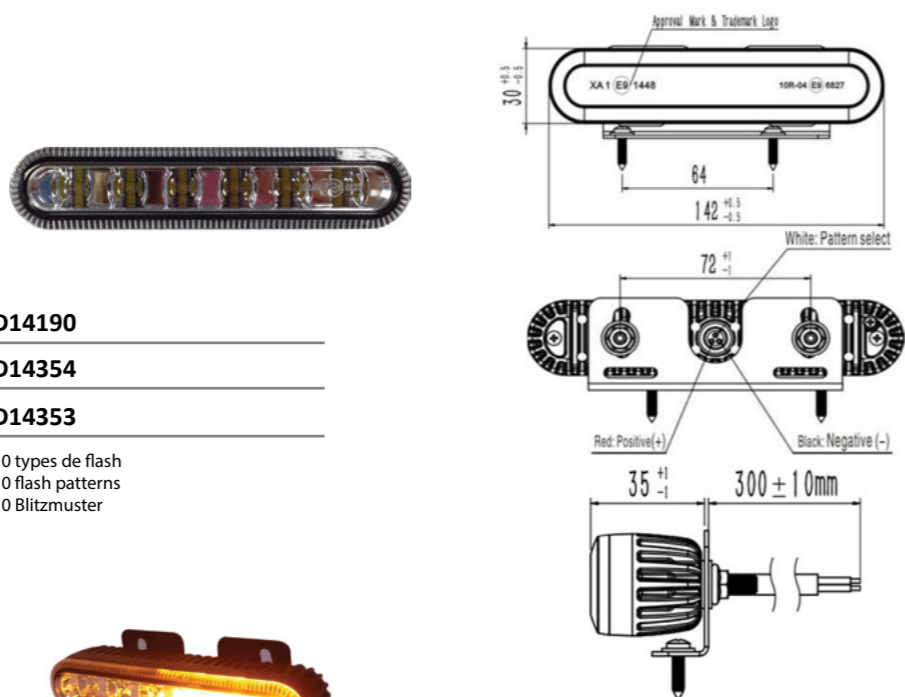

- **D14190**
- **D14354**
- **D14353**

10 types de flash
10 flash patterns
10 Blitzmuster



Alternative flash

ASR

101 mm x 67 mm x 41 mm



1	630120	12/24V 87 db
2	630110	82-102 db
3	630100	102 db

102 mm x 71 mm x 41 mm



D13807	12/24V 87 db
D13808	97 db



D13810	12/24V 97 db 1500 mm
---------------	----------------------------



001830
24V
90 db

Pour connection sur feu arrière LC8 p. 162
To plug in LC8 rear lamp p. 162
Zum direkten Anschluss an die Heckleuchte LC8 S. p. 162



001872
24V
55-90db

Ajustement bruit ambiant sur feu arrière LC8 MAN p. 162
Environment noise adjustment MAN LC8 rear lamp p. 162
Automatische Umgebungslärm Heckleuchte MAN LC8 S. p. 162



D12953
24V
90 db

Pour connection sur feu arrière LC9 p. 159, LC7 p. 174
To plug in LC9 / LC7 rear lamp p. 159 / p. 174
Zum direkten Anschluss an die Heckleuchte LC9 S. p. 159, LC7 S. p. 174



D14210
5V

Capteur - Sensor



D14211
24V
108 db

Son continu pour système spécifique
Continuous sound for specific system
Dauerton für Spezialanwendungen

Kit SANS FIL digital - Digital wireless kit - Digital Drahtlos-Satz kit



D14328 12/24V

12/24V - Ecran fractionné couleur 7 pouces - transmission sans fil 2.4 GHz - Raccordement jusqu'à 4 caméras - **appairage automatique** - **Enregistrement en temps réel** - **Support carte micro SD non fournie** - Caméra micro intégré - vision de nuit - Utilisation entre -20°C et +60°C



12/24V - 7 inch colour quad screen - Wireless transmission 2.4 GHz - connecting up to 4 wireless cameras - **Auto scan** - **Real time recording** - **Support SD card** - Camera with micro integrated - night vision - Use between -20°C and +60°C

12/24V - 7" Farbbildschirm - Übertragungsfrequenz 2,4 GHz - bis zu 4 drahtlose Kameras und eine mit Kabel anschließbar - **Automatischer Abgleich** - **Echtzeitaufnahme** - **SD Karten Aufnahme** - Nachtsichtkamera mit integriertem Mikrofon - Betriebstemperatur -20°C bis +60°C



D14196 12/24V

12/24V - Ecran fractionné couleur 7 pouces - transmission sans fil 2.4 GHz - **appairage automatique** - **Enregistrement en temps réel** - **Support carte micro SD non fournie** - Caméra micro intégré - vision de nuit - Utilisation entre -20°C et +60°C



12/24V - 7 inch colour quad screen - Wireless transmission 2.4 GHz - **Auto scan** - **Real time recording** - **Support SD card** - Camera with micro integrated - night vision - Use between -20°C and +60°C

12/24V - 7" Farbbildschirm - Übertragungsfrequenz 2,4 GHz - **Automatischer Abgleich** - **Echtzeitaufnahme** - **SD Karten Aufnahme** - Nachtsichtkamera mit integriertem Mikrofon - Betriebstemperatur -20°C bis +60°C

Pièces détachées - Spare part - Ersatzteile



D14236 12/24V



D14216 12/24V

Ecran 7" - 7" screen - 7" Farbbildschirm
Fractionnable - Multi display - Teilbar



D14063



D14326



D14347 10/32V M

Batterie mobile - 10-12h autonomie
Mobile battery - 10-12h autonomy
Mobilbatterie - 10-12h autonomie

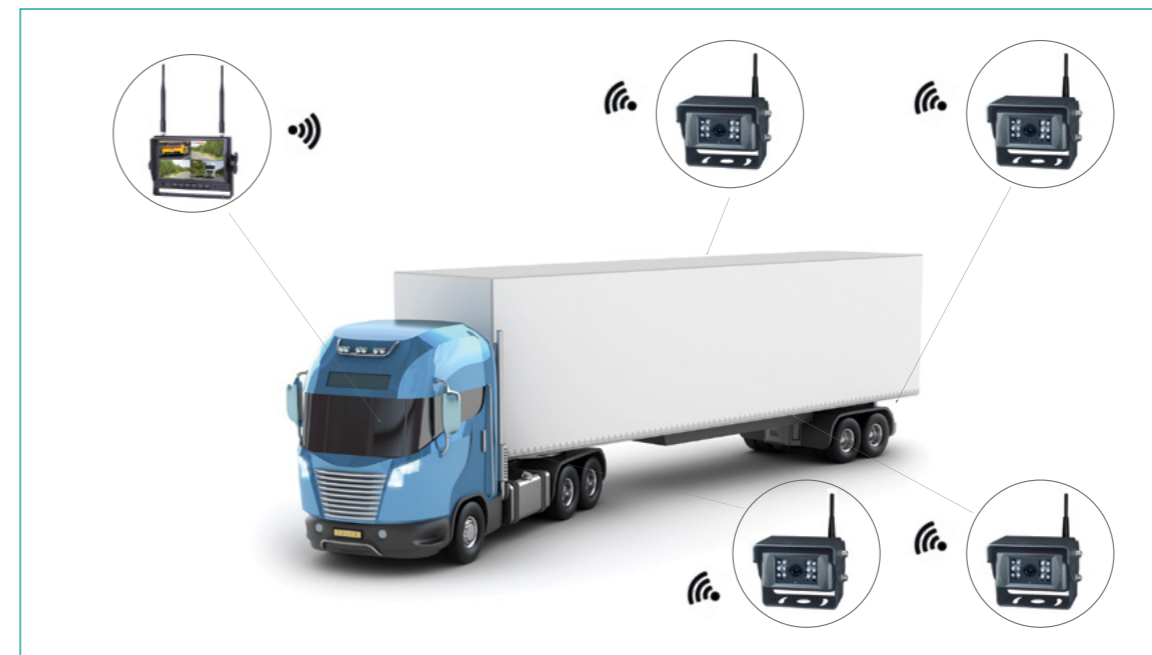

Exemple de montage - Assembly suggestion - Montagebeispiel
Kit D14196



Les appareils 2.4 GHz tels que les téléphones cellulaires, les systèmes Bluetooth et Wi-Fi peuvent causer des interférences passagères.
2.4 GHz devices such as mobile phones, Bluetooth and Wi-Fi may cause some temporary interferences.
Bei gleichzeitigem Betrieb von Geräten, die im Frequenzbereich von 2,4 GHz arbeiten, wie z.B. Mobiltelefone, Bluetooth und WLAN Übertragungen, können gelegentlich Störinterferenzen auftreten.

Kit filaire - Wired rear view systems - Verdrahtet-Satz kit

ENVIRONNEMENT SEVERE
HARSH ENVIRONMENT
EXTREME UMWELTBEDINGUNGEN



A10091 12/24V

12/24V - Ecran couleur 7 pouces - Raccordement jusqu'à 3 caméras - Caméra LED en aluminium micro intégré - vision de nuit - Utilisation entre -40°C et +70°C



12/24V - 7 inch colour screen - Connecting up to 3 cameras - LED aluminium camera with micro integrated - night vision - Use between -40°C and +70°C

12/24V - 7" Farbbildschirm - bis zu 3 Kameras anschließbar - LED - Nachtsichtkamera aus Aluminium mit integriertem Mikrofon - Betriebstemperatur -40°C bis +70°C



D13494 12/24V

12/24V - Ecran couleur 5 pouces - Raccordement jusqu'à 3 caméras - Caméra LED micro intégré - vision de nuit - Utilisation entre -10°C et +65°C



12/24V - 5 inch colour screen - Connecting up to 3 cameras - LED camera with micro integrated - night vision - Use between -10°C and +65°C

12/24V - 5" Farbbildschirm - bis zu 3 Kameras anschließbar - LED - Nachtsichtkamera mit integriertem Mikrofon - Betriebstemperatur -10°C bis +65°C

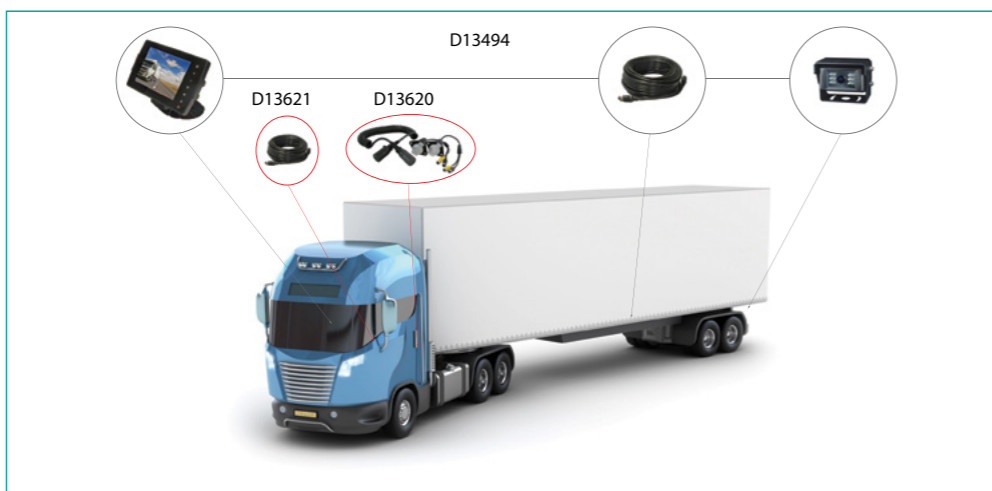

Exemple de montage - Assembly suggestion - Montagebeispiel
Kit D13494 + D13621 + D13620



D13616 12/24V

12/24V - Ecran couleur 7 pouces fractionnable - Caméra arrière LED micro intégré - vision de nuit - Caméras latérales (synchro indicateur de direction) - Caméra avant grand angle - Utilisation entre -20°C et +50°C



12/24V - 7 inch multi-display colour screen - LED camera with micro integrated - night vision - Side cameras (synchro side repeater) - Front camera wide angle - Use between -20°C and +50°C

12/24V - 7 Zoll LCD Fahrbildschirm (teilbar) - LED Nachtsichtkamera mit Mikrofon - Seitenkameras (synchronisiert mit Fahrtrichtungsanzeiger) - Weitwinkel-Frontsichtkamera - Betriebstemperatur -20°C bis +50°C



D14329 12/24V

12/24V - Ecran couleur 5 pouces - Raccordement jusqu'à 3 caméras - Caméra LED SLIM - vision de nuit - Utilisation entre -20°C et +70°C



12/24V - 5 inch colour screen - Connecting up to 3 cameras - SLIM LED camera - night vision - Use between -20°C and +70°C

12/24V - 5" Farbbildschirm - bis zu 3 Kameras anschließbar - LED - Nachtsichtkamera SLIM - Betriebstemperatur -20°C bis +70°C

IDEAL VUL
IDEAL LCV
IDEALES NFZ



Pièces détachées
Spare part
Ersatzteile



Composez votre kit sur-mesure
Build your own custom kit
Stellen Sie sich Ihr Kit maßgeschneidert zusammen

1. Ecran - Monitor - Farbbildschirm



D13497 12/24V
Ecran 5" - 5" screen - 5" Farbbildschirm



D13887 12/24V
Ecran 7" - 7" screen - 7" Farbbildschirm



D13501 12/24V
Ecran 7" - 7" screen - 7" Farbbildschirm
Fractionnable - Multi display - Teilbar

2. Caméra - Camera - Kamera



D13881 12/24V
Aluminium
IP69
∠ 120°



D13617 12/24V ∠ 120°
D14124 12/24V ∠ 150°

New



D14327 12V
Motorisée + chauffante
Motorized + auto heater
Motorisierte + Heizung
IP69
∠ 120°



D14148 12/24V
IP69
∠ 150°



D13618 12/24V
IP69
∠ 120°



D13619 12/24V
IP69
∠ 120°

3. Câblage - Wiring - Verkabelung



D13620



D13621 10 m
D13622 20 m

Exemples de montage - Assembly suggestion - Montagebeispiel

D14327 + **D13622 (20 m)** + **D13887**



D13881 + **D14124** + **2 x D13621 (10 m)** + **D13501**



Plastique - Plastic housing - Kunststoffgehäuse

Ø 61 mm

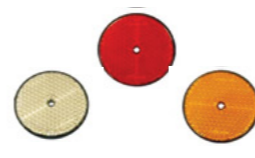

D14592
D14591
D14593

90 mm x 39 mm

70 mm



624036
624016
624026
adhésif - adhesive - Klebstreifen

Ø 85 mm

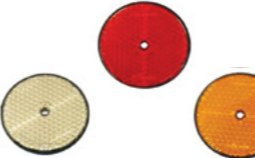

D14589
D14588
D14590

105 mm x 45 mm

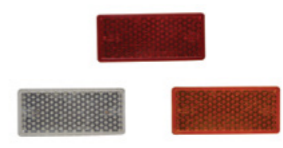

240366
240346
240356
adhésif - adhesive - Klebstreifen

57 mm x 39 mm



D14595
D14594
D14596

105 mm x 45 mm - M4

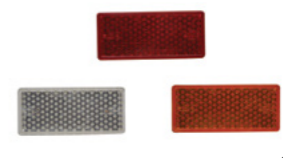

241366
241346
241356

159 mm x 159 mm x 159 mm



D14587



D14564
(56.30.000.VLG)

Affectations constructeurs
 OE applications
 Fahrzeugverwendung
 RENAULT TRUCKS p. 45
 SCANIA p. 76
 VOLVO TRUCKS p. 80

VC 70.01

E4 017016

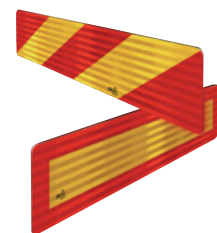

Camions / Cars et bus - Trucks / Coaches - LKW / Busse

1 x (132 x 1132)

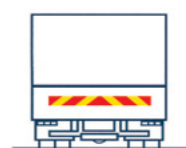

D11261 Alu 1 mm

2 x (132 x 566)



D11256 Adhésif *
D10900 Alu 1 mm
D14535 Plastique

New

4 x (132 x 283)



D11262 Alu 1 mm

* adhésif - adhesive - Selbstklebend

Remorques - Trailers - Anhänger

1 x (197 x 1132)



D11263 Alu 1 mm

2 x (197 x 566)



D11259 Adhésif *
D10901 Alu 1 mm
D14536 Plastique

New

4 x (197 x 283)



D11264 Alu 1 mm

Véhicules lents - Slow vehicles - Langsame Fahrzeuge

E R69

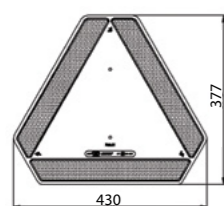

D14532



D14533



D14534



R104

E4 0001

0002

E13 0001

0002

Surface rigide - Rigid support - Auf Festaufbauten

50 m x 50 mm

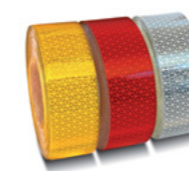

465219 ●
465229 ○
465239 ●

12,50 m x 50 mm

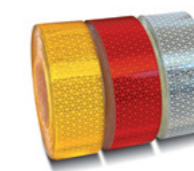

465319 ●
465329 ○
465339 ●

50 m x 50,8 mm



D12713 ●
D12715 ○
D12714 ●

Surface souple - Curtain support - Für Plane

50 m x 50 mm

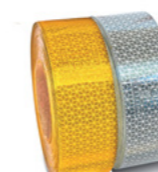

465519 ●
465529 ○

Adhésif à froid - Pressure sensitive adhesive - Kalt verklebt

50 m x 50,8 mm



D13206 ●
D13205 ○
D13207 ●

Carrés pré-espacés - segmented squares - vorgeschrittene Quadrate

Stickers citerne - Tanker stickers - Aufkleber für Tankfahrzeuge

10 m x 50 mm

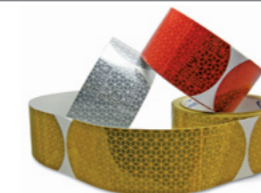

465419 ●
465429 ○
465439 ●

Découpe tous les 16 cm - Precut every 16 cm - Vorgeschritten 16 cm Schritte

2 x 9 m x 141 mm



D12020 Cl. A : 👁 ->80m

D11955 Cl. B : 👁 >500m

Classe 1 : ville et route nationale - town and trunk roads - Stadt und Landstrassen
Classe 2 : autoroutes et voies rapides - highways - Autobahnen und Schnellstrassen

2 x 45 m x 141 mm



D12021 Cl. A : 👁 ->80m

D11956 Cl. B : 👁 >500m

2 x 9 m x 141 mm



D11957 Cl. B : 👁 >500m

Véhicules pompiers - Firetruck - Feuerfahrzeuge

2 x 45 m x 141 mm



D11958 Cl. B : 👁 >500m

Véhicules pompiers - Firetruck - Feuerfahrzeuge

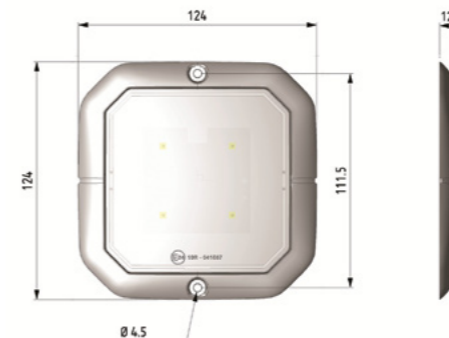

LED

⚡ 10-30V

IP69

E R10

fil nus - naked cable extremity - Kabellitze



> 4 m <
timer 5 min

500 Lumen

D14569
(22.50.LP4.VLG) 4 LEDS - PIR

Avec détecteur de mouvement et chaleur (capteur PIR) - with motion and heat detector (PIR sensor) - Mit Bewegungs- und Wärmemelder (PIR sensor)



> 4 m <
timer 5 min

500 Lumen

MASTER
D14598
(22.50.LP4.MSV) 4 LEDS - PIR

Avec détecteur de mouvement et chaleur (capteur PIR) - with motion and heat detector (PIR sensor) - Mit Bewegungs- und Wärmemelder (PIR sensor)



500 Lumen

D14567
(22.50.L04.VLG) 4 LEDS

Sans détecteur de mouvement et chaleur (capteur PIR) - without motion and heat detector (PIR sensor) - ohne Bewegungs- und Wärmemelder (PIR sensor)



750 Lumen

D14568
(22.50.L06.VLG) 6 LEDS

Sans détecteur de mouvement et chaleur (capteur PIR) - without motion and heat detector (PIR sensor) - ohne Bewegungs- und Wärmemelder (PIR sensor)

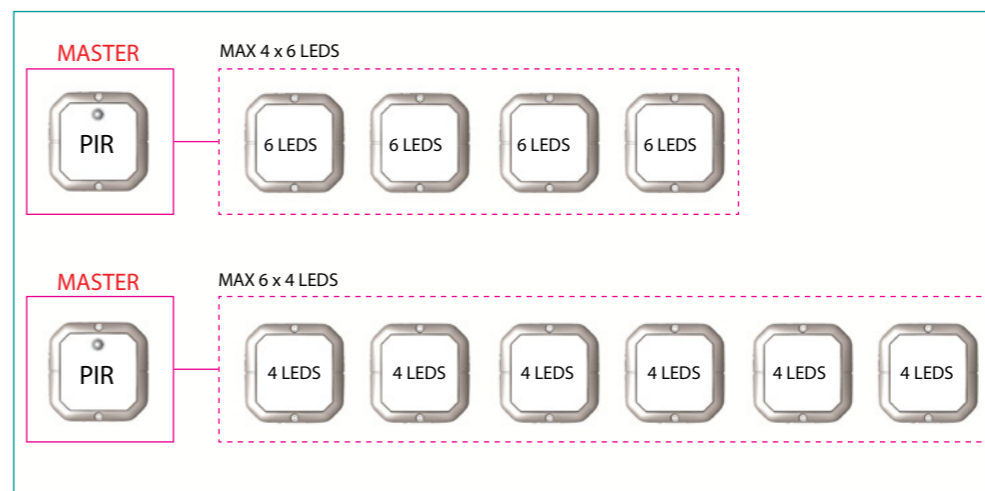

Exemple de montage Maître (PIR) + Esclaves - Assembly suggestion Master (PIR) + Slaves - Montagebeispiel Meister (PIR) + Sklave

FE02

ADR



E2 7102



Faisceau p. 270
Harness p. 270
Anschlusskabel siehe S. 270

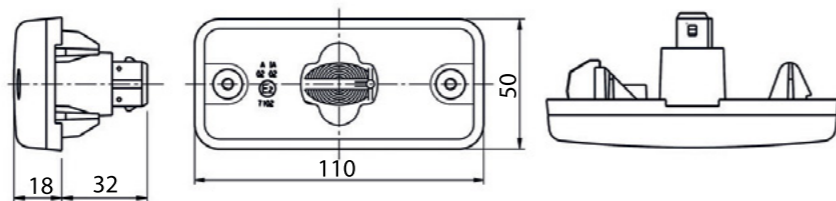

102200

W5W

clippé - clipped - clip-befestigung



001726

PL

LED

136 mm x 50 mm (entraxe 126 mm)



D14113

360 lumen
LED-12/24V

136 mm x 50 mm (entraxe 126 mm)



D14114

360 lumen
LED-12/24V

Interrupteur - Switch - Schalter



CPL



014580

Renault 5010149149
5 lampes commande warning
5 lamps, warning command
5 Glühlampen, Warnblinker

5054

New

635 mm x 282 mm x 227 mm



D14539

(50.52.925.TVC)

Avec sangle CLIP réglable - with adjustable
CLIP strap - mit verstellbaren Riemen CLIP



Max 6 kg



D14538

(50.52.925.TVC)

Avec sangle nylon - with nylon strap - mit
nylon Riemen



Max 6 kg

5051

New

786 mm x 319 mm x 229 mm



D14537

(50.51.020.VLG)

Avec sangle plastique - with plastic strap -
mit Kunststoff Riemen



Max 9 kg

SOMMAIRE DYNAMIQUE "ELECTRICITE REMORQUE"
DYNAMIC CONTENTS "ELECTRIC PRODUCTS FOR TRAILERS"
DYNAMISCHES INHALTSVERZEICHNIS "TRAILER-ELEKTRIK"

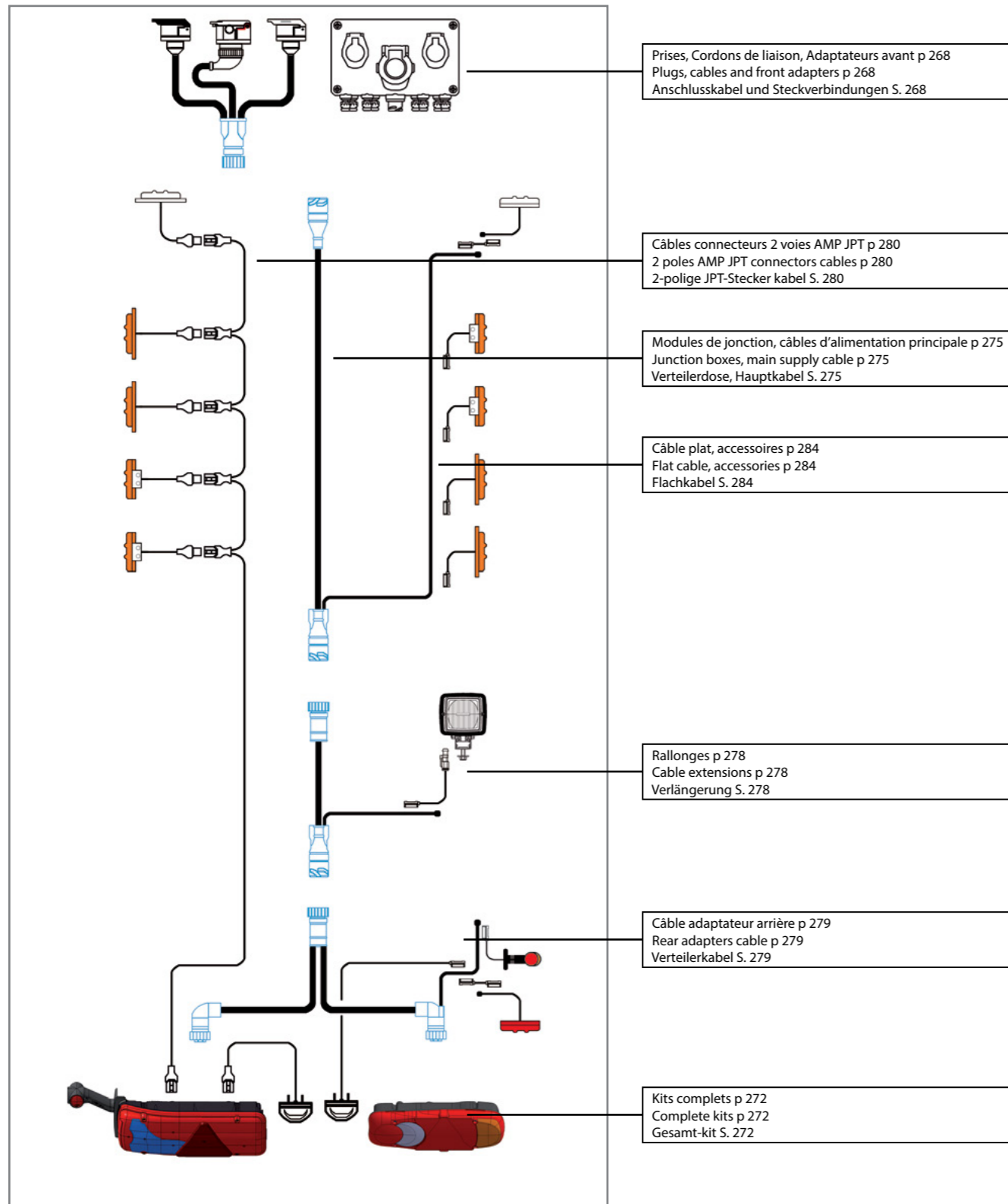

Gamme de connecteurs - Connectors range - Steckersysteme

16 voies - 16 pins - 16 Pölige

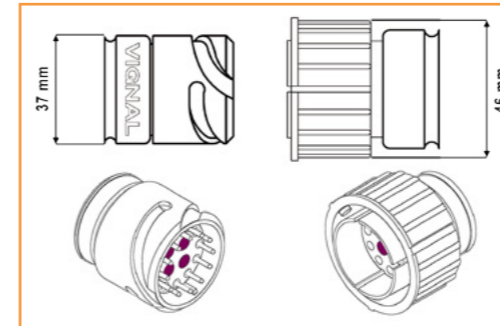

Les connecteurs 15 et 16 voies sont des connecteurs RSC qui permettent de relier les adaptateurs avant, les câbles d'alimentation principaux et les adaptateurs arrière.

The 15 and 16 pins connectors are RSC connectors which allows for the connection of front adapters, main supply cables and rear adapters.

Die 15- und 16-poligen RSC-Stecker verbinden das Hauptkabel mit dem vorderen Anschlusskabel und dem hinteren Verteilerkabel.

Comment différencier rapidement les connecteurs RSC ?
How to differentiate quickly the RSC connectors?
Wie unterscheiden sich die verschiedenen RSC-Stecker ?

Un connecteur RSC 16 voies présente 4 pins centraux alors qu'un connecteur RSC 15 voies en présente 3 (voir schéma ci-contre).

A 16 pins RSC connector has 4 central pins while a 15 pins connector has 3 (see opposite draw).

Ein 16-poliger RSC-Stecker hat 4 zentrale Kontaktpunkte, ein 15-poliger RSC-Stecker nur 3 (siehe nebenstehende Skizze).

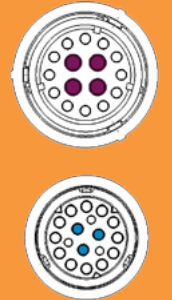

15 voies - 15 pins - 15 Pölige

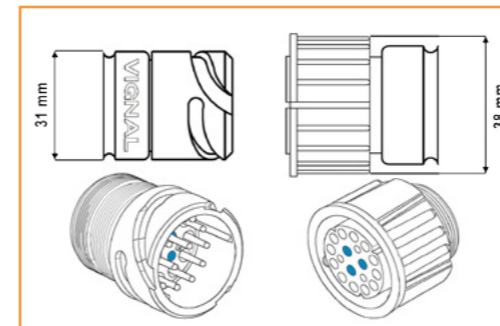

7 voies - 7 pins - 7 Pölige

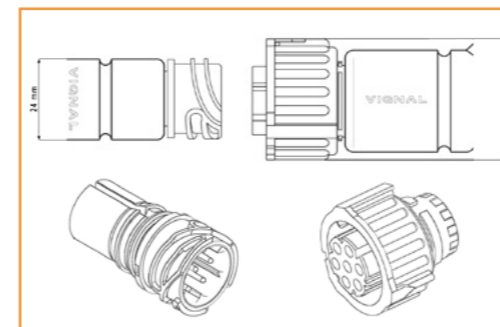

Le connecteur 7 voies permet de raccorder les feux arrière au système de câblage complet de la remorque, que ce soit un système RSC ou un système avec module de jonction.

The 7 pins connector allows for the connection of rear lamps to the complete wiring system, may it be a RSC system or a junction box system.

Über den 7-poligen Stecker werden die Heckleuchten mit den elektrischen Leitungen des Anhängers verbunden. Entweder durch das RSC System oder über eine Verteilerdose.

2 voies - 2 pins - 2 Pölige

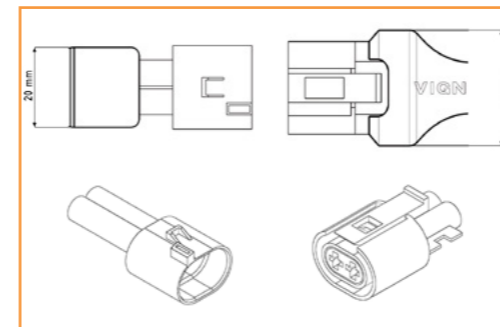

Le connecteur 2 voies position permet le raccordement de fonctions complémentaires telles que feux de position sur antenne, éclairer de plaque directement sur les feux arrière.

The 2 pins connector allows for the connection of complementary functions directly to the rear lamps such as end outline marker lamps, license plate lamps.

Über den 2-poligen Stecker werden Zusatzfunktionen wie Spurhalteleuchten oder Kennzeichenleuchten direkt an der Heckleuchte angeschlossen.

2 voies - 2 pins - 2 Pölige

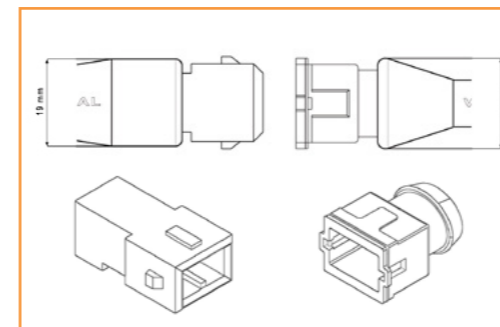

Le connecteur 2 voies JPT permet de connecter au système de câblage des feux de position avant, latéraux, arrière ainsi que des éclairers de plaque.

The JPT 2 pins connector allows for the connection to the wiring system of front, side and rear position lamps as well as license plate lamps.

Der 2-polige JPT-Stecker verbindet vordere, seitliche und hintere Positionsleuchten, sowie Kennzeichenleuchten mit dem Leitungsstrang.

7P

Métallique - Metal - Metall

24N (ISO 1185)
24S (ISO 3731)



D10873 24N

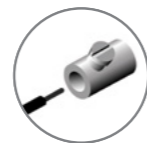

611530 24N



D10874 24S



611550 24S

Plastique - Plastic - Kunststoff



611500 24N

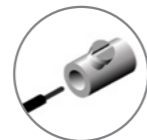

611580 24N



611510 24S



611590 24S



611520 24N



611540 24S

C7P

Métallique - Metal - Metall

New



D14313 24N
LMax 3,5 m

611140 L : 3 m, LMax 4,5 m

New



D14314 24S
LMax 3,5 m

611150 L : 3 m, LMax 4,5 m

Longueur de travail : L
Working length : L
Arbeitslänge : L

Longueur d'extension maximale : LMax
Maximum extension length : LMax
Maximale Ausziehlänge : LMax

Plastique - Plastic - Kunststoff

New



D14312 24N
LMax 3,5 m

611070 L : 3 m, LMax 4,5 m

New

D14574 L : 3 m, LMax 4,5 m

EURO6

New



D14316 24S
LMax 3,5 m

611080 L : 3 m, LMax 4,5 m

New

D14575 L : 3 m, LMax 4,5 m

EURO6

6 x 1,0 mm² + 1 x 1,5 mm²



611110 24N/24S

24N

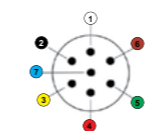

- ① - Masse
- ② - Feu de position G
- ③ - Clignotant G
- ④ - Feu Stop
- ⑤ - Clignotant D
- ⑥ - Feu de position D
- ⑦ - Commande de frein

- Common return
- L rear position lamp
- L flasher lamp
- Stop lamp
- R flasher lamp
- R rear position lamp
- Breaking control

- Masse
- Linke Schlussleuchte
- Fahrtrichtungsanzeiger links
- Bremsleuchte
- Fahrtrichtungsanzeiger rechts
- Rechte Schlussleuchte
- Steuerung Anhängerbremse

24S

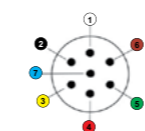

- ① - Masse
- ② - Sans affectation
- ③ - Feu de recul
- ④ - Alimentation en puissance
- ⑤ - Sans affectation
- ⑥ - Sans affectation
- ⑦ - Feu AR de brouillard

- Common return
- Without affectation
- Reverse lamp
- Power supply
- Without affectation
- Without affectation
- Fog lamp

- Masse
- Nicht belegt
- Rückfahrleuchte
- Stromversorgung (Dauerplus)
- Nicht belegt
- Nicht belegt
- Nebelschlussleuchte

15P

ISO 12098

ADR



A10060



A10061



New D14315 LMax 4,5 m

D11578 L : 3 m, LMax 4,5 m

New D14577 L : 3 m, LMax 4,5 m **EURO6**

7P-15P



611410



D13889



D11487 L : 3 m, LMax 4,5 m

New D14578 L : 3 m, LMax 4,5 m **EURO6**



A10064

PARC



611570 ABS/EBS-15P

ABS/EBS

ISO 7638-1

ADR



611560 ABS/EBS



A10062 ABS/EBS



A10065 ABS/EBS



A10066 ABS/EBS



New D14311 LMax 3,5 m

D10597 L : 3 m, LMax 4,5 m

New D14576 L : 3 m, LMax 4,5 m **EURO6**

ABS/EBS



① - Plus (+) alimentation électrovanne	Plus electrovalve	Plus Magnetventil
② - Plus (+) connexions électroniques	Plus electronics	Plus Elektronik
③ - Moins (-) connexions électroniques	Minus electronics	Minus Elektronik
④ - Moins (-) alimentation électrovanne	Minus electrovalve	Minus Magnetventil
⑤ - Connexion lampe témoin	Warning device	Warneinrichtung
⑥ - Connexion donnée CANH	CANH	Datenleitung CANH
⑦ - Connexion donnée CANL	CANL	Datenleitung CANL

15 PÔLES



① - Clignotant gauche	L flasher lamp	Fahrtrichtungsanzeiger links
② - Clignotant droit	R flasher lamp	Fahrtrichtungsanzeiger rechts
③ - Feu AR de brouillard	Fog lamp	Nebelschlussleuchte
④ - Masse	Common return	Masse
⑤ - Feu de position gauche	L rear position lamp	Linke Schlussleuchte
⑥ - Feu de position droit	R rear position lamp	Rechte Schlussleuchte
⑦ - Feu stop	Stop lamp	Bremsleuchte
⑧ - Feu de recul	Reverse lamp	Rückfahrleuchte
⑨ - Alimentation 24V	24V power supply	Stromversorgung +24V
⑩ - Capteur d'usure des freins	Worn brake indicator	Sensor für Bremsbelagverschleissanzeige
⑪ - Capteurs de pressions des freins	Brake pressure collector	Anzeige für Federspeicherbremse
⑫ - Dispositif de levage d'essieu	Adjustable suspension lift	Achsanhebung
⑬ - Masse pour contacts 14 et 15	Common return	Masse für Datenleitungen
⑭ - Bus de données	Data line	Datenleitung
⑮ - Bus de données	Data line	Datenleitung

ORIGINAL QUALITY PARTS

ORIGINAL QUALITY PARTS



Kits complets LED - LED Complete kits - LED Gesamt-kit

ADR

LED

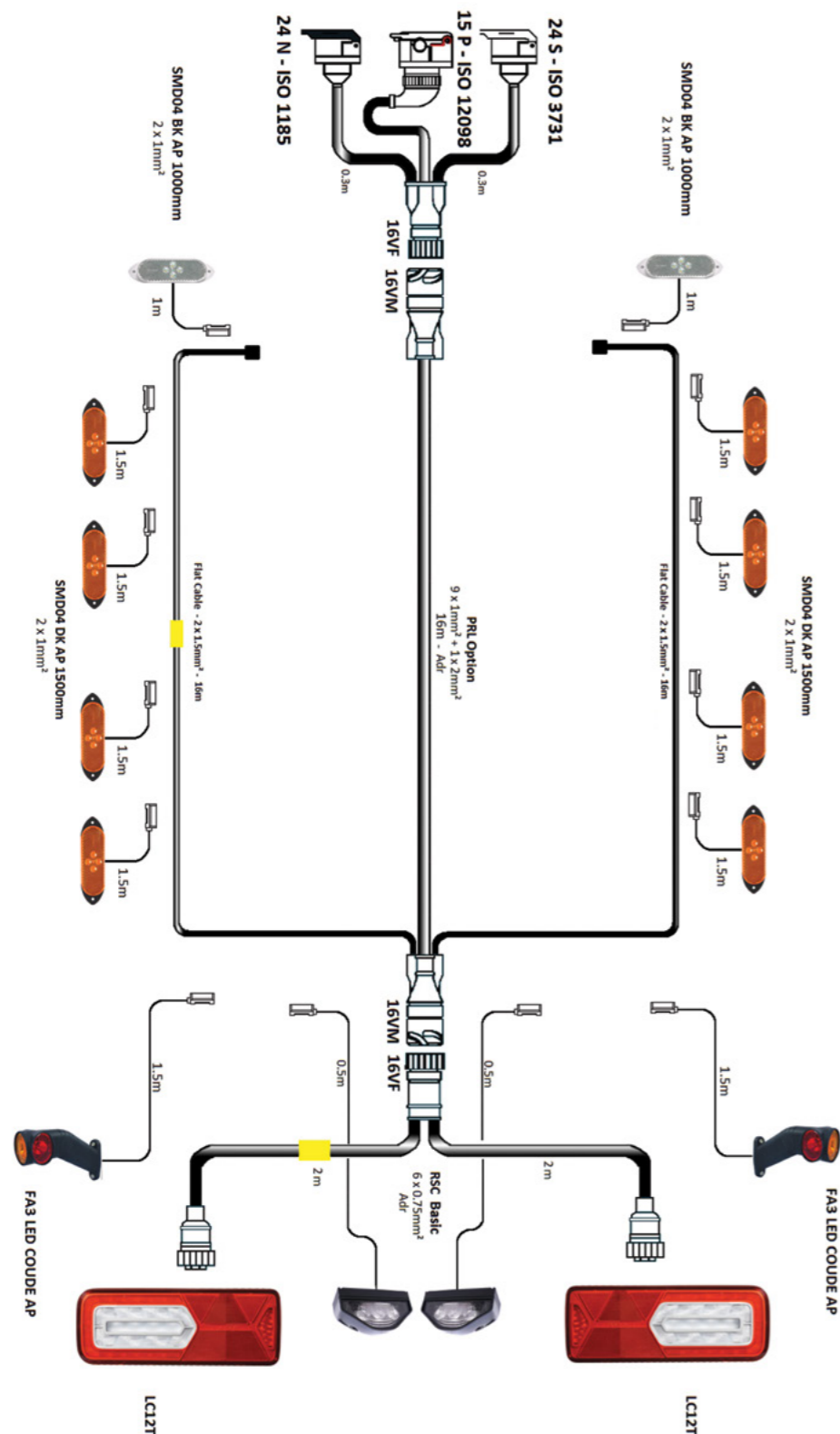

A13888

Kit complet : 2 feux arrière LC12TLED, 2 feux sur antennes DX led câbles AP 500mm, 2 Eclairseurs de plaque EPP96 LED câble ADR AP 400 mm, 8 feux de position latéraux LED SMD04 câble AP 1500 mm, 2 feux de position avant LED SMD04 câble AP 1000 mm.

Câblage système RSC de 16 m avec câbles plats latéraux de 16 m, câble adaptateur arrière de 2 m, adaptateur avant 3 prises.

Complete kit : 2 rear lamps LC12TLED, 2 LED end outline marker lamps DX click-in cable 500 mm, 2 license plate lamps EPP96 LED ADR click-in cable 400 mm, 8 LED side marker lamps SMD04 click-in cable 1500 mm, 2 LED front marker lamp SMD04 click-in cable 1000 mm.

RSC system wiring of 16 m with 16 m side flat cables, 2 m rear adapter, front adapters 3 plugs.

Komplettkit : 2 Rückleuchten LC12TLED, 2 Spurhalteleuchten DX LED mit 500mm Kabel und Click-in Anschluss, 2 LED Kennzeichenleuchten mit 400mm Kabel und Click-in Anschluss, 8 LED Seitenmarkierungsleuchten SMD04, 1500mm Kabel und Click-in Anschluss, 2 vordere LED Positionsleuchten SMD04 mit 1000mm Kabel und Click-in Anschluss.

16m RSC Hauptkabel und 2 seitliche 16m lange Flachbandkabel, hinteres 2m langes Verteilerkabel, vorderes Anschlusskabel mit 3 Steckdosen.

ADR

Kits complets - Complete kits - Gesamt-kit

ADR

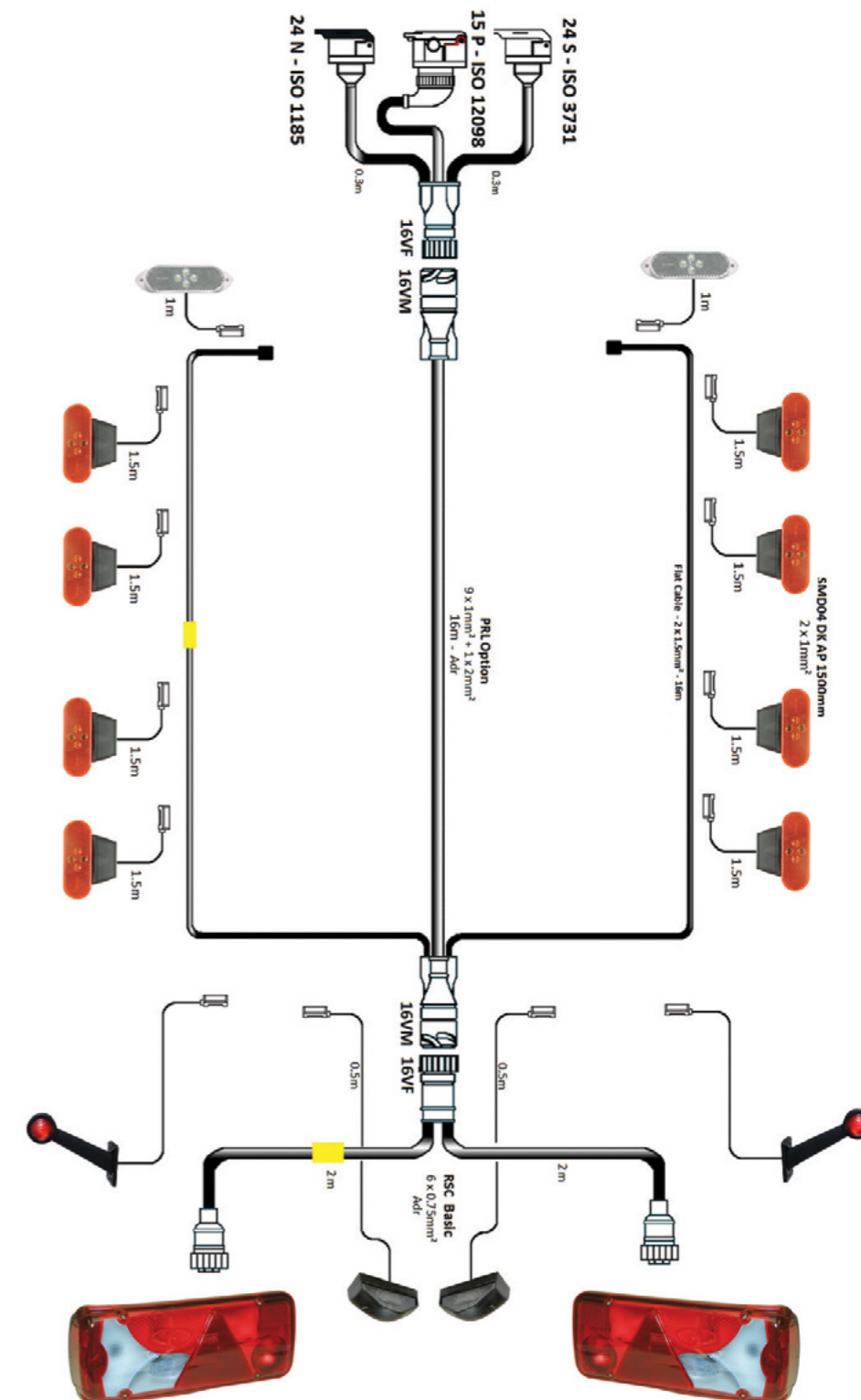

A11212

Kit complet : 2 feux arrière LC8T, 2 feux sur antennes DX câbles AP 600mm, 2 Eclairseurs de plaque EPP96 câble ADR AP 410 mm, 8 feux de position latéraux LED SMD04 bride coudée câble AP 1500 mm, 2 feux de position avant LED SMD04 câble AP 1000 mm.

Câblage système RSC de 16 m avec câbles plats latéraux de 16 m, câble adaptateur arrière de 2 m, adaptateur avant 3 prises

Complete kit : 2 rear lamps LC8T, 2 end outline marker lamps DX click-in cable 600 mm, 2 license plate lamps EPP96 ADR click-in cable 410 mm, 8 LED side marker lamps SMD04 90° bracket click-in cable 1500 mm, 2 LED front marker lamp SMD04 click-in cable 1000 mm.

RSC system wiring of 16 m with 16 m side flat cables, 2 m rear adapter, front adapters 3 plugs

Komplettkit : 2 Rückleuchten LC8T, 2 Spurhalteleuchten DX mit 600mm Kabel und Click-in Anschluss, 2 Kennzeichenleuchten mit 410mm Kabel und Click-in Anschluss, 8 LED Seitenmarkierungsleuchten SMD04 mit 90° Montagewinkel, 1500mm Kabel und Click-in Anschluss, 2 vordere LED Positionsleuchten SMD04 mit 1000mm Kabel und Click-in Anschluss.

16m RSC Hauptkabel und 2 seitliche 16m lange Flachbandkabel, hinteres 2m langes Verteilerkabel, vorderes Anschlusskabel mit 3 Steckdosen.

Système MDJ - Box system - Verteilerdose

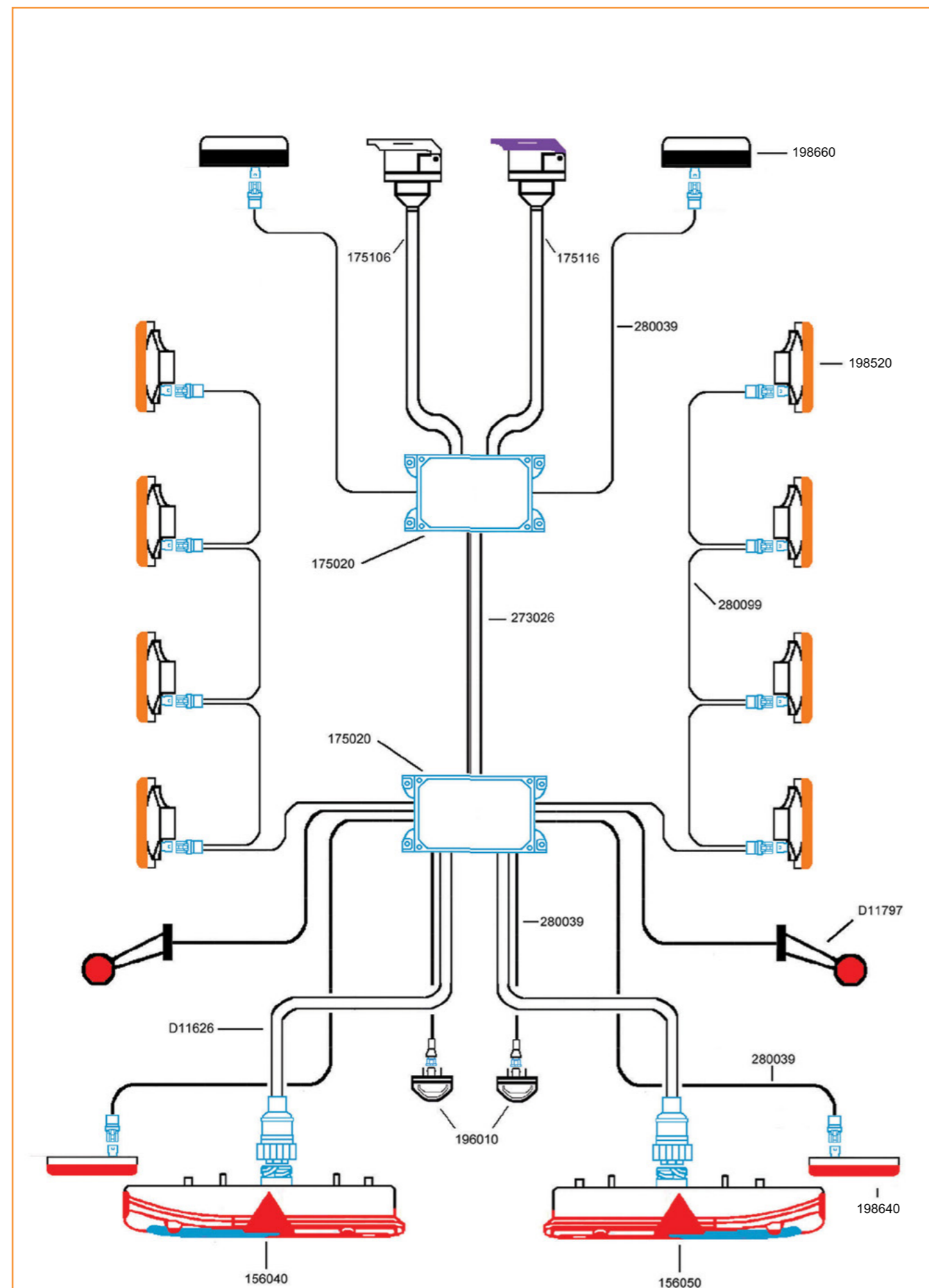

Exemple de montage - Assembly suggestion - Montagebeispiel

MDJ



Système MDJ - Box system - Verteilerdose

175020

D11889

175086 cable Ø 5,9-6,9

177136 cable Ø 8,3-10

175096 cable Ø 11-12

175076

177226 Pour gaine annelée
For conduit
Für GGVS Wellrohr

D13248

BX 3540

611090
8 voies - 8 ways - 8 Verbindungen

LED

Boitier de compatibilité universel LED
Universal LED Compatibility gear
Universal-LED-Vorschaltgerät

D13237 fils nus - naked cable extremity - kabellitze

D13502 pour module de jonction - for junction box - für Verteilerbox

D13234 RSC Vignal 16 voies - poles - pölige stecker

D13235 RSC Vignal 15 voies - poles - pölige stecker

AMP 1.5



D11868 7V

Connecteur AMP 1.5 simple
Single AMP 1.5 connector
Anschlussstecker AMP 1.5

Pour / For / Für
LC5, LC7, LC8, LC9, LC12, LC11, LC10



HDSCS

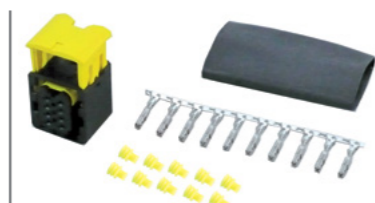

D13878 8V

Connecteur HDSCS simple
Single HDSCS connector
Anschlussstecker HDSCS

Pour / For / Für
LC8



JPT



D13876 2V

Connecteur JPT 2 voies
2 poles JPT connector
Anschlussstecker 2 polig JPT

Pour / For / Für
EPP98, SMD98,
FPL93, FE98



D13877 3V

Connecteur JPT 3 voies
3 poles JPT connector
Anschlussstecker 3 polig JPT

Pour / For / Für
ICDL94



2V POS



D13879 2V

Connecteur 2 voies position femelle
2 pin female connector
Weiblich Anschlussstecker 2 polig

Pour / For / Für
LC8T, DX



D14214 2V

Connecteur 2 voies position mâle
2 poles male connector
Männlich Anschlussstecker 2 polig

DT



D14170 2V

connecteur 2 voies DT
2 poles DT connector
Anschlussstecker 3 polig DT

Pour / For / Für
feux de travail, work lights,
Arbeitsscheinwerfer

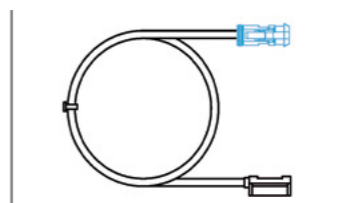

R12486 1500 mm

câble adaptateur DT 2V-CLICK-IN
adapter cable DT 2V-CLICK-IN
Adapterkabel DT 2V-CLICK-IN

New



D14436 4V

connecteur 4 voies DT06-4S femelle
4 poles DT06-4S femaleconnector
Weiblich Anschlussstecker 4 polig DT06-4S

Pour / For / Für
CTL15, BL15



New



D14434 4V

connecteur 4 voies DT04-4P mâle
4 poles DT04-4P male connector
Männlich Anschlussstecker 4 polig DT04-4P

New



D14437 4V mini

connecteur 4 voies DTM06-4S femelle
4 poles DTM06-4S femaleconnector
Weiblich Anschlussstecker 4 polig DTM06-4S

Pour / For / Für
CTL15, BL15



New



D14435 4V mini

connecteur 4 voies DTM04-4P mâle
4 poles DTM04-4P male connector
Männlich Anschlussstecker 4 polig DTM04-4P

New



D14352 6V

connecteur 6 voies DT
6 poles DT connector
Anschlussstecker 6 polig DT

Pour / For / Für
3800



SUPERSEAL



D13880 SUPERSEAL 2V

Connecteur SUPERSEAL 2 voies femelle
2 poles female SUPERSEAL connector
Weiblich Anschlussstecker 2 polig

Pour / For / Für
SMD98, FPL93, LC12, ICDL10



D14208 SUPERSEAL 2V

Connecteur SUPERSEAL 2 voies mâle
2 poles male SUPERSEAL connector
Männlich Anschlussstecker 2 polig

FCA

ADR

Pour feux arrière type LC5, LC6, LC7, LC8, LC9 p.151

For rear lamps LC5, LC6, LC7, LC8, LC9 p.151

Für Heckleuchten vom Typ LC5, LC6, LC7, LC8, LC9 p.151

Exemple de montage p. 274
Assembly suggestion p. 274
Montagebeispiel siehe S. 274



Câbles feux arrière - Rear lamp cables
Anschlusskabel Heckleuchten

AMP 1.5

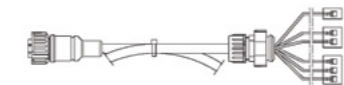

D11626 2500 mm

R13195* 2500 mm

D11627 4300 mm

Pour module de jonction 175020
For junction box 175020
Für Verteilerdose 175020
* Connecteur coudé à 90°, 90° connector, 90° gewinkelter Stecker



AMP 1.5

AMP 1.5



D11628 2500 mm

280049* 4000 mm

* Connecteur coudé à 90°, 90° connector, 90° gewinkelter Stecker

Rallonges - Extension leads - Verlängerungsschnur

AMP 1.5

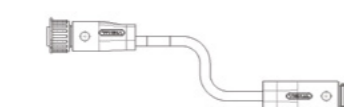

D12449 1000 mm

D12450 2000 mm

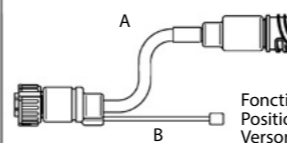

R12575 A: 3 m / B: 3 m

R12576* A: 0,5 m / B: 3 m

* Pour / For / Für LC9 p. 167

Doubleur de feux - Double rear lamp cable -
Kabel für zwei Rückleuchten

AMP 1.5
Mâle - Male - Männlich

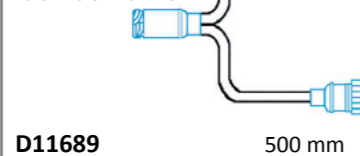

D11689 500 mm

AMP 1.5
Femelle - Female - Weiblich

AMP 1.5
Femelle - Female - Weiblich

Capot de protection - Protective cover - Schutzkappe



D13726

Capot de protection pour connectique coudée feu arrière
Protective cover for rear lamp 90° connector
Schutzkappe für Heckleuchte mit gewinkelttem Stecker



D13725

Capot de protection pour connectique droite feu arrière
Protective cover for rear lamp straight connector
Schutzkappe für Heckleuchte mit geradem Stecker

FCA

ADR

Exemple de montage p. 272
Assembly suggestion p. 272
Montagebeispiel siehe S. 272

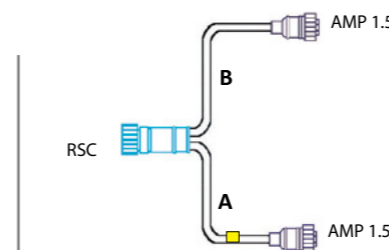

D10513 A: 3,5 m / B: 3,5 m 16V

Faisceau pour feux arrière avec surmoulages droits
Rear lamp cable with straight overmoulding
Leitungssatz für Heckleuchten mit geradem Anschlussstecker
■ = gauche - left - links

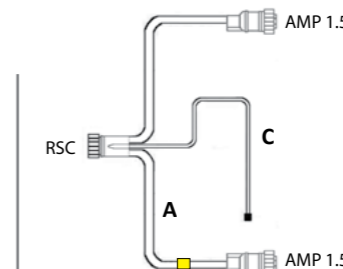

D13262 A: 1,5 m / B: 2,5 m / C: 1,2 m 15V

Faisceau pour feux arrière avec câbles plats et surmoulages droits
Rear lamp cable with flat cables and straight overmoulding
Leitungssatz für Heckleuchten mit geradem Anschlussstecker und Flachkabel für
■ = gauche - left - links

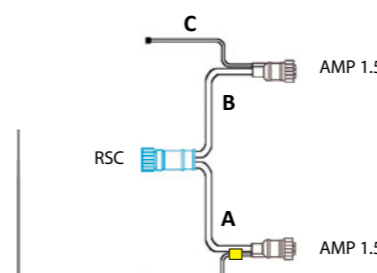

D10514 A/B: 2 m / C: 0,5 m 16V

D10515 A/B: 2 m / C: 16 m 16V

R12499 A: 2,5 m / B: 1,5 m / C: 0,5 m 15V

Faisceau pour feux arrière avec câbles plats et surmoulages droits
Rear lamp cable with flat cables and straight overmoulding
Leitungssatz für Heckleuchten mit Flachkabel und geradem Anschlussstecker
■ = gauche - left - links

New

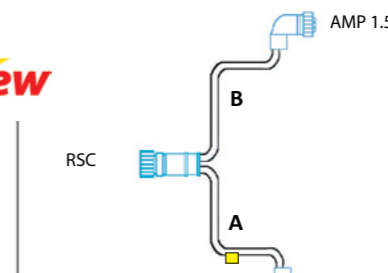

R14407 A: 2 m / B: 2 m 16V

Faisceau pour feux arrière LC12T avec surmoulages coudés
LC12T Rear lamp cable with 90° overmoulding
Leitungssatz für LC12T Heckleuchten mit 90° gewinkelter Stecker
■ = gauche - left - links

Pour / For / Für LC12



Kits de réparation pour feux arrière - Rear lamps repair kits -
Reparaturatz für Heckleuchten



D11868 7V

Connecteur AMP 1.5 simple
Single AMP 1.5 connector
Anschlussstecker AMP 1.5



D11865 500 mm

Connecteur AMP 1.5 avec câble plat
AMP 1.5 connector with flat cable
Anschlussstecker AMP 1.5 mit Flachkabel



KIT

FCA

ADR

**Câbles feux latéraux - Side marker lamp cables
Kabel für Positionsleuchten**

Pour éclairage de plaque EPP98 p.193 et feux de position SMD98, FE98 et FPL93 p.203

For number plate lamp EPP98 p.193 and position lamp SMD98, FE98 and FPL93 p.203

Für Kennzeichenleuchte EPP98 S.193 und Markierungsleuchten SMD98, FE98 und FPL93 S.203

Exemple de montage p. 274
Assembly suggestion p. 274
Montagebeispiel siehe S. 274



Femelle
Female
Weiblich

AMP JPT

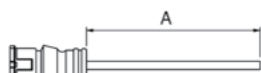

AMP JPT

Fils nus
Naked cable extremity
Kabellitze

280009	A : 2 m
280019	A : 4 m
280029	A : 6 m

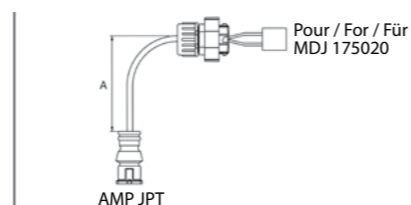

280039 A : 4 m

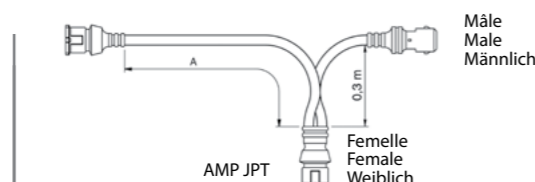

280059 A : 3,5 m

280069 A : 5,5 m

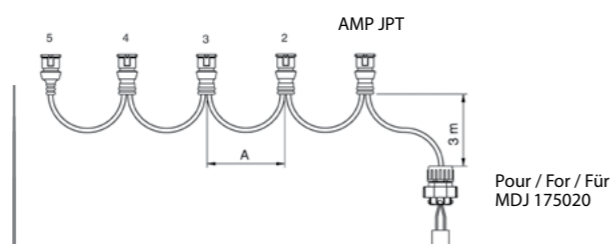

3 x JPT	280089	A : 3,5 m	280129	A : 5,5 m
4 x JPT	280099	A : 3,5 m	280139	A : 5,5 m
5 x JPT	280109	A : 3,5 m	280149	A : 5,5 m

KIT

**Kits de réparation pour feux latéraux - Side marker lamps repair kits
Reparaturatz für Positionsleuchten**

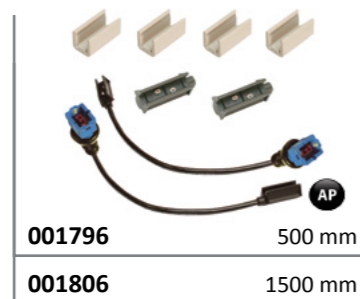

001796 500 mm
001806 1500 mm



001786 500 mm

FCA

ADR



2V POS

Pour éclairage de plaque EPP96 p.193 et feux de position SMD98, DX p.211

For number plate lamp EPP96 p.193 and position lamp SMD98, DX p.211

Für Kennzeichenleuchte EPP96 S.193 und Markierungsleuchten SMD98, DX S.211

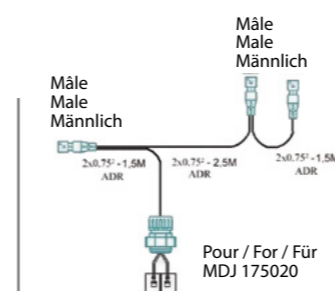

R14172 5,5 m

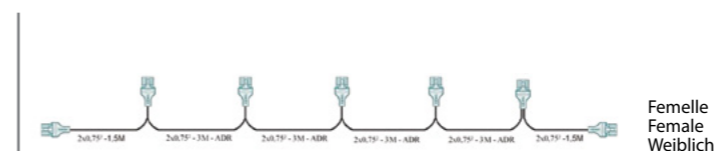

R14171 19 m

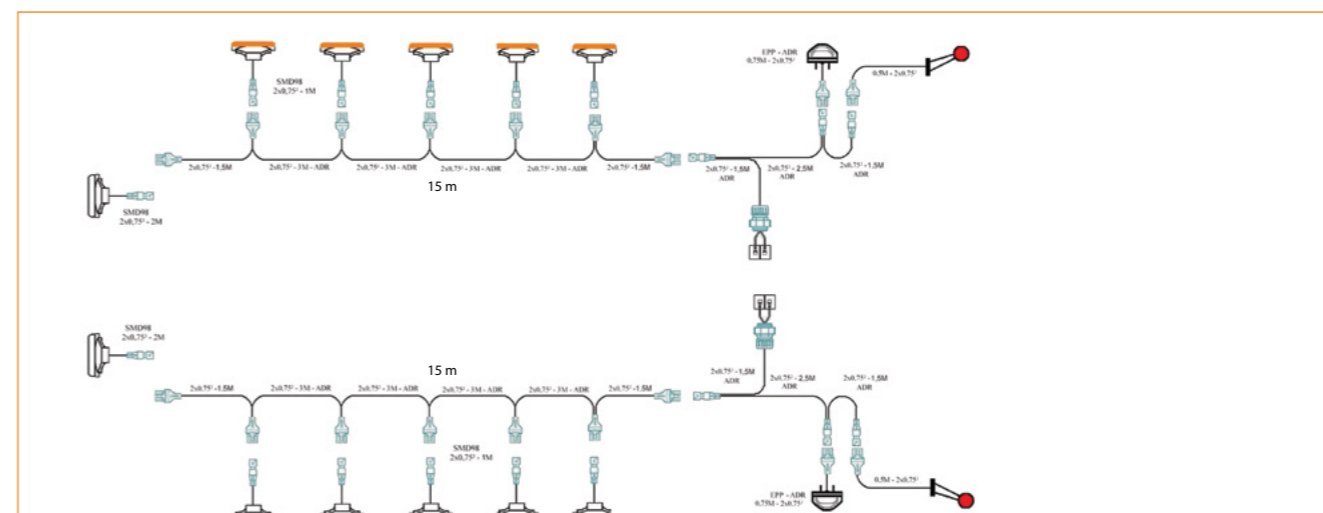

D13295
Kit : 2 feux sur antennes DX câbles 2V 500mm, 2 Eclairage de plaque EPP96 câble 2V 750 mm, 8 feux de position latéraux LED SMD98 bride coudée câble 2V 1000 mm, 2 feux de position avant LED SMD98 bride coudée câble 2V 1000 mm.
Kit : 2 end outline marker lamps DX 2V cable 500 mm, 2 license plate lamps EPP96 2V cable 750 mm, 8 LED side marker lamps SMD98 90° bracket 2V cable 1000 mm, 2 LED front marker lamp SMD98 90° bracket 2V cable 1000 mm.
Kit : 2 Spurhalteleuchten DX mit 500mm Kabel und 2V Anschluss, 2 Kennzeichenleuchten mit 750mm Kabel und 2V Anschluss, 8 LED Seitenmarkierungsleuchten SMD98 mit 90° Montagewinkel, 1000mm Kabel und 2V Anschluss, 2 vordere LED Positionsleuchten SMD98 mit 90° Montagewinkel, 1000mm Kabel und 2V Anschluss

New



SUPERSEAL

Pour éclairage de plaque EP-P96LED p.193 et feux de position SMD98, DX p.211

For number plate lamp EPP96LED p.193 and position lamp SMD98, DX p.211

Für Kennzeichenleuchte EPP96LED S.193 und Markierungsleuchten SMD98, DX S.211

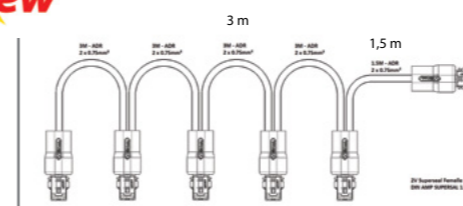

R14173 17,5 m

Autoperforant pour câble plat
Click-in for flat cable
Click-in Anschluss für Flachkabel

PRL

ADP

Câble d'alimentation principale - Main supply cable - Hauptkabel

Exemple de montage p. 274
Assembly suggestion p. 274
Montagebeispiel siehe S. 274

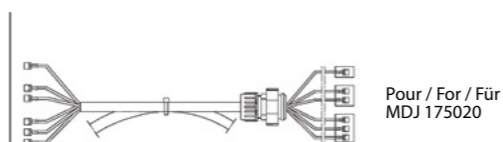

273026 15 m

Prolongateur pour MDJ 175020 p. 269
Main supply cable for 175020 p. 269
Haupt-Verlängerungskabel für 175020 p. 269



D10505 16 m **16V**

D13263 15 m **15V**

Prolongateur RSC simple
Single RSC Main supply cable
Haupt-Verlängerungskabel für RSC

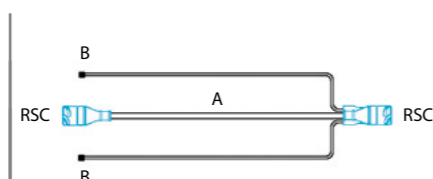

D10510 A: 10 m / B: 10 m **16V**

D10508 A: 16 m / B: 16 m **16V**

D13260 A: 15 m / B: 0,27 m* **15V**

Prolongateur avec câbles plats
Main supply cable with flat cables
Haupt-Verlängerungskabel mit eingegossenem Flachkabel
* avec autoperforants / with click-in / mit click-in



D13249 **16V**

Connecteur RSC femelle presse étoupe + contacts
Female RSC connector with o'ring + contacts
Weiblicher RSC Stecker mit Kabelverschraubung + Kontakt



D13250 **16V**

Connecteur RSC mâle presse étoupe + contacts
Male RSC connector with o'ring + contacts
Männlicher RSC Stecker mit Kabelverschraubung + Kontakt

Adaptateurs avant - Front adapters - Anschlusskabel



24N 24S / 15P

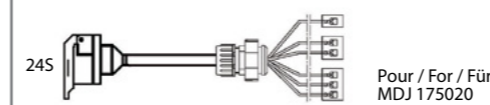

175106 700 mm

Faisceau prises 24S
Cable with plugs 24S
Anschlusskabel mit Steckdosen 24S

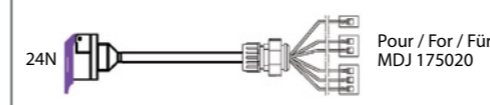

175116 700 mm

Faisceau prises 24N
Cable with plugs 24N
Anschlusskabel mit Steckdosen 24N

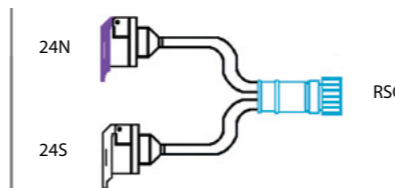

D10504 1000 mm **16V**

D13257 1500 mm **15V**

Faisceau prises 24N / 24S
Cable with plugs 24N / 24S
Anschlusskabel mit Steckdosen 24N / 24S

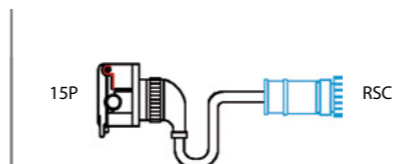

D13254 1000 mm **16V**

D13255 600 mm **15V**

Faisceau prises 15P
Cable with plugs 15P
Anschlusskabel mit Steckdosen 15P

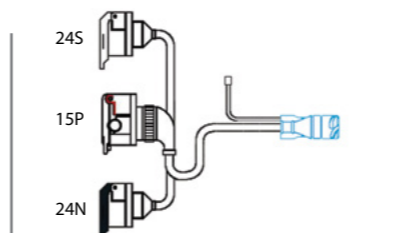

D13256 300 mm **15V**

Faisceau prises 15P / 24N / 24S
Cable with plugs 15P / 24N / 24S
Anschlusskabel mit Steckdosen 15P / 24N / 24S

Prises et cordons de liaison p.268
Cable and plugs p.268
Anschlusskabel und Steckverbindungen S.268

Exemple de montage p. 274
Assembly suggestion p. 274
Montagebeispiel siehe S. 274

Exemple de montage p. 272
Assembly suggestion p. 272
Montagebeispiel siehe S. 272

ORIGINAL QUALITY PARTS

ORIGINAL QUALITY PARTS

CP

ADR

Câble plat
Flat cable
Flachkabel

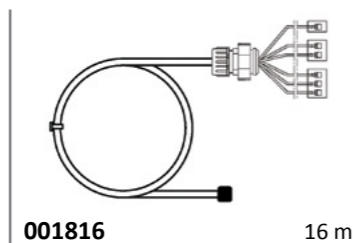

001816 16 m

Pour / For / Für
MDJ 175020

Câble plat pour module de jonction 175020 p. 274
Flat cable for junction box 175020 p. 274
Flachkabel für Verteilerdose 175020 p. 274

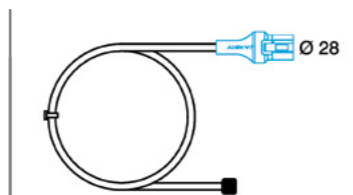

D11147 500 mm

D10520 16 m

Pour / For / Für
LC8T

Câble plat optionnel avec connecteur 2 voies
pour repiquage sur feu arrière LC8

Optional flat cable with 2- pin connector to
plug-in LC8 rear lamp

Flachkabel mit 2-polig Anschlussstecker zum
direkten Anschluss an die Heckleuchte LC8

New

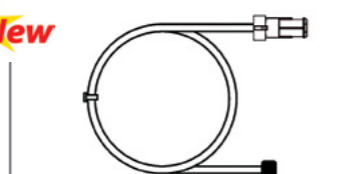

R14412 16 m

Pour / For / Für
LC12T

Câble plat optionnel avec connecteur 2 voies
SUPERSEAL pour repiquage sur feu arrière LC12T

Optional flat cable with SUPERSEAL 2- pin
connector to plug-in LC12T rear lamp

Flachkabel mit SUPERSEAL 2-polig Anschluss-
stecker zum direkten Anschluss an die
Heckleuchte LC12T

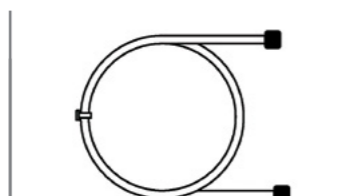

D11268 16 m

A10779 100 m

Câble plat - Flat cable - Flachkabel



4330012

Bouchon pour câble plat
Cap for flat cable
Abschlussstopfen für Flachkabel

ACC



151236

Verrou pour click-in à usage unique
Clamp for click-in, single use
Einmal click-in Riegel



001826

Obturateur seal-in
Seal-in obturator
Verschlusshülse seal-in



9115118

Pince pour click-in
Pliers for click-in
Montagezange für click-in Befestigung



D13251

1 Kg

Graisse anti-corrosion
Anti-corrosion grease
Korrosionsschutzfett

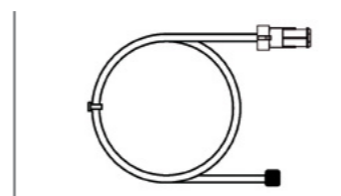

R14339 7,5 m

4V DT

Pour / For / Für
CTL15

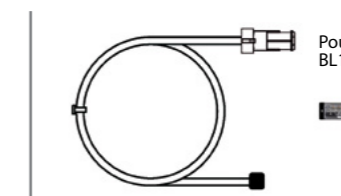

R14338 7,5 m

4V DT

Pour / For / Für
BL15

ACC



D10517 500 mm

D10518 1500 mm

D10519 3500 mm



D10132 200 mm

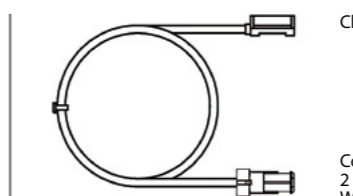

R14416 1500 mm

Click-in

Connecteur SUPERSEAL 2 voies femelle
2 poles female SUPERSEAL connector
Weiblich Anschlussstecker 2 polig

	OES	VIGNAL	OES	VIGNAL
BOBCAT	728786	R12931	5001020317	119400
	7027476	052500	5001020318	119410
	7028787	R12934	5001834505	195030
	7164110	152150	5001834564	001606
	7164111	152150	5001834568	001616
	7175124	196010	5001834576	195060
			5001837993	001626
DAF	0698603	040500	5001847589	001726
	0867930	196010	5010086923	185010
	1272653	067500	5010086924	185030
	1284211	167640	5010104837	185050
	1284212	167630	5010177690	191100
	1304788	168010	5010179915	167150
	1304789	168020	5010197259	191170
	1329718	193020	5010197260	191110
	1401713	152170	5010197261	191140
	1401731	152180	5010197262	191120
	1403887	195010	5010217022	185020
	1451482	052500	5010286898	195000
	1519358	D12953	5010286903	119500
	1608352	001726	5010286904	119510
	1625985	169160	5010306792	193020
	1625986	169170	5010403075	197080
	1626101	119550	5010403076	197070
	1626102	001616	50101972564	191150
	1653605	193200		
	1660967	168890	IVECO	791123
	1660968	169380		152180
	1846491	117000		1608352
	1846492	117010		41200664
	1875576	155110		41221040
	1875577	155100		41221041
	1875578	155120		42535711
	1875579	155140		42555041
	1875580	155130		42555042
	1875581	155150		42555131
	1914690	055020		42555132
	1914691	055030		42555132
	1973239	001830		42566495
	2922224	141640		42566495
	1626319/1284213	168100		69500026
	1626320/1284214	168390		69500026
	1814096/1815754	109010		69500032
				69500032
FIAT	1305797	193170		69500044
	1372698080	153280		69500044
	1372699080	153270		69500047
	1356794080 / 71749250	193280		69500047
				69500590
				69500591
				93161844
HEULIEZ	3156201	067000		97163920
	0190408700	181000		97163920
	0190439000	179240		99463242
	0190552400	181050		99463242
	190825600	193020		99463243
	5010104837	185050		99463244
	5010217022	185020		500308514
	5010271501	195030		500341613
	5010312524	195060		500356782
HEULIEZ	2773801/2870801	167150		500356783
				504097923
IRISBUS	504217797	198650		5001834568
	5000461058	181000		5001834568
	5000461059	181050		5801363428
	5000786265	179210		5801363430
	5000804703	079010		5801363431
	5001020257	119550		5801363432
				5801426889
				5801426894
				5801426912
				5801426917
				5801426975
				5801426977
				5801426979
				5801572018

	OES	VIGNAL	OES	VIGNAL
	5801572024	110550		
	5801631615	198760		
	5801637182	155480		
	5801637199	155450		
	5801637201	155460		
	5801637202	155470		
	5801757326	155500		
	5801757328	155490		
	5802055272	155540		
	5802055273	160140		
	5802062689	160150		
	58012000568	160080		
	58012000570	160110		
	58012000573	160100		
	58012000767	160090		
	58012000770	160130		
	58012000772	160120		
	A610067-002	052500		
	R504083205	168480		
MAN	7CE945095	155550		
	7CE945096	155560		
	8125225-6033/6464	168090		
	8125225-6034	168100		
	8125225-6469/6470	166700		
	8125225-6523	169170		
	8125225-6524	169160		
	8125225-6526	169180		
	8125225-6528	168490		
	8125225-6530	169190		
	8125225-6544	156200		
	8125225-6545	156210		
	8125225-6547	156220		
	8125229-6051	067500		
	8125229-6059	056500		
	8125229-6060	056510		
MANITOU	163782	500930		
	163783	500940		
	223766	152180		
	223767	152180		
	227330	610091		
	959694	D14380		
	959695	D14381		
MANITOWOC	03137250	156860		
	03137251	156870		
	03138527	198660		
	03320937	198520		
	03320938	152180		
	03320939	152170		
	03329492	198640		
	03329572	D10493		
MERCEDES	A9068200464	156340		
	A9068201764	156350		
	A9068262056	056540		
	A9068262156	056550		
	A9495400104	196170		
NISSAN	26164-9X402	119550		
	26244-9X400	001616		
	26554-9X126	052500		
	26555-9X125	152180		
	26555-9X126	152170		
	26555-9X128	153120		
OPEL	4421269	196010		
	4421265/6	152180		
PSA	63501FS / 9815126980	153280		
	6350FS / 9815127080	153270		
RENAULT AGRI	7700027564	196020		
	7700694211	125200		
	7700694212	125100		
RENAULT TRUCKS	003603705	016600		
	0027567009	116600		
	5000296591	166100		
	5000296591	166000		
	5000296592	167100		
	5000296592	167000		
	5000296593	066000		
	5000296594	067000		
	5000296718	088010		
	5000459966	117920		
	5000459967	117910		
	5000461058	181000		
	5000461059	181050		
	5000462758	10850603		
	5000463046	186030		
	5000463047	186040		
	5000589493	135200		
	5000623050	188310		
	5000623398	125430		
	5000789306	182020		
	5000803784	035000		
	5000807304	040000		
	5000808095	087040		
	5000808166	040500		
	5000808171	141000		
	5000808172	141500		
	5000810542	025210		
	5001825075	025200		
	5001831194	168220		
	5001832999	168260		
	5001834559	119410		
	5001834560	119400		
	5001834561	195010		
	5001834565	119450		
	5001834568	001616		
	5001835853	168140		
	5001846843	152000		
	5001846844	152010		
	5001846845	152040		
	5001846846	152050		
	5001846847	152020		
	5001846848	152030		
	5001846849	152060		
	5001846850	152070		
	5001847153	052500		
	5001847582	169060		
	5001847583	169070		
	5001847584	169000		
	5001847585	169010		
	5001847586	169020		
	5001847587	169030		
	5001847588	067500		
	5001847589	001726		
	5001847597	119470		
	5001857964	152510		

	OES	VIGNAL		OES	VIGNAL
	5001857965	152520		1365966	168380
	5001857966	152610		2020496	D10596
RENAULT TRUCKS	5001857967	152620		2160127	155090
	5001858092	152500		2160128	155080
	5001858093	152600		2340796	155520
	5001862030	102200		1756751	156780
	5001862030	193200		2021575	156780
	5001864535	169310		2129987	156780
	5001864536	169320		1756754	156770
	5001864537	169330		2021579	156770
	5001870556	152180		2129985	156770
	5010040505	178340		1784669/ 2129992	056540
	5010217022	185020		1784670/ 2129991	056550
	5010217023	185040		1791369	156790
	5010231061	117700		2021576	156790
	5010231161	125200		2129988	156790
	5010271775	10850605		2021578/ 2129986	155020
	5010271807	185160			
	5010293829	169010	UD TRUCKS	84655961	120000
	5010306711	118440		261319Z01B	153860
	5010306792	193020		261319Z01C	153870
	5010392231	052000		261319Z01D	153880
	7420802348	159010		261319Z01E	153890
	7420802350	159020		265109Z00A	196010
	7420802353	159030		265509Z00A	052500
	7420802418	059000			
	7420856783	D14564	VOLKSWAGEN	7CA945095	155570
	7420862038	152190		7CA945096	155580
	7420862041	152200		2E0945095A	156340
	7421106206	198650		2E0945096A	156350
	7421137718	104450		2E0945111A	056540
	7421268609	191170		2E0945112A	056550
	7421396991	D13019			
	7421396993	D13020	VOLVO	11170068	198520
	7422800391	058000		20480486	198650
	7425982261	158030		20537280	052000
	7425982262	158040		20717520	102200
	7482252291	115040		20721495	196010
	7482252506	115000		20745060	052500
	7482255014	115030		20745066	001726
	7482266219	113020		20745225	195010
	7482285707	113030		20745227	001616
	7482346591	115020		20769775	159010
	7482367030	115010		20769776	159020
	7482392733	198620		20769777	159030
	7482586940	198740		20769783	152190
	7484185589	D14161		20769784	152200
	7485118470	152170		20789440	198620
	7700353021	196020		20802418	059000
	7700377094	197040		20872890	D12111
	7700377095	197050		20882716	D12112
	7700377130	620236		21087346	207010
	7700377208	198510		21087347	207020
	8200602314	620056		21214524	114020
	265100848R	196010		21214534	114000
	265500292R	152180		21319995	112030
	5010306792	193020		21319996	112020
	7484538758	193020		21341202	119550
	7420862032/2035	152880		21346521	111020
	7421430181	104570		21346522	111030
	7482522006	104570		21368779	116050
				21368781	116060
				21368782	116030
				21368783	116020
SCANIA	1350343	067500		21396991	D13019
	1365963	168350		70364301	198640
	1365964	168360			
	1365965	168370			

	OES	VIGNAL
	82116545	207000
	82150539	114010
	82151157	111000
	82151205	111010
VOLVO	82202076	113000
	82278930	112010
	82278938	112000
	82348508	116040
	82349220	116010
	82349221	116000
	82466757	D10596
	82467736	107500
	82467737	107510
	82849905	058000
	84044658	198740
	84122332	059500
	84185589	D14161
	85105029	001766
	20734485 / 84538758	193020
	20769781/82	152880
	21735299 / 84441937	159530
	21735301 / 84441936	159520
	82114500 / 82355684	107010
	82114502 / 21478751	107050
	82114504 / 21448885	107040
	82114506 / 82355678	107000
	82483073 / 84441760	159510
	82483074 / 84441759	159500
	82849894	158030
	84195505	158030
	84441766	158030
	82849923	158040
	84195521	158040
	84441768	158040
	82849925	158050
	84195519	158050
	84441767	158050

Par référence - By part number - nach Artikelnummer

000046	178, 186	060010	154	111030	197	152070	58
000086	200, 216	066000	177	112000	81	152130	169
000176	193, 200, 204, 206, 214, 218, 223	066500	177	112010	81	152140	169
001586	204, 214, 223	067000	175	112020	81	152150	169
001596	204, 214, 223	067500	175	112030	81	152160	169
001606	194	067600	176	112110	217	152170	169
001616	195, 199	067610	176	112120	217	152180	169
001626	16, 17, 18, 20, 23	079010	218	112130	217	152190	169
001656	175	079020	206	112140	217	152200	169
001696	203, 212, 214, 215, 222	079040	200, 218	112170	217	152500	52, 62
001706	175	080026	209	112720	217	152510	52, 62
001716	203, 212, 214, 215, 222	080046	209	113000	82	152520	52, 62
001726	205, 215, 264	087020	206	113020	47	152600	63
001746	171	087030	224	113030	47	152610	63
001766	211	087040	199, 216	114000	81	152620	63
001776	136	087050	206	114010	81	153000	170
001786	280	088010	218	114020	81	153010	170
001796	280	094016	214	115000	46	153020	170
001806	280	094026	214	115010	46	153030	170
001816	284	094036	204	115020	46	153040	170
001826	285	094046	204	115030	47	153050	170
001830	253	094056	223	115040	47	153060	170
001846	167	094066	223	116000	82	153070	170
001872	253	102200	205, 264	116010	82	153120	169
001916	215	104090	210	116020	82	153130	170
001940	204, 214, 223	104100	210	116030	82	153200	29
002010	210	104130	203	116040	82	153210	29
002011	210	104140	203	116050	82	153220	29
014580	264	104170	222	116060	82	153230	29
016600	190	104180	222	116600	190	153240	29
025100	187	104210	210	117000	198	153250	29
025110	187	104220	210	117010	198	153260	29
025200	187	104250	210	117700	195	153270	14, 43
025210	187	104260	210	118000	195	153280	14, 43
025300	187	104290	202	118440	195	153660	171
025310	187	104300	202	119400	195	153670	171
035000	186	104310	202	119410	195	153700	171
035300	186	104330	222	119450	199	153710	171
038000	183	104340	222	119470	199	153860	78
040000	178	104360	222	119500	194	153870	78
040500	178	104450	202	119510	194	153880	78
052000	169	104510	202	119550	199	153890	78
052500	169	104520	203	119920	194	155020	164
053700	171	104570	202	119930	194	155080	165
053710	171	104640	210	120000	198	155090	165
055020	160	104650	210	125100	187	155100	160
055030	160	104670	210	125200	187	155110	160
056000	163	104680	222	125300	187	155120	160
056010	163	104690	203	125310	187	155130	160
056020	165	104700	210	125350	187	155140	160
056030	165	104730	210	125430	187	155150	160
056500	164	104740	210	135200	186	155450	162
056510	163	107000	197	135300	186	155460	162
056540	165	107010	197	138000	183	155470	162
056550	165	107040	197	141000	178	155480	162
056700	167	107050	197	141500	178	155490	162
056710	167	107500	197	141640	9	155500	162
056720	168	107510	197	142500	19	155520	165
056730	168	109010	198	151236	285	155540	162
058000	158	110520	194	152000	58, 63	155550	164
059000	159	110530	194	152010	58	155560	164
059500	157	110550	194	152020	52, 58, 62	155570	161
060000	154	110560	194	152030	58	155580	161
		111000	197	152040	58	156040	166
		111010	197	152050	58	156050	166
		111020	197	152060	58	156060	166

Par référence - By part number - nach Artikelnummer

156070	166	166100	177	177136	275	194270	223
156130	166	166500	15, 19	177226	275	194310	223
156150	166	166600	177	178340	199	195000	22
156200	163	166700	35	179210	218	195010	208
156210	163	167000	173	179220	206	195030	208
156220	163	167001	70	179240	200, 218	195060	225
156250	168	167100	173	179310	218	196010	193
156260	168	167150	15, 19, 20	179320	206	196020	193
156290	163	167500	173	179340	200, 218	196170	193
156300	163	167530	176	179350	218	197040	63
156310	163	167550	176	180010	209	197050	63
156340	165	167600	173	180030	209	197070	17, 23
156350	165	167630	10	180040	209	197080	17, 23
156380	168	167640	10	180050	209	198010	213
156390	168	168010	10	180220	209	198020	213
156540	163	168020	10	180240	209	198030	213
156550	163	168090	173	181000	216	198040	204
156590	165	168100	173	181050	200	198050	204
156600	165	168140	53	181070	200	198060	223
156630	166	168220	48, 53, 73	182020	205	198510	211
156640	166	168260	48, 53, 73	185010	208	198520	211
156770	164	168270	173	185020	208	198530	211
156780	164	168340	173	185030	225	198540	211
156790	164	168350	76	185040	198	198580	211
156860	38	168360	76	185050	225	198620	211
156870	38	168370	76	185160	198	198640	222
158030	158	168380	76	186030	208	198650	211
158040	158	168390	9	186040	208	198660	203
158050	158	168480	174	187120	206	198690	203
159010	159	168490	35	187130	224	198740	211
159020	159	168590	174	187140	199, 216	198760	211
159030	159	168600	174	187150	206	207000	82, 85
159500	157	168610	174	187720	206	207010	82, 85
159510	157	168770	176	187730	224	207020	82, 85
159520	157	168780	176	187760	199, 216	240346	259
159530	157	168790	176	187770	206	240356	259
160000	154	168800	176	188010	217	240366	259
160020	154	168830	176	188110	217	241346	259
160030	154	168890	10	188210	217	241356	259
160060	154	169000	49, 53, 59	188310	217	241366	259
160070	154	169010	49, 53, 59	188610	217	273026	282
160080	156	169020	49, 53	188710	217	280009	280
160090	156	169030	49, 53	191100	24	280019	280
160100	156	169060	48, 52	191110	24	280029	280
160110	156	169070	48, 52	191120	24	280039	280
160120	156	169160	174	191140	24	280049	278
160130	156	169170	174	191150	24	280059	280
160140	156	169180	174	191170	24, 60	280069	280
160150	156	169190	174	193020	215	280089	280
160200	155	169280	174	193170	215	280099	280
160230	155	169310	49, 54	193200	205	280109	280
160240	155	169320	49, 54	193280	215	280129	280
160270	155	169330	49, 54	193290	215	280139	280
161000	153	169380	10	193360	215	280149	280
161010	153	169390	175	194010	213	465219	261
161200	153	169400	175	194020	213	465229	261
161210	153	169410	175	194030	213	465239	261
164000	185	169420	175	194070	213	465319	261
164010	185	175020	275	194080	213	465329	261
164020	185	175076	275	194090	213	465339	261
164030	185	175086	275	194130	204	465419	261
165020	185, 234	175096	275	194140	204	465429	261
165030	185, 234	175106	283	194150	204	465439	261
165040	185, 234	175116	283	194190	204	465519	261
165050	185, 234	176000	191	194250	223	465529	261
166000	177	176050	191	194260	223	500930	183

500940	183	67513371	179	D10493	212	D12112	240
521010	207	67513380	179	D10494	212	D12263	240
521050	207	67513390	179	D10495	212	D12334	182
610050	196	A10060	270	D10496	212	D12335	182
610080	221	A10061	270	D10497	212	D12336	182
610091	192	A10062	271	D10498	212	D12337	182
611010	221	A10064	270	D10499	222	D12338	33
611020	221	A10065	271	D10500	203	D12339	33
611070	269	A10066	271	D10502	193	D12340	33
611080	269	A10091	256	D10503	221	D12341	33
611090	275	A10537	124	D10504	283	D12390	241
611110	269	A10779	284	D10505	282	D12428	219
611140	269	A10911	99	D10508	282	D12429	219
611150	269	A11105	93	D10510	282	D12430	219
611410	270	A11212	273	D10513	279	D12449	278
611500	268	A11316	112	D10514	279	D12450	278
611510	268	A11317	112	D10515	279	D12471	219
611520	268	A11440	99, 117	D10517	284	D12472	219
611530	268	A11670	94	D10518	284	D12473	219
611540	268	A11702	94	D10519	284	D12488	240
611550	268	A11706	104	D10520	284	D12699	210
611560	271	A11814	93	D10597	271	D12711	219
611570	270	A11818	93	D10642	221	D12712	219
611580	268	A11826	104	D10643	221	D12713	261
611590	268	A11832	92	D10800	221	D12714	261
624016	259	A11838	93	D10839	191	D12715	261
624026	259	A11841	93	D10840	191	D12867	212
624036	259	A11844	93	D10841	190	D12953	159, 175, 253
630100	253	A11848	93	D10873	268	D13019	240
630110	253	A11961	94	D10874	268	D13020	240
630120	253	A11962	94	D10900	260	D13034	219
672410	216	A12052	98	D10901	260	D13035	219
725000	180	A12071	124, 125	D11147	221, 284	D13205	261
725002	181	A12146	97, 117	D11256	260	D13206	261
725010	180	A12354	104	D11259	260	D13207	261
725012	181	A12434	125	D11261	260	D13234	275
725020	180	A12435	124	D11262	260	D13235	275
725022	181	A12483	125	D11263	260	D13237	275
725032	181	A12486	94	D11264	260	D13248	275
725040	180	A12546	117	D11268	202, 284	D13249	282
726290	181	A12601	123	D11399	203	D13250	282
726300	181	A12613	124, 125	D11400	222	D13251	285
726310	180	A12617	124, 125	D11479	182	D13254	283
726320	180	A12623	124	D11480	182	D13255	283
726350	181	A12631	125	D11481	182	D13256	283
726450	181	A12657	141	D11482	182	D13257	283
726460	181	A12659	141	D11487	270	D13260	282
01442621	201, 207, 224	A12720	98	D11578	270	D13262	279
		A13086	148	D11626	278	D13263	282
01447801	207	A13087	148	D11627	278	D13277	221
01487801	201	A13152	148	D11628	278	D13288	171
01497801	224	A13472	113	D11689	278	D13295	281
02070603	224	A13473	113	D11796	221	D13494	256
02070605	200	A13538	112	D11797	221	D13497	258
02070637	207	A13816	94, 113	D11865	279	D13501	258
02077003	224	A13888	272	D11868	276	D13502	275
02077011	207	A14090	99	D11888	193	D13609	192
4330012	284	A14101	99	D11889	275	D13610	192
9115118	285	A14102	99	D11899	221	D13616	257
10850603	196	A14103	99	D11955	262	D13617	258
10850605	196	A14106	99	D11956	262	D13618	258
40300117	191	A14109	98	D11957	262	D13619	258
40300225	191	A14127	99	D11958	262	D13620	258
60760541	179	A14420	184	D12020	262	D13621	258
60760551	179	D10132	202, 222, 284	D12021	262	D13622	258
67513361	179	D10227	193	D12111	240	D13624	221

D13710	203	D14312	269	D14465	247	D14542	236
D13713	212	D14313	269	D14466	247	D14543	236
D13725	278	D14314	269	D14467	247	D14544	236
D13726	278	D14315	270	D14468	247	D14545	236
D13807	253	D14316	269	D14469	247	D14546	236
D13808	253	D14320	229	D14470	247	D14547	237
D13810	253	D14321	229	D14471	247	D14548	237
D13816	189	D14322	229	D14472	250	D14549	237
D13817	179	D14323	229	D14473	250	D14550	237
D13860	252	D14324	228	D14474	250	D14551	237
D13862	252	D14325	228	D14475	248	D14552	237
D13863	252	D14326	255	D14476	248	D14553	237
D13874	192	D14327	258	D14477	248	D14554	243
D13875	220	D14328	254	D14478	248	D14555	238
D13876	276	D14329	257	D14479	248	D14556	238
D13877	276	D14345	189	D14480	248	D14557	238
D13878	276	D14348	189	D14481	249	D14558	238
D13879	276	D14352	277	D14482	244	D14562	239
D13880	277	D14353	252	D14483	244	D14563	239
D13881	258	D14354	252	D14484	244	D14564	259
D13887	258	D14357	243	D14485	244	D14565	251
D13889	270	D14358	243	D14486	244	D14566	251
D14030	220	D14359	188	D14487	245	D14567	263
D14031	220	D14360	188	D14488	245	D14568	263
D14034	220	D14380	37	D14489	245	D14569	263
D14035	220	D14381	37	D14490	245	D14574	269
D14037	219	D14385	231	D14491	245	D14575	269
D14038	219	D14386	233	D14492	245	D14576	271
D14063	255	D14387	234	D14493	245	D14577	270
D14113	264	D14421	220	D14494	245	D14578	270
D14114	264	D14422	220	D14495	245	D14587	259
D14116	192	D14423	220	D14496	245	D14588	259
D14124	258	D14424	220	D14500	244	D14589	259
D14148	258	D14425	220	D14501	244	D14590	259
D14156	240	D14426	220	D14502	244	D14591	259
D14157	241	D14427	220	D14503	244	D14592	259
D14158	241	D14428	220	D14504	250	D14593	259
D14159	241	D14429	220	D14505	250	D14594	259
D14160	232	D14430	220	D14506	250	D14595	259
D14161	232	D14431	220	D14507	245	D14596	259
D14162	232	D14432	220	D14508	245	D14598	263
D14163	234	D14434	277	D14509	245	R12486	277
D14164	242	D14435	277	D14510	245	R12499	279
D14165	242	D14436	277	D14511	251	R12575	278
D14166	242	D14437	277	D14512	251	R12576	278
D14167	242	D14444	231	D14513	251	R12931	171
D14168	231	D14445	231	D14514	251	R12934	171
D14169	230	D14446	233	D14515	251	R13195	278
D14170	277	D14447	232	D14516	251	R13676	125
D14188	189	D14448	233	D14517	192	R14171	281
D14189	189	D14449	246	D14518	190	R14172	281
D14190	252	D14450	246	D14523	188	R14173	281
D14191	239	D14451	246	D14524	188	R14364	192
D14192	239	D14452	246	D14525	188	R14407	279
D14196	254	D14453	246	D14526	188	R14412	284
D14208	277	D14454	249	D14527	190	R14413	230
D14210	253	D14455	249	D14532	260	R14416	284
D14211	253	D14456	249	D14533	260	R14338	184
D14214	276	D14457	249	D14534	260	R14339	184
D14216	255	D14458	248	D14535	260		
D14236	255	D14459	248	D14536	260		
D14249	243	D14460	248	D14537	265		
D14250	243	D14461	248	D14538	265		
D14288	231	D14462	247	D14539	265		
D14295	232	D14463	247	D14540	235		
D14311	271	D14464	247	D14541	235		

E2	78	FM76	191
E2	109	207	200
E2	111	207	200
E2	112	207	200
E2	113	C166	190
E2	121	FE85	225
E2	136	FM76	191
E2	146	LA25	187
E2	193	FE81	216
E2	219	207	200
E2	219	0207	224
E2	314	FE80	209
E2	462	LA25	187
E2	521	LA25	187
E2	530	C166	190
E2	621	C166	190
E13	697	FRR	191
E13	698	FRR	191
E2	727	207	200
E2	781	FE80	209
E2	864	LA38	183
E2	896	FE87	216
E2	915	FE80	209
E2	1051	LA38	183
E2	1052	LA38	183
E9	1226	FRC	188
E9	1288	FRR	189
E2	1295	SMD00	211
E2	2040	LC8	161
E2	2065	SMD98	203
E2	2785	FE79	200
E2	3703	FE79	200
E2	3704	FE79	200
E4	4052	FRR	191
E2	4054	FPL93	215
E2	4088	FE98	204
E2	4089	FE98	204
E2	4090	FE94	204
E2	4091	FE94	204
E2	4092	FE94	204
E2	4093	FE98	204
E11	4249	BX868	192
E2	4701	FE87	216
E2	4702	FE79	200
E2	4703	FE87	216
E2	5040	C194	195
E2	5047	ICDL94	199
E2	5052	FE95	208
E2	5060	1085	196
E2	5117	C195	194
E2	5126	FE95	208
E11	6219	BX816	196
E9	6653	FRR	189
E2	7001	EPP96	193
E2	7001	EPP98	193
E2	7102	FE02	205
E2	7139	ICDL94	199
E2	8003	FM97	24
E2	8004	FM97	24
E2	8005	LC5	169
E2	8034	FM97	24
E2	8035	FM97	24
E2	8040	SMD98	203
E12	8434	725	182
E13	8434	725	182
E2	9014	FM97	24
E2	9025	ICDL15	198
E2	9033	FE85	225
E2	9036	FE85	225
E2	9037	FE85	225
E2	9056	LC7T	176
E13	9657	FRR	191
E2	10035	DX	221
E2	10073	SRD08	197
E2	10113	LC9 LED	158
E11	10532	DX	221
E4	10532	DX	221
E13	10989	BX868	192
E2	11017	EPP96LED	192
E2	11128	ICDL10	198
E9	11542	FRC	188
E9	11734	SLIM	179
E2	12007	LC9	159
E2	12056	C105	194
E2	12164	LC10 LED	157
E2	12165	LC10 LED	157
E2	12166	LC10 LED	157
E2	12167	LC10 LED	157
E2	12168	LC10 LED	157
E4	13992	FRR	191
E2	14010	DX	221
E2	14085	LC11	154
E2	14086	LC11	154
E2	16005	CTL15	185
E2	16007	BL15	185
E2	16027	LC12T	153
E1	21633	PLR272	207
E4	23271	FRR	191
E3	38553	2711	188
E3	47364	725	182
E3	52308	725	182
E3	52309	725	182
E3	52310	725	182
E3	52312	725	182
E2	86708	FE85	225
E2	86710	FE87	216
E2	86711	FE87	216
E2	87002	1085	196
E2	87072	144	207
E2	87078	148	201
E2	87712	C184	195
E2	87714	FE86	208
E2	88017	LC7	173
E2	88033	LC6	177
E2	88034	LC6	177
E2	88035	LC7	173
E2	88042	FG82	205
E2	88714	FE88	217
E2	90711	FE81	216
E2	90724	LA35	186
E2	91098	LC4	178
E2	91099	LC4	178
E2	91714	C177	195
E2	92004	LA25	187
E2	92025	4030	191
E2	92057	FM91	24
E2	92058	FM91	24
E2	92059	FM91	24
E2	92060	FM91	24



Feux arrière - Rear lamps - Heckleuchten





Feux clignotants - Flasher lamps - Fahrtrichtungsanzeiger



Feux de position - Position lamps - Positionsleuchten





Produits complémentaires - Complementary products - Ergänzende Produkte





MISE EN GARDE SUR LES RISQUES JURIDIQUES DE LA CONTREFAÇON
WARNING ON LEGAL RISKS OF ORIGINAL PARTS COPIES / FORGERY
HINWEIS AUF DIE RECHTLICHEN RISIKEN BEI FÜR VERWENDUNG

MISE EN GARDE SUR LES RISQUES JURIDIQUES DE LA CONTREFAÇON DES PIÈCES D'ORIGINE

Les **remplacements** ou **modifications** de composants autres que ceux montés et recommandés par le constructeur peuvent remettre en cause la sécurité des usagers de la route (diminution des performances photométriques).

Ex : **Le montage d'un cabochon adaptable sur un feu d'origine Vignal est interdit.**

Toute opération de ce type sur le matériel sera à **la charge entière de celui qui sera intervenu** et pourra **remettre en cause** l'homologation du véhicule délivrée par les autorités compétentes.
 Le fabricant dégage sa responsabilité réglementaire.

La contrefaçon et la concurrence déloyale de pièces sont condamnées par la loi civile et pénale :

- La contrefaçon engage la responsabilité civile et pénale du fabricant, du revendeur, voire dans certains cas de l'utilisateur des pièces de contrefaçon.
- La concurrence déloyale engage la responsabilité civile du fabricant et du revendeur de copies serviles; en tirant de cette opération un avantage injustifié, **il fausse les règles normales de la concurrence** et réalise de ce fait **un acte de parasitisme** en détournant le travail de recherche et de conception, ainsi que le savoir-faire des constructeurs.

WARNING ON LEGAL RISKS OF ORIGINAL PARTS COPIES / FORGERY

The **replacements** or **modifications** of components other than those assembled and recommended by the manufacturer can reduce the safety of the road users (reduction in the photometric performances).

Ex : **The assembly of an adaptable lens on an original lamp Vignal is prohibited.**

Any operation of this type on the material **will be judged as responsibility of who intervened** and will **compromise the homologation of the vehicle** delivered by the authorities.
 The manufacturer declines all responsibilities.

The forgery and the unfair competition of original parts are condemned by the civil and penal law :

- The forgery engages the civil and penal liability of the manufacturer and the retailer, even in certain cases of the user of the forgery parts.
- The unfair competition engages the civil liability of the manufacturer and the retailer of forged parts; by taking an unjustified advantage from this operation, the forgery **distorts the normal rules** of competition and carries out an **act of parasitism** by diverting the design and R&D task, as well as know-how of the manufacturers.

HINWEIS AUF DIE RECHTLICHEN RISIKEN BEI FÜR VERWENDUNG VON NACHBAUTEILEN ANSTELLE VON ORIGINALERSATZTEILEN

Der **Austausch** oder die **Modifikation** von Teilen, die nicht in der Erstausrüstung montiert und vom Hersteller empfohlen wurden, können die Sicherheit der Verkehrsteilnehmer beeinträchtigen (Verringerung der lichttechnischen Leistung).

Beispiel: **Die Verwendung einer nachgebauten Lichtscheibe auf einer VIGNAL-Heckleuchte ist nicht zulässig.**

Jede Verwendung dieses Materials wird **zu Lasten des Verwenders** ausgelegt und kann die **Zulassung des Fahrzeugs durch die Zulassungsstellen in Frage stellen**.
 Der Fahrzeughersteller entzieht die gesetzliche Gewährleistungspflicht.

Die Fälschung (Nachbau) von Originalteilen und der unlautere Wettbewerb werden durch das Zivil- und Strafrecht verurteilt:

- Die Fälschung (Nachbau) von Originalteilen zieht die zivil- und strafrechtliche Haftung des Herstellers, des Wiederverkäufers und in bestimmten Fällen auch des Benutzers nach sich.
- Der unlautere Wettbewerb zieht **die zivilrechtliche Haftung des Herstellers und des Wiederverkäufers von Nachbauteilen nach sich**; sie ziehen aus dieser Operation einen ungerechtfertigten Nutzen, und verfälschen die normalen Regeln des Wettbewerbs, indem sie die Forschungs- und Konzeptionsarbeit sowie das Know-How der Konstrukteure nutzen.

NORMES ET RÉGLEMENTATION
STANDARDS AND REGULATIONS
NORM UND REGLEMENTIERUNG

Les extraits de réglementation sont disponibles sur notre site web.

Les éléments sont extraits du règlement ECE R48 concernant la majorité des véhicules.
 Se référer au règlement pour des configurations particulières.

Les produits doivent être homologués selon le dernier amendement en vigueur
 L'utilisateur est responsable de la conformité de l'équipement de son véhicule.

VIGNAL SYSTEMS s'engage sur la conformité de ses produits.

 Le sigle ADR signifie que le produit est homologué pour le montage sur des véhicules qui satisfont aux dispositions ADR (accord européen relatif au transport international des marchandises dangereuses par route).
 Les produits ADR ont un indice de protection d'au moins IP54.
 L'indice de protection IP détermine le degré de protection du matériel contre la pénétration des corps solides (1er chiffre) et des liquides (2ème chiffre).

Exemple : IP54 
 1er chiffre : 5 => Protégé contre les infiltrations de poussière
 2ème chiffre : 4 => Protégé contre les projections d'eau (haute pression) de toutes les directions

The regulation extracts are available on our website.

The elements are extracts from the ECE R48 regulation which concern most of the vehicles.
 Please refer to the regulation for any special configuration.

The products must be homologated according to the last amendments in force.
 The user is responsible for the conformity of its vehicle's equipment.

VIGNAL SYSTEMS is committed to the conformity of its products

 The ADR sign means the product is homologated on vehicles which are under ADR regulations (European Agreement concerning the International Carriage of Dangerous Goods by Road).
 The ADR products have an ingress protection rating of at least IP54.
 IP Code classifies and rates the degrees of protection provided against the intrusion of solid objects (1st number) and water (2d number)

Exemple : IP54 
 1st number : 5 => Protected against dust
 2d number : 4 => Protected against splashing water from all directions

Auszüge aus der Reglementierung sind auf unserer Webseite ersichtlich.

Es handelt sich um die für die meisten Fahrzeuge zutreffenden Auszüge der Reglementierung ECE R48.
 Für Sonderfälle sehen Sie bitte die komplette Reglementierung ein.

Die Produkte sind nach dem aktuellstem Änderungsstand zu homologieren.
 Der Fahrzeugführer ist für die zulässige Ausrüstung seines Fahrzeuges verantwortlich.

VIGNAL SYSTEMS garantiert die Konformität der Produkte.

 Das ADR Zeichen bedeutet, dass das Produkt für den Einbau in Fahrzeuge mit ADR Zulassung (Europäisches Übereinkommen über die internationale Beförderung gefährlicher Güter auf der Straße) geeignet ist. ADR-Produkte haben einen Schutzfaktor von mindestens IP54.
 Der IP Schutzfaktor bestimmt den Schutzgrad eines Bauteils gegenüber das Eindringen von festen Körpern (erste Ziffer) und von Flüssigkeiten (zweite Ziffer).

Beispiel : IP 54 
 Erste Ziffer : 5 => Schutz gegen das eindringen von Staub
 Zweite Ziffer : 4 => Schutz gegen Spritzwasser aus allen Richtungen

NORMES ET RÉGLEMENTATION
STANDARDS AND REGULATIONS
NORM UND REGLEMENTIERUNG

Indice de protection

Indice	1 ^{er} chiffre (dizaine) = Protection contre la poussière	2 ^{ème} chiffre (unité) = Protection contre l'eau
0	Aucune protection.	Aucune protection.
1	Protégé contre les corps solides supérieurs à 50 mm.	Protégé contre les chutes verticales de gouttes d'eau.
2	Protégé contre les corps solides supérieurs à 12,5 mm.	Protégé contre les chutes de gouttes d'eau jusqu'à 15° de la verticale.
3	Protégé contre les corps solides supérieurs à 2,5 mm.	Protégé contre l'eau en pluie jusqu'à 60° de la verticale.
4	Protégé contre les corps solides supérieurs à 1 mm.	Protégé contre les projections d'eau de toutes directions.
5	Protégé contre les poussières.	Protégé contre les jets d'eau de toutes directions à la lance.
6	Totalement protégé contre les poussières.	Protégé contre les forts jets d'eau de toutes directions à la lance.
7	-	Protégé contre les effets de l'immersion (jusqu'à 1 m).
8	-	Matériel submersible dans des conditions spécifiées (immersion prolongée) au delà de 1 m et pendant 30 minutes.
9K	-	Matériel submersible dans des conditions spécifiées (immersion prolongée) au delà de 1 m et protection contre le nettoyage à haute pression.

International Protection

Level	1 st digit = Solid particles protection	2 nd digit = Liquid ingress protection
0	Not protected.	Not protected.
1	Protected against solid objects superior to 50 mm.	Protected against vertical dripping.
2	Protected against solid objects superior to 12,5 mm.	Protected against dripping (inclined 15°).
3	Protected against solid objects superior to 2,5 mm.	Protected against spraying water.
4	Protected against solid objects superior to 1 mm.	Protected against splashing of water from any direction.
5	Dust protected.	Protected against water jets by a nozzle.
6	Dust tight.	Protected against powerful water jets by a nozzle.
7	-	Protected against immersion up to 1 m.
8	-	Submersible equipment under specified conditions beyond 1 m for 30 minutes.
9K	-	Protected against close-range high pressure, high temperature spray downs.

Schutzart

Kennziffer	Erste Kennziffer = Schutz gegen Fremdkörper	Zweite Kennziffer = Bedeutung: Schutz gegen Wasser
0	kein Schutz.	kein Schutz.
1	Geschützt gegen feste Fremdkörper mit Durchmesser ab 50 mm.	Schutz gegen Tropfwasser.
2	Geschützt gegen feste Fremdkörper mit Durchmesser ab 12,5 mm.	Schutz gegen fallendes Tropfwasser, wenn das Gehäuse bis zu 15° geneigt ist.
3	Geschützt gegen feste Fremdkörper mit Durchmesser ab 2,5 mm.	Schutz gegen fallendes Sprühwasser bis 60° gegen die Senkrechte.
4	Geschützt gegen feste Fremdkörper mit Durchmesser ab 1,0 mm.	Schutz gegen allseitiges Spritzwasser.
5	Geschützt gegen Staub in schädigender Menge.	Schutz gegen Strahlwasser (Düse) aus beliebigem Winkel.
6	Staubdicht.	Schutz gegen starkes Strahlwasser.
7	-	Schutz gegen zeitweiliges Untertauchen.
8	-	Schutz gegen dauerndes Untertauchen.
9K	-	Schutz gegen Wasser bei Hochdruck-/Dampfstrahlreinigung, spezifisch für Straßenfahrzeuge.



2017

VIGNAL LIGHTING GROUP

19, avenue du 24 Août 1944
CS 54012
69964 CORBAS cedex
France

Tel : +33(0)4 72 90 29 29
Fax : +33(0)4 72 90 29 01
mail : info@vignal-systems.com

www.vignal-systems.com
www.vignal-lighting-group.com

